

REQUEST FOR QUOTATIONS

Transnet Freight Rail a Division of Transnet SOC Ltd. invites all interested parties to respond to a request for quotation (RFQ) as indicated below. All RFQ's should be submitted on the appropriate tender forms and should be deposited in the Tender Box before 10h00 on the closing date of the RFQ/s.

If delivered by hand, the RFQ submissions must be addressed to The Chairman of the Acquisition Council, Queens Warehouse, Ground Floor Reception, 237 Mahatma Gandhi Road Point, Durban

RFQ documents may be obtained **Free Of Charge** on and after Tuesday **13th May 2014** and must be collected before 15h00 on Monday 19 May 2014 at Transnet Freight Rail, Supply Chain Services, Queen's Warehouse, 237 Mahatma Gandhi Road, Durban during the office hours **09h00 to 15h00** during weekdays. (NB: No tenders will be issued after this deadline)

RFQ documents may be viewed from the website by clicking on the RFQ number that is highlighted in red on the website: (<http://www.transnetfreightrail-tfr.net/SupplierPages/Tenders.aspx>)

RFQ NUMBER: RME DBN 025/2014

DESCRIPTION: SUPPLY AND DELIVERY OF BOLTS AND NUTS

REQUIRED AT: 130 EEL ROAD BAYHEAD DURBAN

A Formal briefing session **will not be held** but should Respondents have specific queries they should e-mail these to the Transnet employee(s) indicated in the (RFQ)

CLOSING DATE: 29 MAY 2014 @ 12H00.

For enquiries regarding the collection of the RFQ please contact:

Name: Anne Mongie

Tel : 031 361 1759

Email: anne.mongie@transnet.net

Transnet Freight Rail urges Clients & Suppliers to report fraud/corruption at Transnet to TIPOFFS
ANONYMOUS: 0800 003 056

Transnet Freight Rail, a division of

TRANSNET SOC LTD

Registration Number 1990/000900/30

[hereinafter referred to as **Transnet**]

REQUEST FOR QUOTATION [RFQ] No RME DBN- 025/2014

FOR THE SUPPLY OF: BOLTS AND NUTS

FOR DELIVERY TO: 130 EEL ROAD BAYHEAD DURBAN

ISSUE DATE: 13 MAY 2014

CLOSING DATE: 29 MAY 2014

CLOSING TIME: 12:00

"PREVIEW COPY ONLY"

Section 1 NOTICE TO BIDDERS

Quotations which must be completed as indicated in Section 2 of this RFQ are to be submitted as follows:

METHOD: Tender Box
CLOSING VENUE: Queens Warehouse Ground Floor Reception
 237 Mahatma Gandhi Road
 Point, Durban

1 Responses to RFQ

Responses to this RFQ [**Quotations**] must not include documents or reference relating to any other quotation or proposal. Any additional conditions must be embodied in an accompanying letter.

2 Broad-Based Black Economic Empowerment [B-BBEE]

Transnet fully endorses and supports the Government's Broad-Based Black Economic Empowerment Programme and it would therefore prefer to do business with local business enterprises who share these same values. Transnet will accordingly allow a "preference" to companies who provide a valid B-BBEE Verification Certificate. All procurement transactions will be evaluated accordingly.

2.1 B-BBEE Scorecard and Rating

As prescribed in terms of the Preferential Procurement Policy Framework Act (PPPFA), Act 5 of 2000 and its Regulations, Respondents are to note the following:

- Proposals will be evaluated on price which will be allocated 80 or 90 points and preference which will be allocated 20 or 10 points, dependent on the value of the Goods .
- The 80/20 preference point system applies where the acquisition of the Goods will be less than R1 000 000.00. However, if the 80/20 preference point system is stipulated in this RFQ and all Bids received exceed R1 000 000.00, the RFQ will be cancelled.
- The 90/10 preference point system applies where acquisition of the Goods will exceed R1 000 000.00. However, if the 90/10 preference point system is stipulated in this RFQ and all Bids received are equal to or below R1 000 000.00, the RFQ will be cancelled.
- In this RFQ, Transnet will apply **90/10** preference point system prescribed in the PPPFA.

In compliance with the Government Gazette No 34612, Notice No. 754 dated 23 September 2011, as from 1 October 2011 valid B-BBEE Verification Certificates must be issued by:

- (i) Verification Agencies accredited by the South African National Accreditation System [SANAS]; or
- (ii) Registered Auditors approved by the Independent Regulatory Board of Auditors [IRBA], in accordance with the approval granted by the Department of Trade and Industry.

Enterprises will be rated by such agencies based on the following:

a) Large Enterprises [i.e. annual turnover greater than R35 million]:

- Rating level based on all seven elements of the B-BBEE scorecard

b) Qualifying Small Enterprises – QSE [i.e. annual turnover between R5 million and R35 million]:

- Rating based on any four of the elements of the B-BBEE scorecard

c) Exempted Micro Enterprises – EME [i.e. annual turnover less than R5 million]:

In accordance with B-BBEE Codes of Good Practice [Statement 000, Section 4], any enterprise with an annual total revenue of R 5 million or less qualifies as an EME.

- Automatic rating of B-BBEE Level 4 irrespective of race or ownership
- Black ownership greater than 50% or Black Women ownership greater than 50% automatically qualify as B-BBEE Level 3

Sufficient evidence to qualify as an EME would be a certificate (which may be in the form of a letter) from an auditor or accounting officer or a certificate from a Verification Agency accredited by SANAS. The certificate must confirm the company's turnover, black ownership / black female ownership, B-BBEE status level and validity date.

Respondents are required to furnish proof of the above to Transnet. [i.e. a valid detailed scorecard as stipulated above in respect of Large Enterprises and QSEs, or a valid certificate in respect of EMEs].

Transnet will accordingly allocate a maximum of **10 [ten] points** to the Respondent's final score based on an entity's B-BBEE scorecard rating. [Refer **Annexure A- B-BBEE Preference Points Claim Form** for further details.]

N.B. Failure to submit a B-BBEE certificate, which is valid as at the Closing Date of this RFP, will result in a score of zero being allocated for B-BBEE.

[Refer clause Error! Reference source not found. below for Returnable Documents required]

B-BBEE Improvement Plan – Not Applicable**Supplier Development Initiatives - Not Applicable****3 Communication**

Respondents are warned that a response will be liable for disqualification should any attempt be made by a Respondent either directly or indirectly to canvass any officer(s) or employee of Transnet in respect of this RFQ between the closing date and the date of the award of the business.

A Respondent may, however, before the closing date and time, direct any written enquiries relating to the RFQ to the following Transnet employee:

Name: Anne Mongie
Email: anne.mongie@transnet.net

Respondents may also, at any time after the closing date of the RFQ, communicate with Boitumelo Manyakalle Regional Procurement Manager on any matter relating to its RFQ response:

Telephone 031 361 1016
Email Boitumelo.manyakalle@transnet.net

4 Tax Clearance

The Respondent's original valid Tax Clearance Certificate must accompany the Quotation. Failure to provide this document with the RFQ submission will result in disqualification.

5 VAT Registration

The valid VAT registration number must be stated here: _____ *[if applicable]*.

6 Legal Compliance

The successful Respondent shall be in full and complete compliance with any and all applicable national and local laws and regulations.

7 Changes to Quotations

Changes by the Respondent to its submission will not be considered after the closing date and time.

8 Pricing

All prices must be quoted in South African Rand on a fixed price basis, excluding VAT.

9 Prices Subject to Confirmation

Prices quoted which are subject to confirmation will not be considered.

10 Negotiations

Transnet reserves the right to undertake post-tender negotiations with selected Respondents or any number of short-listed Respondents.

11 Binding Offer

Any Quotation furnished pursuant to this Request shall be deemed to be an offer. Any exceptions to this statement must be clearly and specifically indicated.

12 Disclaimers

Transnet is not committed to any course of action as a result of its issuance of this RFQ and/or its receipt of a Quotation in response to it. Please note that Transnet reserves the right to:

- modify the RFQ's goods / service(s) and request Respondents to re-bid on any changes;
- reject any Quotation which does not conform to instructions and specifications which are detailed herein;
- disqualify Quotations submitted after the stated submission deadline;
- not necessarily accept the lowest priced Quotation;
- reject all Quotations, if it so decides;
- place an order in connection with this Quotation at any time after the RFQ's closing date;
- award only a portion of the proposed goods / service/s which are reflected in the scope of this RFQ;
- split the award of the order/s between more than one Supplier/Service Provider; or
- make no award at all.

In addition, Transnet reserves the right to exclude any Respondent from the bidding process who has been convicted of a serious breach of law during the preceding 5 [five] years, including but not limited to breaches of the Competition Act 89 of 1998. Respondents are required to indicate below whether or not they have been found guilty of a serious breach of law during the past 5 [five] years:

I/We _____ do hereby certify that I/we **have/have not been** found guilty during the preceding 5 [five] years of a serious breach of law, including but not limited to a breach of the Competition Act, 89 of 1998, by a court of law, tribunal or other administrative body. The type of breach that the Respondent is required to disclose excludes relatively minor offences or misdemeanours, e.g. traffic offences.

Where found guilty of such a serious breach, please disclose:

NATURE OF BREACH:

DATE OF BREACH: _____

Furthermore, I/we acknowledge that Transnet SOC Ltd reserves the right to exclude any Respondent from the bidding process, should that person or entity have been found guilty of a serious breach of law, tribunal or regulatory obligation.

13 RESPONDENT'S SAMPLES - NOT APPLICABLE

14 EVALUATION CRITERIA - TRANSNET WILL UTILISE THE FOLLOWING CRITERIA [NOT NECESSARILY IN THIS ORDER] IN CHOOSING A SUPPLIER/SERVICE PROVIDER, IF SO REQUIRED:

- **Administrative responsiveness** - Completeness of response and returnable documents
 - Pricing and price basis [firm] - whilst not the sole factor for consideration, competitive pricing and overall level of unconditional discounts¹ will be critical
 - B-BEE status of company

Preference points will be awarded to a bidder for attaining the B-BBEE status level of contribution in accordance with the table below:

¹ Only unconditional discounts will be taken into account during evaluation. A discount which has been offered conditionally will, despite not being taken into account for evaluation purposes, be implemented when payment is effected.

B-BBEE Status Level of Contributor	Number of points (90/10 system)	
1	10	
2	9	
3	8	
4	5	
5	4	
6	3	
7	2	
8	1	
Non-compliant contributor	0	

15 Validity Period

Transnet desires a validity period of 90 [ninety] days from the closing date of this RFQ.

This RFQ is valid until _____

16 Banking Details

BANK: _____

BRANCH NAME / CODE: _____

ACCOUNT HOLDER: _____

ACCOUNT NUMBER: _____

17 Company Registration

Registration number of company / C.C. _____

Registered name of company / C.C. _____

18 Disclosure of Prices Quoted

Respondents must indicate here whether Transnet may disclose their quoted prices and conditions to other Respondents:

YES NO

19 Returnable Documents

Returnable Documents means all the documents, Sections and Annexures, as listed in the tables below.

- a) Respondents are required to submit with their Quotations the **mandatory Returnable Documents**, as detailed below.

Failure to provide all these Returnable Documents at the Closing Date and time of this RFQ may result in a Respondent's disqualification. Respondents are therefore urged to ensure that all these Documents are returned with their Quotations.

All Sections, as indicated in the footer of each page, must be signed, stamped and dated by the Respondent. Please confirm submission of these mandatory Returnable Documents by so indicating [Yes or No] in the table below:

Mandatory Returnable Documents	Submitted [Yes or No]
SECTION 2 : Quotation Form	
- Original valid Tax Clearance Certificate [Consortia / Joint Ventures must submit a separate Tax Clearance Certificate for each party]	

b) In addition to the requirements of section (a) above, Respondents are further required to submit with their Quotations the following **essential Returnable Documents** as detailed below.

Failure to provide all these Returnable Documents may result in a Respondent's disqualification. Respondents are therefore urged to ensure that all these documents are returned with their Quotations.

All Sections, as indicated in the footer of each page, must be signed, stamped and dated by the Respondent. Please confirm submission of these essential Returnable Documents by so indicating [Yes or No] in the table below:

Essential Returnable Documents	Submitted [Yes or No]
SECTION 1 : Notice to Bidders	
- Valid B-BBEE Verification Certificate [RSA Large Enterprises and QSEs] Note: failure to provide a valid B-BBEE Verification Certificate at the closing date and time of the tender will result in an automatic score of zero being allocated for B-BBEE scorecard	
- Valid B-BBEE certificate from auditor, accounting officer or SANAS accredited Verification Agency [RSA EMEs] Note: failure to provide a valid B-BBEE Verification Certificate at the closing date and time of the tender will result in an automatic score of zero being allocated for B-BBEE scorecard	
- In the case of Joint Ventures, a copy of the Joint Venture Agreement or written confirmation of the intention to enter into a Joint Venture Agreement	
- SECTION 3 : Standard Terms and Conditions of Contract for the Supply of Goods & Services to Transnet	
SECTION 4 : Vendor Application Form	
- Original cancelled cheque or bank verification of banking details	
- Certified copies of IDs of shareholder/directors/members [as applicable]	
- Certified copy of Certificate of Incorporation [CM29/CM9 name change]	
- Certified copy of share certificates [CK1/CK2 if C.C.]	
- Entity's letterhead	
- Certified copy of VAT Registration Certificate [RSA entities only]	
- Certified copy of valid Company Registration Certificate [if applicable]	
- A signed letter from Respondent's auditor or accountant confirming most recent annual turnover figures	
- Audited Financial Statements for previous 3 years	

Respondent's Signature

Date & Company Stamp

Section 2 QUOTATION FORM

I/We _____
hereby offer to supply the goods/services at the prices quoted in the Price Schedule below, in accordance with the conditions related thereto.

I/We agree to be bound by those terms and conditions in:

- the Standard Terms and Conditions for the Supply of Goods or Services to Transnet [Section 3 hereof]; and
- any other standard or special conditions mentioned and/or embodied in this Request for Quotation.

I/We accept that unless Transnet should otherwise decide and so inform me/us, this Quotation [and, if any, its covering letter and any subsequent exchange of correspondence], together with Transnet's acceptance thereof shall constitute a binding contract between Transnet and me/us.

I/We further agree that if, after I/we have been notified of the acceptance of my/our Quotation, I/we fail to deliver the said goods/service/s within the delivery lead-time quoted, Transnet may, without prejudice to any other legal remedy which it may have, cancel the order and recover from me/us any expenses incurred by Transnet in calling for Quotations and/or having to accept any less favourable offer.

Price Schedule

I/We quote as follows for the goods required, on a "delivered nominated destination" basis, excluding VAT:

Item No	Description of Goods /Services	Unit of Measure	Quantity	Unit Price (ZAR)	Total Price (ZAR)
1	AS PER ATTACHED BILL OF QUANTITIES				

Delivery lead-Time from date of purchase order : _____ [days/weeks]

Notes to Pricing:

- a) All Prices must be quoted in South African Rand, exclusive of VAT
- b) To facilitate like-for-like comparison bidders must submit pricing strictly in accordance with the attached Bill of Quantities and not use a different format. Deviation from this pricing schedule could result in a bid being disqualified.
- c) Please note that should you have offered a discounted price(s), Transnet will only consider such price discount(s) in the final evaluation stage if offered on an unconditional basis.

Respondent's Signature

Date & Company Stamp

Section 3

STANDARD TERMS AND CONDITIONS FOR THE SUPPLY OF GOODS OR SERVICES TO TRANSNET

A Supplier/Service Provider shall be obliged to adhere to the Standard Terms and Conditions for the Supply of Goods and Services to Transnet as expressed hereunder. Should the Respondent find any condition(s) unacceptable, it should indicate which condition(s) is/are unacceptable and offer an alternative(s). A Quotation submitted by a Respondent will be subjected to review and acceptance or rejection of its proposed contractual terms and conditions by Transnet's Legal Counsel, prior to consideration for an award of business.

1 SOLE AGREEMENT

Unless otherwise agreed in writing, these terms [**Terms** and each **Term**] and Transnet's purchase order(s) [**Order** or **Orders**] represent the only conditions upon which Transnet SOC Ltd [**Transnet**] procures goods [**the Goods**] or services [**the Services**] specified in the Order from the person to whom the Order is addressed [**the Supplier/Service Provider**]. Transnet does not accept any other conditions which the Supplier/Service Provider may specify, unless otherwise agreed to by Transnet in writing. In the event of any inconsistency between these Terms and any Order these Terms shall take precedence.

2 CONFORMITY WITH ORDER

Goods/Services shall conform strictly with the Order. The Supplier/Service Provider shall not vary the quantities specified and/or the specification, if any, stipulated in the Order, without the prior written consent of Transnet. The Supplier/Service Provider warrants that the Goods/Services shall be fit for their purpose and of satisfactory quality.

3 DELIVERY AND TITLE

3.1 The delivery dates and addresses are those in the Order. Time shall be of the essence in respect of the Supplier's/Service Provider's obligations under the Order.

3.2 The Supplier/Service Provider will not be excused for delay in delivery or performance except due to circumstances outside its control and then only subject to the Supplier/Service Provider having notified Transnet in writing on becoming aware of such circumstances. Transnet may terminate an Order, in whole or in part, without incurring any liability to the Supplier/Service Provider if such a delay becomes, in Transnet's absolute opinion, significant.

3.3 Risk of loss or damage to Goods shall pass to Transnet on delivery, and title shall pass to Transnet when payment to the Supplier for the Goods has been effected. If on delivery, the Goods/Services do not conform to the Order, Transnet may reject the Goods/Services and the Supplier/Service Provider shall promptly rectify any defects or in Transnet's opinion, supply appropriate replacement Goods/Services at the Supplier's/Service Provider's expense within the specified delivery times, without any liability due by Transnet. Goods shall be subject to such testing and/or inspection as Transnet may consider necessary

4 PRICE AND PAYMENT

4.1 Prices specified in an Order cannot be increased. Payment for the Goods/Services shall be made by Transnet against an original undisputed invoice(s) [a Tax Invoice], supporting documentation and

month-end statement from the Supplier/Service Provider. Tax Invoices plus supporting documentation shall be posted to the address shown in the Order.

- 4.2 Payment of the Supplier's/Service Provider's valid Tax Invoice(s) will be made by Transnet in the South African currency and on the terms stated in the Order, the standard payment terms being 30 [thirty] days from date of receipt by Transnet of a month-end statement, unless otherwise agreed to in writing. Transnet shall arrange for payment of such Tax Invoices and any pre-authorised additional expenses incurred, provided that the authorised expenses are supported by acceptable documentary proof of expenditure incurred [where this is available]. Any amounts due in terms of these Terms shall be paid to the Supplier/Service Provider, taking into account any deduction or set-off and bank charges.

5 PROPRIETARY RIGHTS LIABILITY

If any allegations should be made or any claim asserted against Transnet that ownership of, or any act or omission by Transnet in relation to Goods/Services or any written material provided to Transnet relating to any Goods/Services or pursuant to an Order being a violation or infringement of any third party's contractual, industrial, commercial or intellectual property rights including but not limited to any patent, registered design, design right, trade mark, copyright or service mark on any application thereof, the Supplier/Service Provider hereby indemnifies Transnet against and hold it harmless from any and all losses, liabilities, costs, claims, damages and expenses [including any legal fees] arising directly or indirectly from such allegation or claim provided that this indemnity shall not apply where the allegation or claim arises solely as a result of the Supplier/Service Provider following a design or process originated and furnished by Transnet. The Supplier/Service Provider shall either

- a) procure for Transnet the right to continue using the infringing Goods; or
- b) modify or replace the Goods/Services so that they become non-infringing,

provided that in both cases the Goods/Services shall continue to meet Transnet's requirements and any specifications stipulated in the Order. Should neither option be possible, the Supplier/Service Provider may remove, with Transnet's prior written consent, such Goods/Services and will pay to Transnet a sum equivalent to the purchase price. If Transnet refuses to give such consent, the Supplier/Service Provider shall have no liability in respect of any continued use of the infringing Goods/Services after Supplier's/Service Provider's prior written request to remove the same.

6 PROPRIETARY INFORMATION

All information which Transnet has divulged or may divulge to the Supplier/Service Provider and any information relating to Transnet's business which may have come into the Supplier's/Service Provider's possession whilst carrying out an Order, and the existence of the Order, shall be treated by the Supplier/Service Provider as confidential information and shall not, without Transnet's prior written consent, be disclosed to any third party, or be used or copied for any purposes other than to perform the Order. This clause does not apply to information which is public knowledge or available from other sources other than by breach of this Term. Upon request by Transnet, the Supplier/Service Provider shall return all materials issued pursuant to the Order and, pending this, shall protect Transnet's rights in any such materials. Such confidential information shall at all material times be the property of Transnet.

7 DEVELOPMENT WORK IN THE PRODUCTION OF GOODS

If the production or provision of any Goods involves research and/or development which are wholly or partly funded by Transnet, then all intellectual property or other rights as a result thereof shall be the property of Transnet on creation.

8 PUBLICITY

The Supplier/Service Provider shall not name Transnet or use its trademarks, service marks [whether registered or not] or Goods in connection with any publicity without Transnet's prior written consent.

9 AFTER SALES SERVICE

The Supplier shall provide replacement parts necessary to ensure the uninterrupted operation of the Goods supplied for the duration of the warranty period, from delivery of any particular item of the Goods and if requested by Transnet shall make these parts available to a third party maintainer of Transnet's choice at the same price as if the parts had been supplied to Transnet. The Supplier undertakes to provide a maintenance service for Goods, should Transnet so request, or terms to be agreed. If the Order so indicates, the Supplier will provide a warranty service for the Goods at a level to be agreed with Transnet.

10 TERMINATION OF ORDER

10.1 Transnet may cancel an Order in whole or in part at any time upon at least 7 [seven] days' written notice to the Supplier/Service Provider, or when there is a change in control of the Supplier/Service Provider or the Supplier/Service Provider commits any serious breach or any repeated or continued material breach of its obligations under these Terms and/or Order or shall have been guilty of conduct tending to bring itself into disrepute, on written notice to the Supplier/Service Provider when such work on the Order shall stop.

10.2 Transnet shall pay the Supplier/Service Provider a fair and reasonable price for justified work in progress where such price reflects only those costs not otherwise recoverable by the Supplier/Service Provider, at the time of termination, and the Supplier/Service Provider shall give Transnet full assistance to check the extent of such work in progress. Payment of such price shall be in full and final satisfaction of any claims arising out of such termination and upon such payment the Supplier/Service Provider shall deliver to Transnet all work, including any materials, completed or in progress. The sum payable to the Supplier/Service Provider under this clause will not in any event exceed the total amount that would have been payable to the Supplier/Service Provider had the Order not been terminated.

10.3 In the event of termination the Supplier/Service Provider must submit all claims within 2 [two] months of termination after which time claims will only be met in what Transnet considers exceptional circumstances.

10.4 If the Goods or Services are not provided in accordance with an Order, the Order shall be deemed terminated and the Supplier/Service Provider shall compensate Transnet for any costs incurred in obtaining substitute Goods or any damage caused due to the failure or delay in the delivery.

11 ACCESS

The Supplier/Service Provider shall be liable for the acts, omissions and defaults of its personnel or agents who, for the purposes of the Order, shall be treated as if they are the Supplier's/Service Provider's

employees. The Supplier/Service Provider shall ensure that any such personnel or agents, whilst on Transnet's premises, shall comply with Transnet's health and safety, security and system security rules and procedures as and where required.

12 WARRANTY

The Supplier/Service Provider warrants that it is competent to supply the Goods/Services in accordance with these Terms to the reasonable satisfaction of Transnet and that all Goods/Services delivered under the Order: (a) conform and comply in all relevant legislation, standards, directives and orders related to *[inter alia]* the supply and use of the Goods in force at the time of delivery, and to any specifications referred to in the Order; (b) will not cause any deterioration in the functionality of any Transnet equipment; and (c) do not infringe any third party rights of any kind. The Supplier/Service Provider hereby indemnifies Transnet against all losses, liabilities, costs, claims, damages, expenses and awards of any kinds incurred or made against Transnet in connection with any breach of this warranty.

13 INSOLVENCY

If the Supplier/Service Provider shall have a receiver, manager, administrator, liquidator or like person appointed over all or any part of its assets or if the Supplier/Service Provider compounds with its creditors or passes a resolution for the writing up or administration of the Supplier/Service Provider, Transnet is at liberty to terminate the Order or Orders forthwith, or at its option, to seek performance by any such appointed person.

14 ASSIGNMENT

The Supplier/Service Provider shall not assign its obligations under an Order without Transnet's prior written consent, which consent shall not be unreasonably withheld or delayed.

15 NOTICES

Notices under these Terms shall be delivered by hand to the relevant addresses of the parties in the Order or may be served by facsimile or by email, in which event notice shall be deemed served on acknowledgement of receipt by the recipient.

16 LAW

Orders shall be governed by and interpreted in accordance with South African law and any disputes arising herein shall be subject to South African arbitration under the rules of the Arbitration Foundation of South Africa, which rules are deemed incorporated by reference in this clause. The reference to arbitration shall not prevent Transnet referring the matter to any South African courts, having jurisdiction, to which the Supplier/Service Provider hereby irrevocably submits but without prejudice to Transnet's right to take proceedings against the Supplier/Service Provider in other jurisdictions and/or obtaining interim relief on an urgent basis from a court of competent jurisdiction pending the decision in other courts or from instituting in any court of competent jurisdiction any proceedings for an interdict or any other injunctive relief. If the Supplier/Service Provider does not have a registered office in the South Africa it will at all times maintain an agent for service of process in South Africa and shall give Transnet the name and address of such agent as such may be amended, in writing, from time to time.

17 GENERAL

Completion or termination of an Order shall be without prejudice to any Term herein which by its nature would be deemed to continue after completion or termination, including but not limited to clauses **Error! Reference source not found., Error! Reference source not found., Error! Reference source not found., Error! Reference source not found.** and **Error! Reference source not found.** Headings are included herein for convenience only. If any Term herein be held illegal or unenforceable, the validity or enforceability of the remaining Terms shall not be affected. No failure or delay by Transnet to enforce any rights under these Terms will operate as a waiver thereof by Transnet. All rights and remedies available to either party under these Terms shall be in addition to, not to the exclusion of, rights otherwise available at law.

18 COUNTERPARTS

These Terms and conditions may be signed in any number of counterparts, all of which taken together shall constitute one and the same instrument. Any party may enter into this agreement by signing any such counterpart.

"PREVIEW COPY ONLY"

By signing this RFQ document, the Respondent is deemed to acknowledge that he/she has made himself/herself thoroughly familiar with all the conditions governing this RFQ, including those contained in any printed form stated to form part hereof and Transnet SOC Ltd will recognise no claim for relief based on an allegation that the Respondent overlooked any such condition or failed to properly take it into account for the purpose of calculating quoted prices or otherwise.

SIGNED at _____ on this ____ day of _____ 20__

.....
SIGNATURE OF RESPONDENT'S AUTHORISED REPRESENTATIVE

NAME: _____

DESIGNATION: _____

REGISTERED NAME OF COMPANY: _____

PHYSICAL ADDRESS:

Respondent's contact person: [Please complete]

Name
Designation
Telephone
Cell Phone :
Facsimile :
Email :
Website :



**Transnet urges its clients, suppliers and the general public to report any fraud or corruption to
TIP-OFFS ANONYMOUS : 0800 003 056**

Section 4
VENDOR APPLICATION FORM

Respondents are to furnish the following documentation and complete the Vendor Application Form below:

1. **Original** cancelled cheque **OR** letter from the Respondent's bank verifying banking details **[with bank stamp]**
2. **Certified** copy of Identity Document(s) of Shareholders/Directors/Members [where applicable]
3. **Certified** copy of Certificate of Incorporation, CM29 / CM9 [name change]
4. **Certified** copy of Share Certificates [CK1/CK2 if CC]
5. A letter on the company's letterhead confirm physical and postal addresses
6. **Original** valid SARS Tax Clearance Certificate
7. **Certified copy** of VAT Registration Certificate
8. **Certified copy** of valid Company Registration Certificate [if applicable]
9. A signed letter from your auditor or accountant confirming most recent annual turnover figures

Vendor Application Form

Company trading name							
Company registered name							
Company Registration Number or ID Number if a Sole Proprietor							
Form of entity [v]	<input type="checkbox"/> CC	<input type="checkbox"/> Trust	<input type="checkbox"/> Pty Ltd	<input type="checkbox"/> Limited	<input type="checkbox"/> Partnership	<input type="checkbox"/> Sole Proprietor	
VAT number [if registered]							
Company telephone number							
Company fax number							
Company email address							
Company website address							
Bank name				Branch & Branch code			
Account holder				Bank account number			
Postal address							Code
Physical Address							

"PREVIEW COPY ONLY"

			Code	
Contact person				
Designation				
Telephone				
Email				
Annual turnover range [last financial year]	< R5 m	R5 - 35 m	> R35 m	
Does your company provide	Products	Services	Both	
Area of delivery	National	Provincial	Local	
Is your company a public or private entity	Public	Private		
Does your company have a Tax Directive or IRP30 Certificate	Yes	No		
Main product or services [e.g. Stationery/Consulting]				

Complete B-BBEE Ownership Details:

% Black ownership		% Black women ownership		% Disabled Black ownership	
Does your company have a B-BBEE certificate	Yes	No			
What is your B-BBEE status [Level 1 to 9 / Unknown]					
How many personnel does the firm employ	Permanent	Part time			

If you are an existing Vendor with Transnet please complete the following:

Transnet contact person	
Contact number	
Transnet Operating Division	

Duly authorised to sign for and on behalf of Company / Organisation:

Name		Designation	
Signature		Date	

RESOURCE NAME	DRAWING NO.	ADDITIONAL DRAWINGS	UNIT	QUANTITY	DELIVERY PERIOD	RATE	AMOUNT
1 U-BOLT M12 HD GI	TX-8 IT1		/EA	220			
2 U BOLT M16 240*240 HD GI	TX-9 IT1		/EA	20			
3 CLEVIS PIN 16mmDiax60mm HD GI	CEE-TX-66	CEE-TX-54	/EA	360			
4 U BOLT M12 for dia 60 pipe HD GI	CEE-TX-23		/EA	1650			
5 J BOLT M16x80mm HD GI	CEE-TX-14It2		/EA	40			
6 J BOLT M16x100mm HD GI	CEE-TX-14It3		/EA	80			
7 J BOLT M16x120mm HD GI	CEE-TX-14IT4		/EA	60			
8 J BOLT M20*240 HD GI	TYR-IT 10		/EA	900			
9 U BOLT M12 HD GI -48*32crs	CEE-TX-89		/EA	30			
10 BOLT M12 * 20L HD GI			/EA	160			
11 BOLT AND NUT M12x75mm HD GI			/EA	20			
12 NUT M12 HD GI			/EA	36			
13 BOLT AND NUT M20x240mm HD GI			/EA	48			
14 FLAT WASHER M16 HD GI			/EA	40			
15 FLAT WASHER M20 HD GI			/EA	48			
16 FLAT WASHER M24 HD GI			/EA	22			
17 BOLT AND NUT M16x110mm HD GI			/EA	72			
18 BOLT AND NUT M16x140mm HD GI			/EA	40			
19 SCREW AND NUT M4X12 SLOTTED CHEESE HEAD BRASS			/EA	10			
20 BOLT AND NUT M8X40 HD GI			/EA	10			
21 BOLT AND NUT M10X40 HD GI			/EA	24			
22 BOLT AND NUT M10X115 HD GI			/EA	152			
23 BOLT AND NUT M10X255 HD GI			/EA	132			
24 BOLT AND NUT M12X25mm HD GI			/EA	20			
25 BOLT AND NUT M12X30mm HD GI			/EA	10			
26 BOLT AND NUT M12x40mm HD GI			/EA	10			
27 BOLT AND NUT M12x55mm HD GI			/EA	10			
28 BOLT AND NUT M16x140mm HD GI			/EA	10			
29 BOLT AND NUT M16X220mm HD GI			/EA	10			
30 BOLT AND NUT M20x40mm HD GI			/EA	14			

PREVIEW COPY ONLY

"PREVIEW COPY ONLY"

31	BOLT AND NUT M20x45mm HD GI	/EA	10		
32	BOLT AND NUT M20x75mm HD GI	/EA	14		
33	BOLT AND NUT M20x230mm HD GI	/EA	10		
34	BOLT AND NUT M20x255mm HD GI	/EA	20		
35	BOLT AND NUT M20x260mm HD GI	/EA	40		
36	BOLT AND NUT M20x300mm HD GI	/EA	10		
37	BOLT AND NUT M24X65L GI	/EA	60		
38	NUT M20 HD GI	/EA	895		
40	NUT M36 HD GI	/EA	2 236.00		
41	SPRING WASHER M4 HD GI	/EA	10		
42	FLAT WASHER M10 HD GI	/EA	310		
43	FLAT WASHER M12 HD GI	/EA	40		
44	WASHER FLAT M16 HD GI	/EA	40		
46	WASHER ROUND FLAT M20 HD GI	/EA	90		
47	WASHER M36 HD GI	/EA	2 236.00		
48	FLAT WASHER M16 HD GI	/EA	30		
49	BOLT AND NUT M24x260mm	/EA	30		
50	BOLT AND NUT M10X115 HD GI	/EA	10		
51	BOLT AND NUT M12X25mm HD GI	/EA	20		
52	BOLT AND NUT M12X30mm HD GI	/EA	70		
53	BOLT AND NUT M12x40mm HD GI	/EA	450		
54	BOLT AND NUT M12x65mm HD GI	/EA	30		
55	BOLT AND NUT M12X100mm HD GI	/EA	898		
56	BOLT AND NUT M16x30mm HD GI	/EA	60		
57	BOLT AND NUT M16x40mm HD GI	/EA	20		
58	BOLT AND NUT M16x45mm HD GI	/EA	30		
59	BOLT AND NUT M16x50mm HD GI	/EA	110		
60	BOLT AND NUT M16X65mm HD GI	/EA	2 416.00		
61	BOLT AND NUT M16x140mm HD GI	/EA	30		
62	BOLT AND NUT M16X150mm HD GI	/EA	10		
63	BOLT AND NUT M20x40mm HD GI	/EA	750		
64	BOLT AND NUT M20x75mm HD GI	/EA	1 348.00		
65	BOLT AND NUT M20x150mm HD GI	/EA	130		



AMENDMENT / WYSIGINGS		
No	NAME / NAAM	DATE / DATUM
1	G.R.B.	7-3-72
S.A.B.S 763. WAS CEE G3A-1.		
D.O. REF: J72/7.		
2	E. Louw	82-03-24
ASSY. DRGS. ADDED SAMEST. TEK. BY: GEVOEG.		
D.O. REF. TK-VERW. P62/10		

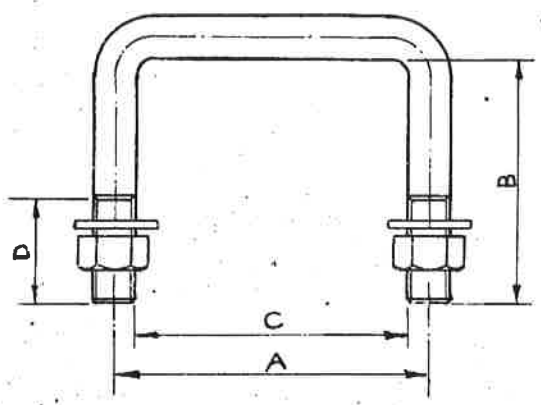

**ORDERING NOTE.
BESTELLINGNOTA.**

U BOLT DIMENSIONS / BOUT AFMETINGS A-100, B=210,
QUOTE / VERMELD ITEM NO 10 N

Nº	A	C
1	55	43
2	60	48
3	65	53
4	70	58
5	75	63
6	80	68
7	85	73
8	90	78
9	95	83
10	100	88
11	105	93
12	110	98
13	115	103
14	120	108
15	125	113
16	130	118
17	135	123
18	140	128
19	145	133
20	150	138
21	155	143
22	160	148
23	165	153
24	170	158

Nº	A	C
25	175	163
26	180	166
27	185	173
28	190	178
29	195	183
30	200	188
31	205	193
32	210	198
33	215	203
34	220	208
35	225	213
36	230	218
37	235	223
38	240	228
39	245	233
40	250	238
41	255	243
42	260	248
43	265	253
44	270	258
45	275	263
46	280	268
47	285	273
48	290	278

Nº	A	C
49	295	283
50	300	288
51	305	293
52	310	298
53	315	303
54	320	308
55	325	313
56	330	318
57	335	323
58	340	328
59	345	333
60	350	338
61	355	343
62	360	348
63	365	353
64	370	358
65	375	363
66	380	368
67	385	373
68	390	378
69	395	383
70	400	388
71	405	393
72	410	398

LETTER	B	D
A	90	50
B	100	55
C	110	60
D	120	65
E	130	70
F	140	75
G	150	80
H	160	85
J	170	90
K	180	95
L	190	100
M	200	105
N	210	110
P	220	115
Q	230	120
R	240	125
S	250	130
T	260	135
U	270	140
V	280	145
W	290	150
X	300	155
Y	310	160
Z	320	165
AA	330	170
BB	340	175
CC	350	180
DD	360	185
EE	370	190
FF	380	195
GG	390	200
HH	400	205
JJ	410	210
KK	420	215
LL	430	220
MM	440	225
NN	450	230

DIMENSIONS: MILLIMETRES / AFMETINGS: MILLIMETERS
 FINISH: ZINC COAT TO SPECIFICATION / AFWERKING: SINKBEDEK VOLGENS SPEG. S.A.B.S. 763.

D.O. REF / TK-VERW	C146/70
DRN / GET	<i>[Signature]</i>
CKD / NGS	<i>[Signature]</i>
ENGR / IR	<i>[Signature]</i>
DATE / DATUM	27-1-71

MATERIAL - MATERIAAL	STEEL / STAAL B.S. 4190.
SCALE / SKAAL	<i>[Signature]</i>

STANDARD M12 U BOLTS FOR ELECTRIFICATION / STEELWERK
STANDAARD M12 U BOUTE VIR ELEKTRIFIKASIE STAALWERK
 CHIEF ELECTRICAL ENGINEER / ELEKTROTEGNIESE HOOFINGENIEUR SAR. S.A.S. JOHANNESBURG

CEE-PFB-12,13,18,19,20	
ASSEMBLY DRG / SAMESTELTEK	
GENERAL TOLERANCES / ALGEMEEN TOLERANSIES	
FIN: +1	
ANG HOEKE	
AMENDMENT / WYSIGING	1 2
DRAWING / TEKENING No. CEE-	
TX8	

AMENDMENTS		
NO	NAME	DATE
3	L O BORCHARD	95-05-11

REDRAWN. STAINLESS STEEL ADDED AS ALTERNATIVE MATERIAL. DO REF T95/003

DIMENSIONS: mm
SCALE: 1:2

A3
 DRAWING NO CEE--
TX--9
 SHEET -- OF --

No	B	D
AA	330	57
BB	340	57
CC	350	57
DD	360	57
EE	370	57
FF	380	57
GG	390	57
HH	400	57
JJ	410	57
KK	420	57
LL	430	57
MM	440	57
NN	450	57

No	B	D
A	90	38
B	100	38
C	110	38
D	120	38
E	130	44
F	140	44
G	150	44
H	160	44
J	170	44
K	180	44
L	190	44
M	200	44
N	210	57
P	220	57
Q	230	57
R	240	57
S	250	57
T	260	57
U	270	57
V	280	57
W	290	57
X	300	57
Y	310	57
Z	320	57

No	A	C
49	295	279
50	300	284
51	305	289
52	310	294
53	315	299
54	320	304
55	325	309
56	330	314
57	335	319
58	340	324
59	345	329
60	350	334
61	355	339
62	360	343
63	365	349
64	370	354
65	375	359
66	380	364
67	385	369
68	390	374
69	395	379
70	400	384
71	405	389
72	410	394

No	A	C
25	175	159
26	180	164
27	185	169
28	190	174
29	195	179
30	200	184
31	205	189
32	210	194
33	215	199
34	220	204
35	225	209
36	230	214
37	235	219
38	240	224
39	245	229
40	250	234
41	255	239
42	260	244
43	265	249
44	270	254
45	275	259
46	280	264
47	285	269
48	290	274

No	A	C
1	55	39
2	60	44
3	65	49
4	70	54
5	75	59
6	80	64
7	85	69
8	90	74
9	95	79
10	100	84
11	105	89
12	110	94
13	115	99
14	120	104
15	125	109
16	130	114
17	135	119
18	140	124
19	145	129
20	150	134
21	155	139
22	160	144
23	165	149
24	170	154

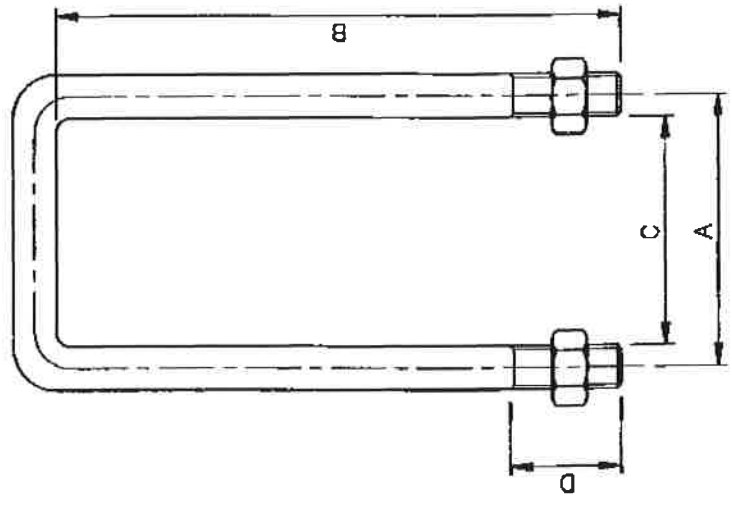

ORDERING NOTE EXAMPLE
U-BOLT DIMENSIONS A=100, B=210
QUOTE ITEM No 10N

NOTE
ZINC COAT MILD STEEL TO SPEC SABS 763 FOR CONDITIONS IN SITU

PRELIMINARY COPY ONLY

MATERIAL: ITEM NO 11/ — STEEL, ROUND, Ø16 OR STAINLESS STEEL, ROUND

DO REF: C146/70 GEN TOL: LINE 1 ANGE —

DRN: N W L CKD: E F J DATE: XXX

ENG: — F PIENAAR for CHIEF ENG

INFRASTRUCTURE (ELECTRICAL)

SPOORNET

STANDARD M16 U-BOLTS FOR ELECTRIFICATION STEELWORK

ITEM	DESCRIPTION	QTY	STORES ITEM NO	DRG NO CEE--	AMENDMENTS
1	RIVET, STEEL, SNAP HEAD, $\phi 16$ x 60 LG	1	01/22722		NO NAME DATE
2	LOCKING SPLIT PIN	1	54/3734	TX-54	3 J V DYK 94/8/4

DIMENSION 50 WAS 46. TOL REVISED. ITEM 1 STORES ITEM NO WAS 01/22710. DO REF T94/046

STORES ITEM NO. 54/4020
DIMENSIONS: mm SCALE: 1:1
 A4
DRG NO CEE-- TX-66
SHT -- OF --

"PREVIEW COPY ONLY"

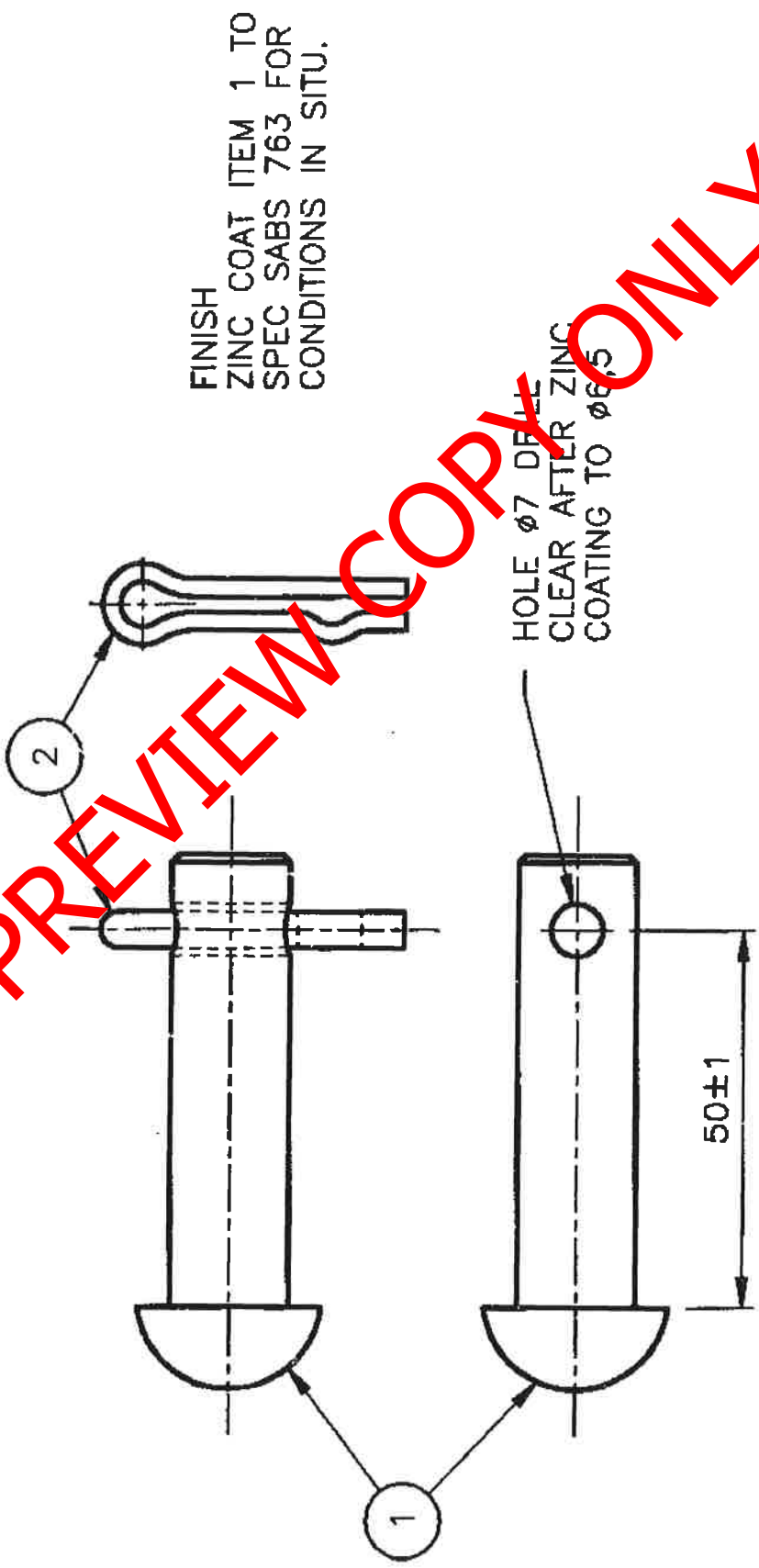

DO REF: C84/70	GEN TOL: LIN \pm 0,5	ANG \pm —
DRN: G.J. v G.	CKD: I.T.	DATE: 70-09-09
ENG: —	T.C. BROOK	for CHIEF ENG
INFRASTRUCTURE (ELECTRICAL)		
 SPOORNET		
PIN, STRAIGHT, HEADED, $\phi 16$ WITH LOCKING SPLIT PIN		

AMENDMENTS		
NO	NAME	DATE
2	J v DŸK	94-8-4
DRG REVISED.		
DO REF T94/046		
3	J HARCUS	98-6-25
PIN DIAMETER WAS $\phi 4,8/\phi 4,74$		
DO REF: T98/028		

STORES ITEM NO.
54/3734

DIMENSIONS: mm
SCALE: 2:1



DRG NO CEE-
TX-54
SHT — OF —

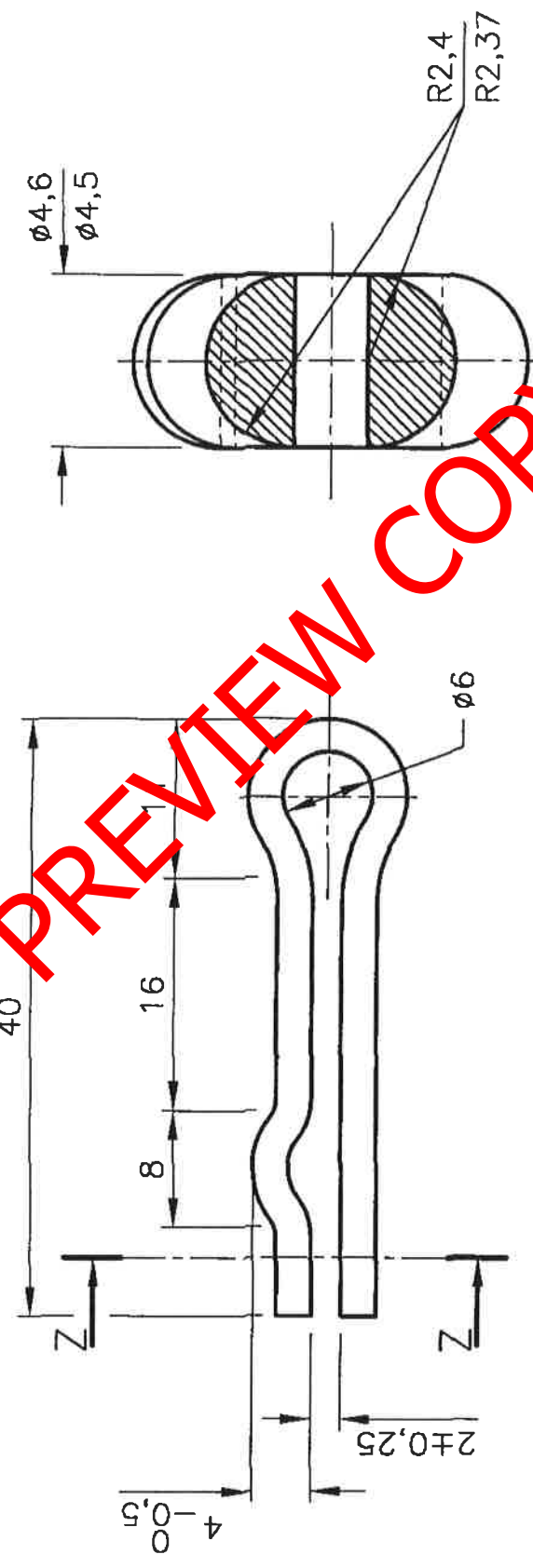

"PREVIEW COPY ONLY"

SECTION Z - Z
SCALE 5:1

MATERIAL: ITEM NO —, BRASS TO SPEC BS 2873/CZ 108 OR STAINLESS STEEL TO SPEC BS 970 GRADE 316S16

DO REF: N37/69	GEN TOL: LIN ± 0,5	ANG ± —
DRN: C.J.S.	CKD: R.N.	DATE: 69-03-03
ENG: F PIENAAR	F PIENAAR	for CHIEF ENG
INFRASTRUCTURE (ELECTRICAL)		SPOORNET

COTTER PIN

ITEM	DESCRIPTION ~ BESKRYWING	QTY HVLD	STORES MAGASYN NO.	AMENDMENTS WYSIGINGS
1.	STEEL, ROUND ϕ 12 x 225 L TO SPEC. CME 9 SYM 7 STAAI, ROND	1.	(M) 1/2740	NO. NAME DATE NAAM DATUM
2.	NUT, PLAIN, HEX, STEEL, GALV. MOER, GEWONE, SEK, STAAL, GEGALV. M12	2.	(M) 1/32856	2. B. Stewart 82-04-22
3.	WASHER, FLAT, STEEL, ROUND, NORMAL, GALV. WASTER, PLAT, STAAL, ROND, NORMAAL, GEGALV. M12.	2.	(M) 1/33659	REDRAWN IN INK. OORGETEKEN IN INK.

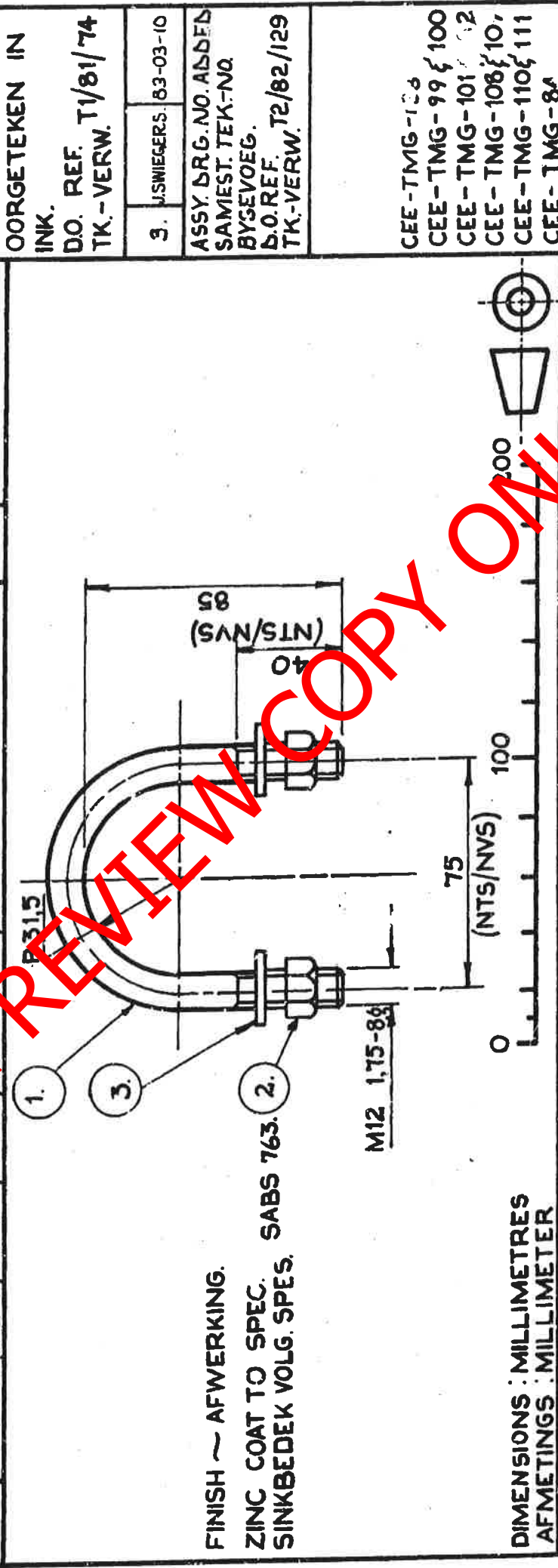

FINISH ~ AFWERKING.		D.O. REF. T1/81/74 TK.-VERW.	
ZINC COAT TO SPEC. SABS 763.		3. J.SNIEGERS. 83-03-10	
SINKBEDEK VOLG. SPES.		ASSY. DRG. NO. ADDED SAMEST. TEK.-NO. BYSEVOEG. D.O. REF. T2/82/129 TK.-VERW.	
DIMENSIONS : MILLIMETRES AFMETINGS : MILLIMETER		CEE-TMG-108 CEE-TMG-99 & 100 CEE-TMG-101 & 102 CEE-TMG-108 & 107 CEE-TMG-110 & 111 CEE-TMG-84 ASSY. DRG. SAMEST. -TEK.	
DRN. B. v.d. WEST.	GEN. TOLERANCES : LIN. \pm 0,5	DRAWING NO. CEE- TEKENING	
TRCD. K. HUGHES	ALG. TOLERANSIES: ANG./HOEK \pm ---	TX-23	
NGT. ---	D.O. REF. --- TK.-VERW. IR.		
CKD. R.A. MACMILLAN	DATE 80-02-13		
NGS. ---	DATUM: G.A. WILLIAMS		
CHIEF ELECTRICAL ENGINEER	JOHANNESBURG		
ELEKTRIESE HOOFINGENIEUR			
SOUTH AFRICAN TRANSPORT SERVICES			
SUID - AFRIKAANSE VERVOERDIENSTE			

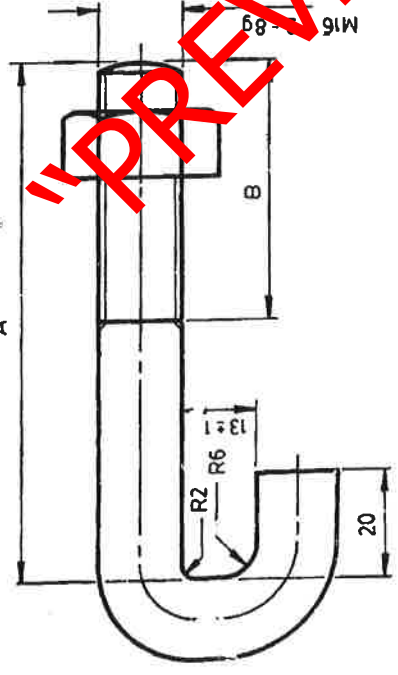

NOTES / OPMERKINGS

1. FABRICATION: FORM HOOK AT 875° - 900°C.
VERVAARDIGING: VORM HAAK TEEN 875° - 900°C.
2. NORMALISE: REHEAT UNIFORMLY THROUGHOUT TO 875° - 900°C AND ALLOW TO COOL FREELY IN AIR.
NORMALISEER: HERVERWARM HEELTEMAL TOT 875° - 900°C EN LAAT AFKOEL IN LUG.
3. FINISH: ZINC COAT TO SPEC. SABS 763.
AFWERKING: SINKBEDEK VOLG. SPES.

DIMENSIONS: MILLIMETRES
AFMETINGS: MILLIMETER

MATERIAL - MATERIAAL
STEEL, ROUND 16
STAAL, ROND 16
TO BS 4360 GRADE 43A.
VOLG. GRAAD
OR CME 9 SYMBOL 8.
OF SIMBOOL 8.

DRN. GET.	F. W. C.	GEN. TOLERANCES: LIN. ±2	ALG. TOLERANSIES: ANG/HOE.: —
TRCD. NGT.	S. v. VUUREN	D.O. REF. TK-VERW	ENG. J. S. SMUTS
CKD. NGS.	W. R. G.	DATE 45-12-14	C. BOTHA for ns.
CHIEF ELECTRICAL ENGINEER		JOHANNESBURG	
ELEKTRIESE HOOFINGENIEUR		JOHANNESBURG	
SOUTH AFRICAN TRANSPORT SERVICES		SUID-AFRIKAANSE VERVOERDIENSTE	

ELECTRIFICATION TYPE: GENERAL

BOLT, HOOK, M16.

AND HEX. NUT.

ELEKTRIFIKASIE TYP: ALGEMEEN.

BOUT, HAAK-, M16.

EN SESK. MCTR.

ITEM	DIM. / AFM.		STORES ITEM NO MAGASYNITEM	AMENDMENTS WYSIGINGS	
	A	B		NO.	NAME NAAM
1	60	30	(M)54/3443		
2	80	50	(M)54/3455		85-8-14
3	100	50	(M)54/3467		
4	120	50	(M)54/3479		
5	140	50	(M)54/3480		
6	160	50	(M)54/3492		
7	180	50	(M)54/3507		
8	200	50	(M)54/3519		
9	220	50	(M)54/3520		
10	240	50	(M)54/3532		
11	260	50	(M)54/3544		
12	280	50	(M)54/3556		
13	300	50	(M)54/3568		
14	550	70			
15					

REDRAWN AND REVISED.
OORGETEKEN EN HERSIEN.
MOD. ITEM NO'S ADDED.
D.O. REF. T1/85/74.
TK-VERW.

CLASS/ASSY. DRG.
KLAS/SAMEST.-TEK.
MODULUS ITEM NO.

PREVIOUS ITEM NO.
VORIGE

DRAWING NO. CEE-
TEKENING TX-14

SHEET NO. OF
VEL VAN

PREVIEW COPY ONLY

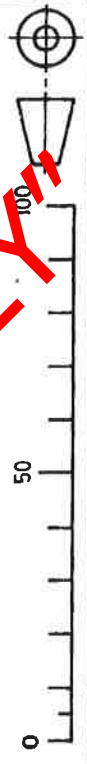

ORIGINAL FRAME SIZE
OORSPRONKLIKE RAAMGROOTTE 267 x 180.

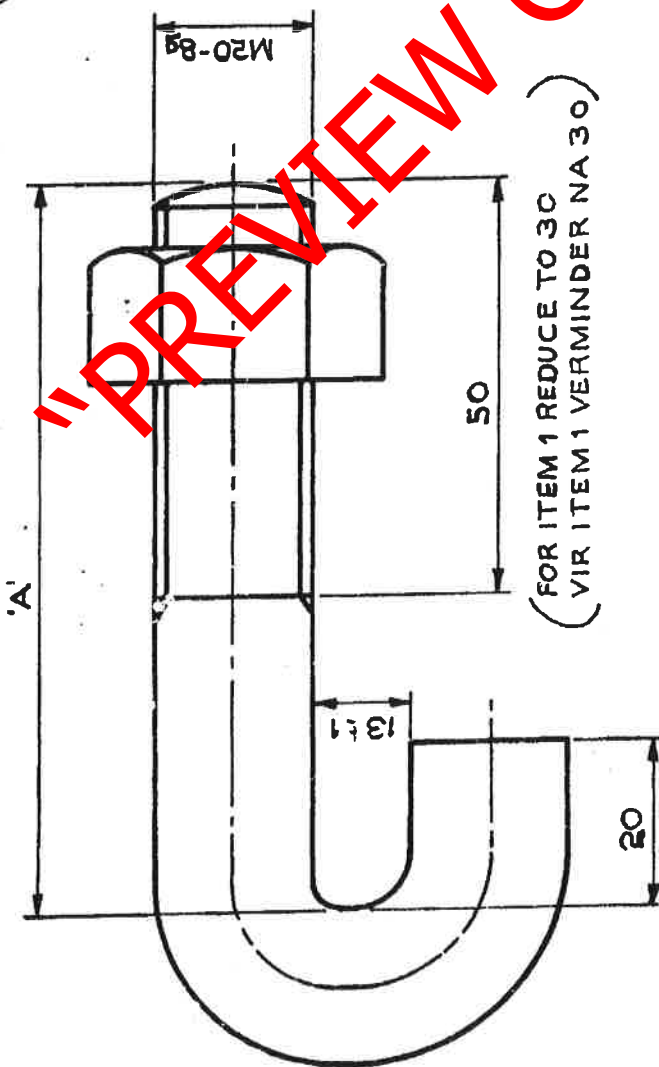

(FOR ITEM 1 REDUCE TO 30
VIR ITEM 1 VERMINDER NA 30)

FABRICATION: FORM HOOK AT 875° - 900°C.
VERVAARDIGING: VORM HAAK BY

NORMALISE: REHEAT UNIFORMLY THROUGHOUT TO 875° - 900°C. AND ALLOW TO COOL FREELY IN AIR.
NORMALISEER: HERVERWARM HEELTEMAL TOT 875° - 900°C EN LAAT AFKOEL IN LUG.

FINISH: ZINC COAT TO SPECIFICATION S.A.B.S. 763.
AFWERKING: SINKBEDEK VOLGENS SPES.

DIMENSIONS: MILLIMETRES.
AFMETINGS: MILLIMETERS.

MATERIAL ~ MATERIAAL.
STEEL TO B.S. 4360 GRADE 43A
STAAL VOLG. B.S. 4360 GRAAD 43A
OR CME SYMBOL 8.

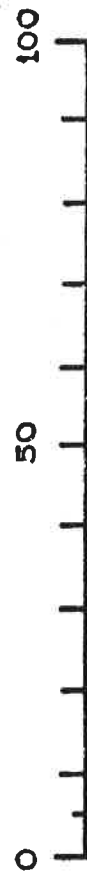

GENERAL TOLERANCES. LIN. ± 2 ALGEMENE TOLERANSIES.		ANG. — HOEK.
DRN. R.L. GET.	CKD. F.W.C. NGS.	ENG. J. Smuts.
D.O. REF. — T.K. VERW. —	DATE. 11-5-46 DATUM.	C. Botha -f.e.s.-
CHIEF ELECTRICAL ENGINEER ELEKTROTEGNIËSE HOOFINGENIEUR		SAR. JOHANNESBURG. SAS.

ITEM	DIM. 'A' AFM.	STORES MAGASYN	ITEM No
1	60		
2	80		
3	100		
4	120		
5	140		
6	160		
7	180		
8	200		
9	220		
10	240		
11	260		
12	280		
13	300		

AMENDMENTS. WYSIGINGS.		
No.	NAME NAAM	DATE. DATUM.
1	<i>June</i>	26-10-72

REDRAWN AND METRICATED. DRG. No. HERTEKEN EN METRISEER. TEK. No. WAS CEE - 156. WAS CEE - 156. D.O. REF. C95/72 T.K. VERW.

M 20: HOOK BOLTS.
M 20: HAAKBOUTE.

ASSY. DRG./ SAMES. TEK
DRAWING. No. CEE
TEKENING. No. CEE
TX 15.

"PREVIEW COPY ONLY"

"PREVIEW COPY ONLY"

<table border="1" style="width: 100%; border-collapse: collapse;"> <tr> <th colspan="2">AMENDMENTS</th> </tr> <tr> <th style="width: 50%;">NO</th> <th style="width: 50%;">DATE</th> </tr> <tr> <td>4</td> <td>L. O. BURCHARD/95-05-11</td> </tr> <tr> <td colspan="2">REDRAWN, STAINLESS STEEL ADDED.</td> </tr> <tr> <td colspan="2">DO REF 195/003</td> </tr> </table>	AMENDMENTS		NO	DATE	4	L. O. BURCHARD/95-05-11	REDRAWN, STAINLESS STEEL ADDED.		DO REF 195/003		<p style="text-align: center;">NOTE ZINC COAT MILD STEEL TO SPEC SABS 763 FOR CONDITIONS IN SITU</p>	<table border="1" style="width: 100%; border-collapse: collapse;"> <tr> <td colspan="2">DIMENSIONS: mm</td> </tr> <tr> <td colspan="2">SCALE: 1:1</td> </tr> <tr> <td style="text-align: center;"> </td> <td style="text-align: center;">A4</td> </tr> <tr> <td>DRN: G N</td> <td>DATE: 71-03-25</td> </tr> <tr> <td>ENG: -</td> <td>F PIENAAR for CHIEF ENG</td> </tr> </table>	DIMENSIONS: mm		SCALE: 1:1			A4	DRN: G N	DATE: 71-03-25	ENG: -	F PIENAAR for CHIEF ENG
AMENDMENTS																						
NO	DATE																					
4	L. O. BURCHARD/95-05-11																					
REDRAWN, STAINLESS STEEL ADDED.																						
DO REF 195/003																						
DIMENSIONS: mm																						
SCALE: 1:1																						
	A4																					
DRN: G N	DATE: 71-03-25																					
ENG: -	F PIENAAR for CHIEF ENG																					
<p>MATERIAL: ITEM NO 11/ --- STEEL, ROUND, $\phi 12$ X 127 LG OR STAINLESS STEEL</p> <p>DO REF: C29/71 GEN TOL: LINE 1 ANG± -</p> <p>INFRASTRUCTURE (ELECTRICAL)</p>		<p>U-BOLT M12</p> <p style="text-align: center;"> SPOORNET</p>																				

T0000776

3

4

4

4

3

ITEM	DESCRIPTION / BESKRYWING.	QTY. HVLD.	STORES MAGASYN	DRG. NO. TEK.	AMENDMENTS WYSIGINGS
1.	RIVET, STEEL, SNAP HEAD. KLINKNAEL, STAAL, GESNAPTE	1.			NO. NAME DATE NO. NAAM DATUM
2.	LOCKING SPLIT PIN. BORGSPPLITPEN.	1.	54/112102.	-54/112102.	

FINISH / AFWERKING.
ZINC COAT ITEM 1. TO : SABS 763.
SINKBEDEK ITEM 1. VOLG :

DRILL BOOR
CLEAR AFTER ZINC COATING TO Ø 6,5.
RUIIM NA SINKBEDEKKING NA Ø 6,5.

DIMENSIONS : MILLIMETRES.
AFMETINGS : MILLIMETER.

SOUTH AFRICAN TRANSPORT SERVICES
SUID - AFRIKAANSE VERVOERDIENSTE

GEN. TOLERANCES : LIN.
ALG. TOLERANSIES : ANG./HOEK.

DRN. R. KIECK.
GET.

TRCD. S. ROBERTSON
NGT.

D.O. REF. 78
TK-VERW. IR.

CKD. R. KIECK
NGS.

DATE 20/11/1991
DATUM

CHIEF ELECTRICAL ENGINEER
ELEKTRIESE

JOHANNESBURG

PIVOT PIN Ø 16.
WITH LOCKING SPLIT PIN.
SPILPEN Ø 16.
MET BORGSPPLITPEN.

ITEM NO
DRAWING NO CEE
TEKENING NO CEE
-TN-243.

ITEM	DESCRIPTION	QTY	STORES ITEM NO	DRG NO CEE-	AMENDMENTS			
					NO	NAME	DATE	
1	STAY BOLT	1		TNE-31	SHT 2	1	J HARCUS	95-08-21
2	FIN	1		TNE-31	SHT 3			
3	NUT, STEEL, GALV, HEX, M36	2	1/32921					
4	WASHER, FLAT, STEEL, GALV, ROUND, M36	1	1/33700					

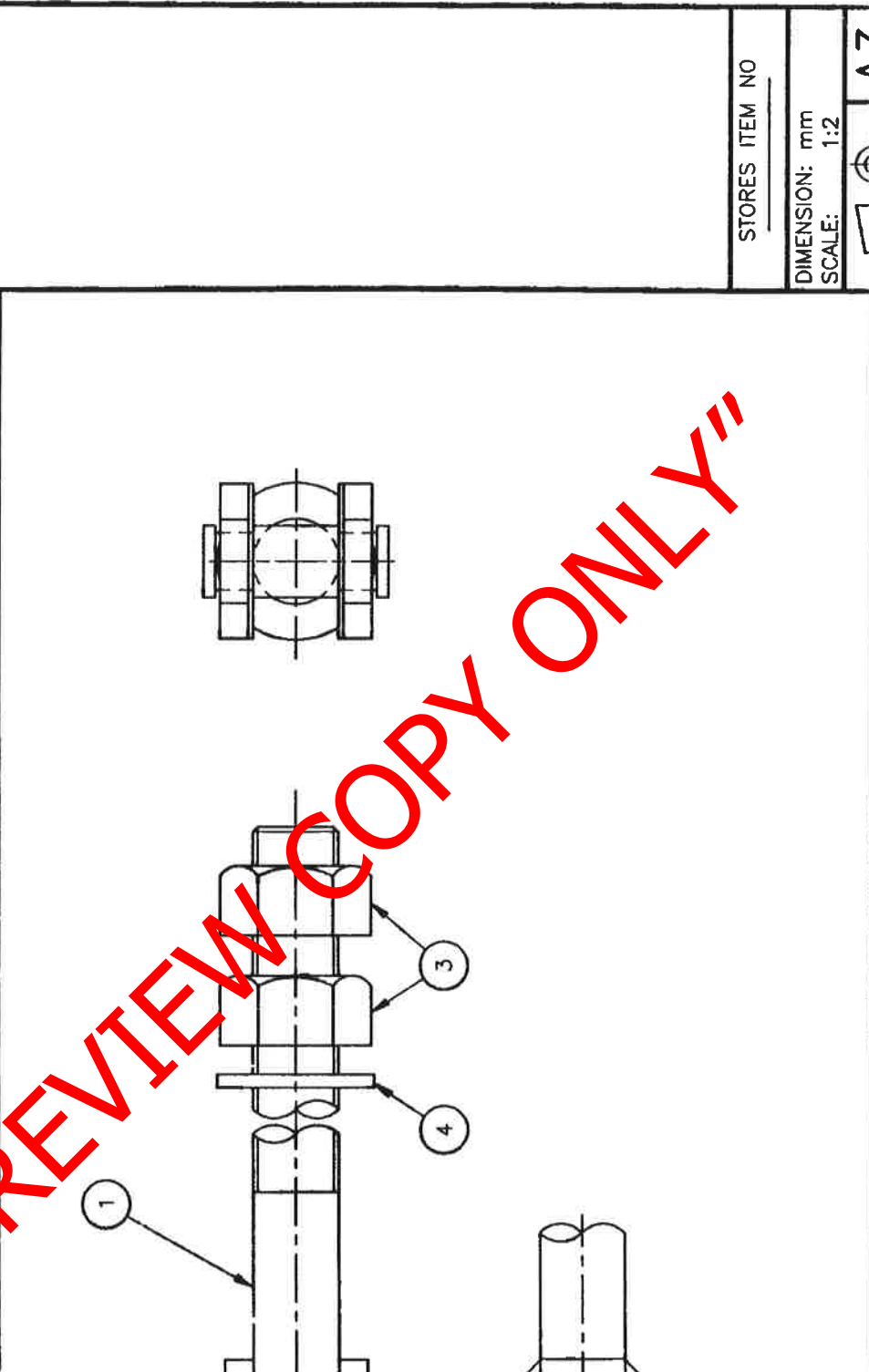

STORES ITEM NO	
DIMENSION: mm	
SCALE:	1:2
	A3
DRAWING NO	CEE-
	TNE-31
SHEET	1 OF 3

STAY BOLT ASSEMBLY
STAY WIRE

DO REF:	T79/20	GEN TOL:	LINE	ANG±	-
DRN:B v d	WESTH	CKD:	J SWIEGERS	DATE:	90-07-28
ENG:	-		GA WILLIAMS		for CHIEF ENG
INFRASTRUCTURE (ELECTRICAL)		SPOORNET			

AMENDMENTS		
NO	NAME	DATE
3	JVT	97-09-05

DRAWING REVISED.
DO REF: T96/021

ITEM	DESCRIPTION	QTY	STORES ITEM NO	DRG NO CEE-
1	PIN, STRAIGHT, HEADED, MILD STEEL, $\phi 24$ *	1	1/	
2	PIN, COTTER, BRASS, $\phi 6.3$ x .36 LG	1	54/3795	

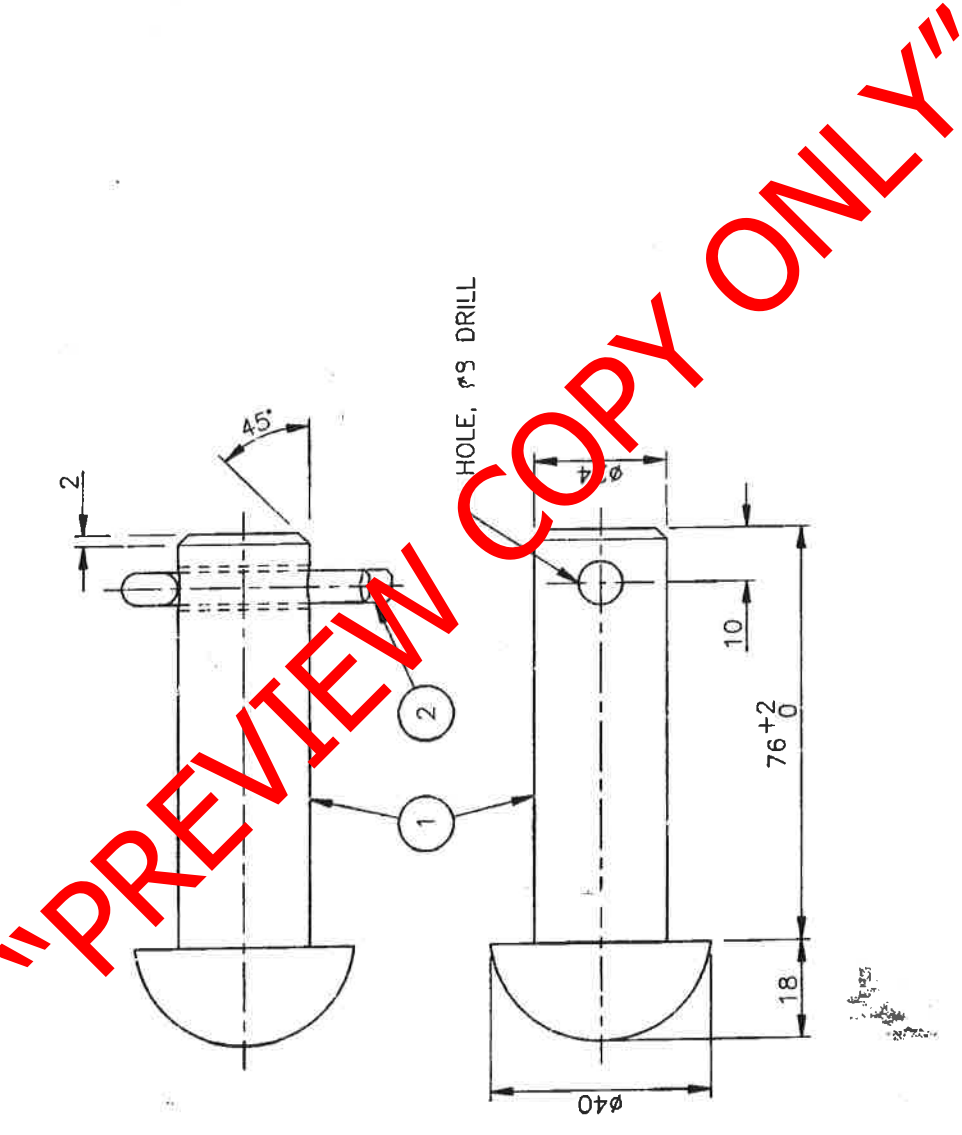

* FINISH
ZINK COAT ITEM 1 TO SABS 763 FOR CONDITIONS IN SITU.

STORES ITEM NO
54/4007

DIMENSIONS: mm
SCALE: 1:1

A3

DRAWING NO CEE-

TX-59

SHEET -- OF --

DO REF: C227/68	GEN TOL: LIN± 0.5	ANG± 1°
DRN: M.K.	CKD: F.W.C.	DATE: 69-04-18
ENG: R.C.K.	W ROGERS for CHIEF ENG	
INFRASTRUCTURE (ELECTRICAL)		
SPOORNET		

PIN, STRAIGHT, HEADED, $\phi 24$ x 76 LG
COMPLETE WITH COTTER PIN.

AMENDMENTS		
NO	NAME	DATE
3	JVT	97-9-5

DRAWING REVISED.
DO REF:T96/021

STORES ITEM NO. _____

DIMENSIONS: mm
SCALE: 1:1

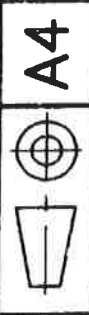

DRG NO CEE--
TX-28
SHT -- OF --

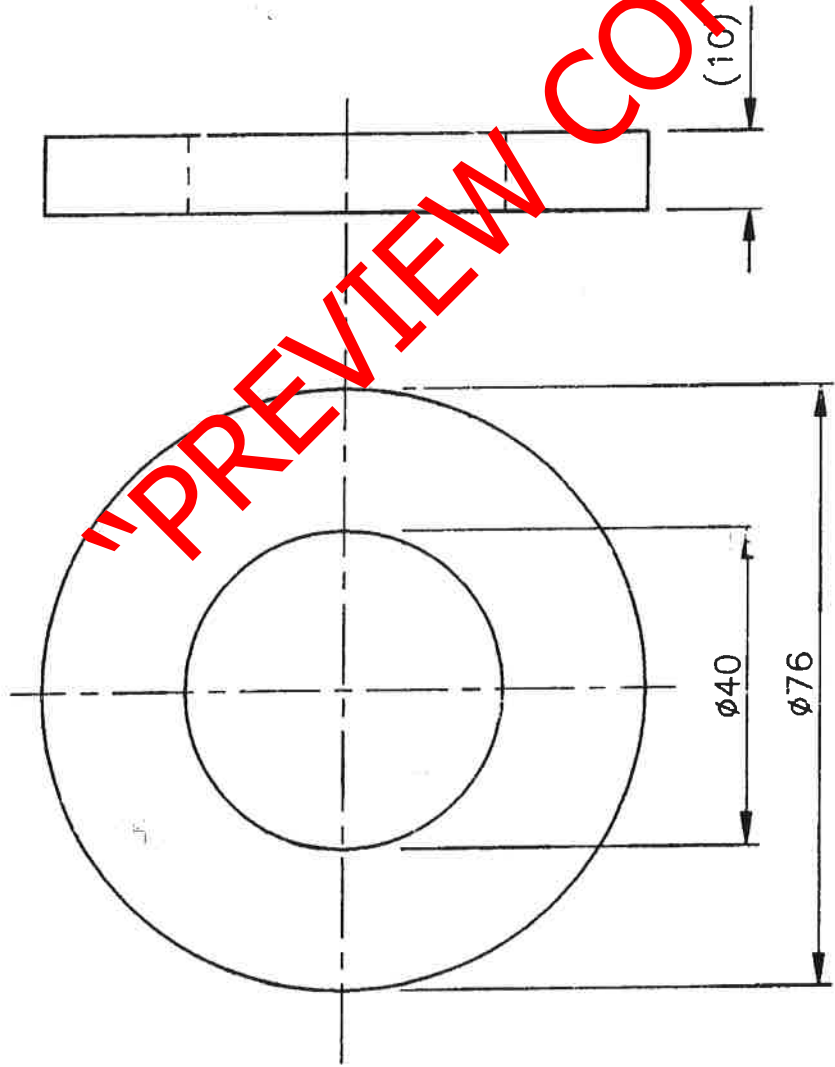

FINISH: ZINC COAT TO SABS 763 FOR CONDITIONS IN SITU.

MATERIAL: STORES ITEM NO 11/12408, STEEL, FLAT, 80 x 10 THK

DO REF: T79/20 GEN TOL: LIN± 0.5 ANG± —

DRN: A JOUBERT CKD: J SWIGERS DATE: 80-07-28

ENG: — GA WILLIAMS for CHIEF ENG

INFRASTRUCTURE (ELECTRICAL)
 SPOORNET

WASHER, PACKING

CROSS HEAD, STAY WIRE ANCHOR