

Transnet Freight Rail, a division of

TRANSNET SOC LTD

Registration Number 1990/000900/30

[hereinafter referred to as **Transnet**]

REQUEST FOR QUOTATION [RFQ] No SAZ52744

**FOR THE SUPPLY OF: GARDENING SERVICES AND REMOVAL OF
DOMESTIC WASTE AT HALFWEG
(24 month contract period)**

ISSUE DATE: 12 March 2014

CLOSING DATE: 25 March 2014

CLOSING TIME: 10:00

Respondent's Signature

Date & Company Stamp

REQUEST FOR QUOTATION [RFQ] No SAZ52744

FOR THE SUPPLY OF: GARDENING SERVICES AND REMOVAL OF DOMESTIC WASTE AT HALFWEG

RFQ NUMBER	SAZ52744
ISSUE DATE:	12 March 2014
CLOSING DATE:	25 March 2014
CLOSING TIME:	10:00
BID VALIDITY PERIOD:	60 days from Closing Date

Enclosures:

RFQ – Sections 1, 2, 3, 4 and 5

Declaration Form

Annexure A – Project Specifications – maintenance of gardens and grounds at Halfweg

Annexure B – Project Specifications - removal of domestic waste at Halfweg

Annexure C - Special Conditions

Annexure D – Plan LSL0012m

Annexure E – Plan LSL0013m

Annexure F - Plan LSL0010m

Annexure G – Plan LSL0011m

E7/1 document

Respondent's Signature

Date & Company Stamp

Section 1
NOTICE TO BIDDERS

Quotations which must be completed as indicated in Section 2 of this RFQ are to be submitted as follows:

METHOD: [post and/or courier]
CLOSING VENUE: [courier and/or tender box at physical address]

1 Quotations which must be completed as indicated in Section 2 of this RFQ are to be submitted as follows:

2 **CLOSING VENUE:** SEE BELOW FOR CLOSING VENUE

Proposals must reach the Secretariat, Acquisition Council before the closing hour on the date shown below, and must be enclosed in a sealed envelope which must have inscribed on the outside:

RFQ No: SAZ52744

Description GARDENING SERVICES AND REMOVAL OF DOMESTIC WASTE AT HALFWEG

Closing date and time: 25 March 2014 AT 10:00 Sharp

Closing address [refer to options in Delivery Instructions for RFQ below]

A. DELIVERY INSTRUCTIONS FOR RFQ

Delivery by hand

If delivered by hand, the envelope is to be deposited in the Transnet tender box which is located at the main entrance of Transnet Park, ROBERT SOBUKWE Road, Bellville, and should be addressed as follows:

THE SECRETARIAT
ACQUISITION COUNCIL
TRANSNET PARK
TENDER BOX
ROBERT SOBUKWE ROAD
BELLVILLE 7535

The measurements of the "tender slot" are 400mm wide x 100mm high, and Respondents must please ensure that response documents or files are no larger than the above dimensions. Responses which are too bulky [i.e. more than 100mm thick] must be split into two or more files, and placed in separate envelopes, each such envelope to be addressed as above.

Respondent's Signature

Date & Company Stamp

Dispatch by courier

If dispatched by courier, the envelope must be addressed as follows and delivered to the Office of The Secretariat, Acquisition Council and a signature obtained from that Office:

THE SECRETARIAT
TRANSNET ACQUISITION COUNCIL
6TH FLOOR
TRANSNET PARK
ROBERT SOBUKWE ROAD
BELLVILLE

B. COMPULSORY INFORMATION BRIEFING MEETING

A compulsory information briefing session will be conducted at Halfweg (Loop 10), on the 19 March 2014, at 11:00 for a period of 1 hour (**respondent to provide own transportation and accommodation**) .

3 Responses to RFQ

Responses to this RFQ [**Quotations**] must not include documents or reference relating to any other quotation or proposal. Any additional conditions must be embodied in an accompanying letter.

4 Broad-Based Black Economic Empowerment [B-BBEE]

Transnet fully endorses and supports the Government's Broad-Based Black Economic Empowerment Programme and it would therefore prefer to do business with local business enterprises who share these same values. Transnet will accordingly allow a "preference" to companies who provide a valid B-BBEE Verification Certificate. All procurement transactions will be evaluated accordingly.

4.1 B-BBEE Scorecard and Rating

As prescribed in terms of the Preferential Procurement Policy Framework Act (PPPFA), Act 5 of 2000 and its Regulations, Respondents are to note that the following preference point system is applicable to all bids:

- the 80/20 system for requirements with a Rand value of up to R1 000 000 (all applicable taxes included).
- Bidders are to note that if the 80/20 preference point system is stipulated in this RFP and all Bids received exceed R1 000 000.00, the RFP must be cancelled.

The value of this bid is estimated to be below R1000 000 (all applicable taxes included) and therefore the **80/20** system shall be applicable.

When Transnet invites prospective suppliers to submit Proposals for its various expenditure programmes, it requires Respondents to have their B-BBEE status verified in compliance with the Codes of Good Practice issued in terms of the Broad Based Black Economic Empowerment Act No. 53 of 2003.

The Department of Trade and Industry recently revised the Codes of Good Practice on 11 October 2013 [Government Gazette No. 36928]. The Revised Codes will replace the Black Economic Empowerment Codes of Good Practice issued on 9 February 2007. The Revised Codes provide for a one year transitional period starting 11 October 2013. During the transitional period, companies may elect to be measured in terms of the Revised Codes or the 2007 version of the Codes. After the first year of the implementation of the Revised Codes, B-BBEE compliance will be measured in terms of the Revised Codes without any discretion. Companies which are governed by Sector-specific Codes will be measured in terms of those Sector Codes.

As such, Transnet will accept B-BBEE certificates issued based on the Revised Codes. Transnet will also continue to accept B-BBEE certificates issued in terms of the 2007 version of the Codes provided it was issued before 10 October 2014. Thereafter, Transnet will only accept B-BBEE certificates issued based on the Revised Codes.

Respondents are required to complete Annexure A [the B-BBEE Preference Point Claim Form] and submit it together with proof of their B-BBEE Status as stipulated in the Claim Form in order to obtain preference points for their B-BBEE status.

Note: Failure to submit a valid and original B-BBEE certificate or a certified copy thereof at the Closing Date of this RFQ will result in a score of zero being allocated for B-BBEE.

[Refer clause 21 below for Returnable Documents required]

5 Communication

- a) Respondents are warned that a response will be liable for disqualification should any attempt be made by a Respondent either directly or indirectly to canvass any officer(s) or employee of Transnet in respect of this RFQ between the closing date and the date of the award of the business.
- b) A Respondent may, however, before the closing date and time, direct any written enquiries relating to the RFQ to the following Transnet employee:
- Name: Cobus Carstens Email: cobus.carstens@transnet.net
- c) Respondents may also, at any time after the closing date of the RFQ, communicate with Johanna.kotze@transnet.net or carol.swan@transnet.net on any matter relating to its RFQ response:

6 Tax Clearance

The Respondent's original and valid Tax Clearance Certificate must accompany the Quotation. Note that no business shall be awarded to any Respondent whose tax matters have not been declared by SARS to be in order.

7 VAT Registration

The valid VAT registration number must be stated here: _____ *[if applicable].*

8 Legal Compliance

The successful Respondent shall be in full and complete compliance with any and all applicable national and local laws and regulations.

9 Changes to Quotations

Changes by the Respondent to its submission will not be considered after the closing date and time.

10 Pricing

All prices must be quoted in South African Rand, excluding VAT.

11 Prices Subject to Confirmation

Prices quoted which are subject to confirmation will not be considered.

12 Negotiations

Transnet reserves the right to undertake post-tender negotiations with selected Respondents or any number of short-listed Respondents.

13 Binding Offer

Any Quotation furnished pursuant to this Request shall be deemed to be an offer. Any exceptions to this statement must be clearly and specifically indicated.

14 Disclaimers

Transnet is not committed to any course of action as a result of its issuance of this RFQ and/or its receipt of a Quotation in response to it. Please note that Transnet reserves the right to:

- modify the RFQ's goods / service(s) and request Respondents to re-bid on any changes;
- reject any Quotation which does not conform to instructions and specifications which are detailed herein;
- disqualify Quotations submitted after the stated submission deadline;
- not necessarily accept the lowest priced Quotation;
- reject all Quotations, if it so decides;
- place an order in connection with this Quotation at any time after the RFQ's closing date;
- award only a portion of the proposed goods / service/s which are reflected in the scope of this RFQ;
- split the award of the order/s between more than one Supplier/Service Provider; or
- make no award at all.

Transnet reserves the right to award business to the highest scoring bidder/s unless objective criteria justify the award to another bidder.

15 Transnet's supplier integrity pact

Transnet's Integrity Pact requires a commitment from suppliers and Transnet that they will not engage in any corrupt and fraudulent practices, anti-competitive practices; and act in bad faith towards each other. The Integrity Pact also serves to communicate Transnet's Gift Policy as well as the remedies available to Transnet where a Respondent contravenes any provision of the Integrity Pact.

Respondent's Signature

Date & Company Stamp

Respondents are required to familiarise themselves with the contents of the Integrity Pact which is available on the Transnet Internet site [www.transnet.net/Tenders/Pages/default.aspx] or on request. Furthermore, Respondents are required to certify that they have acquainted themselves with all the documentation comprising the Transnet Integrity Pact and that they fully comply with all the terms and conditions stipulated in the Transnet Supplier Integrity Pact as follows:

YES		NO	
------------	--	-----------	--

Should a Respondent need to declare previous transgressions or a serious breach of law in the preceding 5 years as required by Annexure A to the Integrity Pact, such declaration must accompany the Respondent's bid submission.

16 Evaluation Criteria

Transnet will utilise the following criteria [not necessarily in this order] in choosing a Supplier/Service Provider, if so required:

Criterion/Criteria	Explanation
Administrative responsiveness	Completeness of response and returnable documents
Substantive responsiveness	Prequalification criteria, if any, must be met and whether the Bid materially complies with the scope and/or specification given.
Previous performance	Supply documentary evidence of previous performance / experience of ability to maintain, operate and control a water treatment plant and vigorously undertake duties of the specification
Certificate	Supply a Disposal Certificate

17 Validity Period

Transnet desires a validity period of 60 [sixty] days from the closing date of this RFQ.

This RFQ is valid until _____.

18 Banking Details

BANK: _____

BRANCH NAME / CODE: _____

ACCOUNT HOLDER: _____

ACCOUNT NUMBER: _____

19 Company Registration

Registration number of company / C.C. _____

Respondent's Signature

Date & Company Stamp

Registered name of company / C.C. _____

20 Disclosure of Prices Quoted

Respondents must indicate here whether Transnet may disclose their quoted prices and conditions to other Respondents:

YES NO

21 Returnable Documents

Returnable Documents means all the documents, Sections and Annexures, as listed in the tables below.

- a) Respondents are required to submit with their Quotations the **Returnable Documents**, as detailed below.

Failure to provide all these Returnable Documents at the Closing Date and time of this RFQ may result in a Respondent's disqualification. Respondents are therefore urged to ensure that all these Documents are returned with their Quotations.

All Sections, as indicated in the footer of each page, must be signed, stamped and dated by the Respondent. Please confirm submission of these Returnable Documents by so indicating [Yes or No] in the table below:

Returnable Documents	Submitted [Yes or No]
SECTION 1 : Notice to Bidders	
<ul style="list-style-type: none"> - Valid and original B-BBEE Verification Certificate or certified copy thereof [Large Enterprises and QSEs] Note: failure to provide a valid B-BBEE Verification Certificate at the closing date and time of the RFQ will result in an automatic score of zero for preference 	
<ul style="list-style-type: none"> - Valid and original B-BBEE certificate/sworn affidavit or certified copy thereof from auditor, accounting officer or SANAS accredited Verification Agency [EMEs] Note: failure to provide a valid B-BBEE Verification Certificate at the closing date and time of the RFQ will result in an automatic score of zero being allocated for preference 	
<ul style="list-style-type: none"> - In the case of Joint Ventures, a copy of the Joint Venture Agreement or written confirmation of the intention to enter into a Joint Venture Agreement 	
<ul style="list-style-type: none"> - Original valid Tax Clearance Certificate [Consortia / Joint Ventures must submit a separate Tax Clearance Certificate for each party] 	
SECTION 2 : Quotation Form	
SECTION 3: Vendor Application Form	
<ul style="list-style-type: none"> • Original cancelled cheque or bank verification of banking details 	
<ul style="list-style-type: none"> • Certified copies of IDs of shareholder/directors/members [as applicable] 	
<ul style="list-style-type: none"> • Certified copies of the relevant company registration documents from Companies and Intellectual Property Commission (CIPC) 	

Respondent's Signature _____

Date & Company Stamp _____

Returnable Documents	Submitted [Yes or No]
<ul style="list-style-type: none"> • Certified copies of the company's shareholding/director's portfolio 	
<ul style="list-style-type: none"> • Entity's letterhead 	
<ul style="list-style-type: none"> • Certified copy of VAT Registration Certificate [RSA entities only] 	
<ul style="list-style-type: none"> • Letter of Good Standing 	
<ul style="list-style-type: none"> • A Disposal Certificate must be submitted to Transnet by the future contractor 	

"PREVIEW COPY ONLY"

Respondent's Signature

Date & Company Stamp

Section 2
QUOTATION FORM

I/We _____
hereby offer to supply the goods/services at the prices quoted in the Price Schedule below, in accordance with the conditions related thereto.

I/We agree to be bound by those terms and conditions in:

- the Standard Terms and Conditions for the Supply of Goods or Services to Transnet [available on request]; and
- any other standard or special conditions mentioned and/or embodied in this Request for Quotation.

I/We accept that unless Transnet should otherwise decide and so inform me/us, this Quotation [and, if any, its covering letter and any subsequent exchange of correspondence], together with Transnet's acceptance thereof shall constitute a binding contract between Transnet and me/us.

I/We further agree that if, after I/we have been notified of the acceptance of my/our Quotation, I/we fail to deliver the said goods/service/s within the delivery lead-time quoted, Transnet may, without prejudice to any other legal remedy which it may have, cancel the order and recover from me/us any expenses incurred by Transnet in calling for Quotations afresh and/or having to accept any less favourable offer.

Price Schedule

I/We quote as follows for the goods required, on a "delivered nominated destination" basis, excluding VAT:

ONCE OFF AMOUNT	AMOUNT
REFURBISHMENT OF LAWN / GARDEN (once off amount)	

MONTHLY AMOUNT	AMOUNT
MONTHLY MAINTENANCE OF GARDEN (per month)	
REMOVAL OF DOMESTIC WASTE (per month)	
TOTAL AMOUNT (PER MONTH) FOR 1st YEAR	

Respondent's Signature

Date & Company Stamp

Bidders are obligated to supply the percentage breakdown of the presented price (this information is mandatory, failing to supply this information, your bid may be disqualified).

Consumables and Equipment portion to be based on CPI as at ruling date (contract inception date)

Labour portion to be based on the Statutory Labour increase as per government gazette at ruling date

Notes to Pricing:

- a) All Prices must be quoted in South African Rand, exclusive of VAT
- b) Please note that should you have offered a discounted price(s), Transnet will only consider such price discount(s) in the final evaluation stage if offered on an unconditional basis.

"PREVIEW COPY ONLY"

Respondent's Signature

Date & Company Stamp

Section 3

Vendor Application Form

"PREVIEW COPY ONLY"

Respondent's Signature

Date & Company Stamp



Transnet Supplier Declaration/Application

The Financial Director or Company Secretary

Transnet Vendor Management has received a request to load your company on to the Transnet vendor database. Please furnish us with the following to enable us to process this request:

1. Complete the "Supplier Declaration Form" (SDF) on page 2 of this letter
2. **Original** cancelled cheque **OR** letter from the bank verifying banking details (**with bank stamp**)
3. **Certified** copy of Identity document of Shareholders/Directors/Members (where applicable)
4. **Certified** copy of certificate of incorporation, CM29 / CM9 (name change)
5. **Certified** copy of share Certificates of Shareholders, CK1 / CK2 (if CC)
6. A letter with the company's letterhead confirming physical and postal addresses
7. **Original** or **certified** copy of SARS Tax Clearance certificate and Vat registration certificate
8. A signed letter from the Auditor / Accountant confirming most recent annual turnover and percentage black ownership in the company **AND/OR** BBBEE certificate and detailed scorecard from an accredited rating agency (SANAS member).

NB:

- **Failure to submit the above documentation will delay the vendor creation process.**
- *Where applicable, the respective Transnet business unit processing your application may request further information from you. E.g. proof of an existence of a Service/Business contract between your business and the respective Transnet business unit etc.*

IMPORTANT NOTES:

- a) **If your annual turnover is less than R5 million**, then in terms of the DTI codes, you are classified as an Exempted Micro Enterprise (EME). If your company is classified as an EME, please include in your submission, a signed letter from your Auditor / Accountant confirming your company's most recent annual turnover is less than R5 million and percentage of black ownership and black female ownership in the company **AND/OR** BBBEE certificate and detailed scorecard from an accredited rating agency (e.g. permanent SANAS Member), should you feel you will be able to attain a better BBBEE score.
- b) **If your annual turnover is between R5 million and R35million**, then in terms of the DTI codes, you are classified as a Qualifying Small Enterprise (QSE) and you claim a specific BBBEE level based on any 4 of the 7 elements of the BBBEE score-card, please include your BEE certificate in your submission as confirmation of your status.
NB: BBBEE certificate and detailed scorecard should be obtained from an accredited rating agency (e.g. permanent SANAS Member).
- c) **If your annual turnover is in excess of R35million**, then in terms of the DTI codes, you are classified as a Large Enterprise and you claim a specific BEE level based on all seven elements of the BBBEE generic score-card. Please include your BEE certificate in your submission as confirmation of your status.
NB: BBBEE certificate and detailed scorecard should be obtained from an accredited rating agency (permanent SANAS Member).
- d) **To avoid PAYE tax being automatically deducted from any invoices received from you**, you must also contact the Transnet person who lodged this request on your behalf, so as to be correctly classified in terms of Tax legislation.
- e) Unfortunately, **No payments can be made to a vendor** until the vendor has been registered, and no vendor can be registered until the vendor application form, together with its supporting documentation, has been received and processed.
- f) Please return the completed Supplier Declaration Form (SDF) together with the required supporting documents mentioned above to the Transnet Official who is intending to procure your company's services/products in order that he/she should complete and Internal Transnet Departmental Questionnaire before referring the matter to the appropriate Transnet Vendor Master Office.

Regards,

Transnet Vendor/Supplier Management .Contact person Carol tell: 021 940-3846 fax 021 940-3883.



Supplier Declaration Form

Company Trading Name							
Company Registered Name							
Company Registration Number Or ID Number If A Sole Proprietor							
Form of entity	CC	Trust	Pty Ltd	Limited	Partnership	Sole Proprietor	
VAT number (if registered)							
Company Telephone Number							
Company Fax Number							
Company E-Mail Address							
Company Website Address							
Bank Name				Bank Account Number			
Postal Address						Code	
Physical Address						Code	
Contact Person							
Designation							
Telephone							
Email							
Annual Turnover Range (Last Financial Year)		< R5 Million	R5-35 million	> R35 million			
Does Your Company Provide		Products	Services	Both			
Area Of Delivery		National	Provincial	Local			
Is Your Company A Public Or Private Entity		Public		Private			
Does Your Company Have A Tax Directive Or IRP30 Certificate		Yes		No			
Main Product Or Service Supplied (E.G.: Stationery/Consulting)							
BEE Ownership Details							
% Black Ownership	% Black women ownership	% Disabled person/s ownership					
Does your company have a BEE certificate		Yes		No			
What is your broad based BEE status (Level 1 to 9 / Unknown)							
How many personnel does the firm employ		Permanent		Part time			
Transnet Contact Person							
Contact number							
Transnet operating division							
Duly Authorised To Sign For And On Behalf Of Firm / Organisation							
Name		Designation					
Signature		Date					
Stamp And Signature Of Commissioner Of Oath							
Name		Date					
Signature		Telephone No.					

NB: Please return the completed Supplier Declaration Form (SDF) together with the required supporting documents mentioned above to the Transnet Official who is intending to procure your company's services/products.
 Transnet Vendor/Supplier Management .Contact person Carol tell: 021 940-3846 fax 021 940-3883

Section 3

STANDARD TERMS AND CONDITIONS FOR THE SUPPLY OF GOODS OR SERVICES TO TRANSNET

A Supplier/Service Provider shall be obliged to adhere to the Standard Terms and Conditions for the Supply of Goods and Services to Transnet as expressed hereunder. Should the Respondent find any condition(s) unacceptable, it should indicate which condition(s) is/are unacceptable and offer an alternative(s). A Quotation submitted by a Respondent will be subjected to review and acceptance or rejection of its proposed contractual terms and conditions by Transnet's Legal Counsel, prior to consideration for an award of business.

1 SOLE AGREEMENT

Unless otherwise agreed in writing, these terms [**Terms** and each **Term**] and Transnet's purchase order(s) [**Order** or **Orders**] represent the only conditions upon which Transnet SOC Ltd [**Transnet**] procures goods [**the Goods**] or services [**the Services**] specified in the Order from the person to whom the Order is addressed [**the Supplier/Service Provider**]. Transnet does not accept any other conditions which the Supplier/Service Provider may specify, unless otherwise agreed to by Transnet in writing. In the event of any inconsistency between these Terms and any Order, these Terms shall take precedence.

2 CONFORMITY WITH ORDER

Goods/Services shall conform strictly with the Order. The Supplier/Service Provider shall not vary the quantities specified and/or the specification, if any, stipulated in the Order, without the prior written consent of Transnet. The Supplier/Service Provider warrants that the Goods/Services shall be fit for their purpose and of satisfactory quality.

3 DELIVERY AND TITLE

- 3.1 The delivery dates and addresses are those in the Order. Time shall be of the essence in respect of the Supplier's/Service Provider's obligations under the Order.
- 3.2 The Supplier/Service Provider will not be excused for delay in delivery or performance except due to circumstances outside its control and then only subject to the Supplier/Service Provider having notified Transnet in writing on becoming aware of such circumstances. Transnet may terminate an Order, in whole or in part, without incurring any liability to the Supplier/Service Provider if such a delay becomes, in Transnet's absolute opinion, significant.
- 3.3 If on delivery, the Goods/Services do not conform to the Order, Transnet may reject the Goods/Services and the Supplier/Service Provider shall promptly rectify any defects or in Transnet's opinion, supply appropriate replacement Goods/Services at the Supplier's/Service Provider's expense within the specified delivery times, without any liability due by Transnet.

4 PRICE AND PAYMENT

- 4.1 Prices specified in an Order cannot be increased. Payment for the Goods/Services shall be made by Transnet against an original undisputed invoice(s) [a Tax Invoice], supporting documentation and month-end statement from the Supplier/Service Provider. Tax Invoices plus supporting documentation shall be posted to the address shown in the Order.

4.2 Payment of the Supplier's/Service Provider's valid Tax Invoice(s) will be made by Transnet in the South African currency and on the terms stated in the Order, the standard payment terms being 30 [thirty] days from date of receipt by Transnet of a month-end statement, unless otherwise agreed to in writing. Transnet shall arrange for payment of such Tax Invoices and any pre-authorised additional expenses incurred, provided that the authorised expenses are supported by acceptable documentary proof of expenditure incurred [where this is available]. Any amounts due in terms of these Terms shall be paid to the Supplier/Service Provider, taking into account any deduction or set-off and bank charges.

5 PROPRIETARY RIGHTS LIABILITY

If any allegations should be made or any claim asserted against Transnet that ownership of, or any act or omission by Transnet in relation to Goods/Services or any written material provided to Transnet relating to any Goods/Services or pursuant to an Order being a violation or infringement of any third party's contractual, industrial, commercial or intellectual property rights including but not limited to any patent, registered design, design right, trade mark, copyright or service mark on any application thereof, the Supplier/Service Provider hereby indemnifies Transnet against and holds it harmless from any and all losses, liabilities, costs, claims, damages and expenses [including any legal fees] arising directly or indirectly from such allegation or claim provided that this indemnity shall not apply where the allegation or claim arises solely as a result of the Supplier/Service Provider following a design or process originated and furnished by Transnet. The Supplier/Service Provider shall either

- a) procure for Transnet the right to continue using the infringing Goods; or
- b) modify or replace the Goods/Services so that they become non-infringing,

provided that in both cases the Goods/Services shall continue to meet Transnet's requirements and any specifications stipulated in the Order. Should neither option be possible, the Supplier/Service Provider may remove, with Transnet's prior written consent, such Goods/Services and will pay to Transnet a sum equivalent to the purchase price. If Transnet refuses to give such consent, the Supplier/Service Provider shall have no liability in respect of any continued use of the infringing Goods/Services after Supplier's/Service Provider's prior written request to remove the same.

6 PROPRIETARY INFORMATION

All information which Transnet has divulged or may divulge to the Supplier/Service Provider and any information relating to Transnet's business which may have come into the Supplier's/Service Provider's possession whilst carrying out an Order, and the existence of the Order, shall be treated by the Supplier/Service Provider as confidential information and shall not, without Transnet's prior written consent, be disclosed to any third party, or be used or copied for any purposes other than to perform the Order. This clause does not apply to information which is public knowledge or available from other sources other than by breach of this Term. Upon request by Transnet, the Supplier/Service Provider shall return all materials issued pursuant to the Order and, pending this, shall protect Transnet's rights in any such materials. Such confidential information shall at all material times be the property of Transnet.

7 PUBLICITY

The Supplier/Service Provider shall not name Transnet or use its trademarks, service marks [whether registered or not] or Goods in connection with any publicity without Transnet's prior written consent.

8 TERMINATION OF ORDER

- 8.1 Transnet may cancel an Order in whole or in part at any time upon at least 7 [seven] days' written notice to the Supplier/Service Provider, or when there is a change in control of the Supplier/Service Provider or the Supplier/Service Provider commits any serious breach or any repeated or continued material breach of its obligations under these Terms and/or Order or shall have been guilty of conduct tending to bring itself into disrepute, on written notice to the Supplier/Service Provider when such work on the Order shall stop.
- 8.2 Transnet shall pay the Supplier/Service Provider a fair and reasonable price for justified work in progress, where such price reflects only those costs not otherwise recoverable by the Supplier/Service Provider, at the time of termination, and the Supplier/Service Provider shall give Transnet full assistance to check the extent of such work in progress. Payment of such price shall be in full and final satisfaction of any claims arising out of such termination and upon such payment the Supplier/Service Provider shall deliver to Transnet all work, including any materials, completed or in progress. The sum payable to the Supplier/Service Provider under this clause will not in any event exceed the total amount that would have been payable to the Supplier/Service Provider had the Order not been terminated.
- 8.3 In the event of termination the Supplier/Service Provider must submit all claims within 2 [two] months of termination after which time claims will only be met in what Transnet considers exceptional circumstances.
- 8.4 If the Goods or Services are not provided in accordance with an Order, the Order shall be deemed terminated and the Supplier/Service Provider shall compensate Transnet for any costs incurred in obtaining substitute Goods or any damage caused due to the failure or delay in the delivery.

9 ACCESS

The Supplier/Service Provider shall be liable for the acts, omissions and defaults of its personnel or agents who, for the purposes of the Order, shall be treated as if they are the Supplier's/Service Provider's employees. The Supplier/Service Provider shall ensure that any such personnel or agents, whilst on Transnet's premises, shall comply with Transnet's health and safety, security and system security rules and procedures as and where required.

10 WARRANTY

The Supplier/Service Provider warrants that it is competent to supply the Services in accordance with these Terms to the reasonable satisfaction of Transnet and that all Services delivered under the Order: (a) conform and comply in all relevant legislation, standards, directives and orders related to [*inter alia*] the Services in force at the time of delivery, and to any specifications referred to in the Order; (b) will not cause any deterioration in the functionality of any Transnet equipment; and (c) do not infringe any third party rights of any kind. The Supplier/Service Provider hereby indemnifies Transnet against all losses, liabilities, costs, claims, damages, expenses and awards of any kinds incurred or made against Transnet in connection with any breach of this warranty.

11 INSOLVENCY

If the Supplier/Service Provider shall have a receiver, manager, administrator, liquidator or like person appointed over all or any part of its assets or if the Supplier/Service Provider compounds with its creditors or passes a resolution for the writing up or administration of the Supplier/Service Provider, Transnet is at liberty to terminate the Order or Orders forthwith, or at its option, to seek performance by any such appointed person.

12 ASSIGNMENT

The Supplier/Service Provider shall not assign its obligations under an Order without Transnet's prior written consent, which consent shall not be unreasonably withheld or delayed.

13 NOTICES

Notices under these Terms shall be delivered by hand to the relevant addresses of the parties in the Order or may be served by facsimile or by email, in which event notice shall be deemed served on acknowledgement of receipt by the recipient.

14 LAW

Orders shall be governed by and interpreted in accordance with South African law and any disputes arising herein shall be subject to South African arbitration under the rules of the Arbitration Foundation of South Africa, which rules are deemed incorporated by reference in this clause. The reference to arbitration shall not prevent Transnet referring the matter to any South African courts, having jurisdiction, to which the Supplier/Service Provider hereby irrevocably submits but without prejudice to Transnet's right to take proceedings against the Supplier/Service Provider in other jurisdictions and/or obtaining interim relief on an urgent basis from a court of competent jurisdiction pending the decision in other courts or from instituting in any court of competent jurisdiction any proceedings for an interdict or any other injunctive relief. If the Supplier/Service Provider does not have a registered office in the South Africa it will at all times maintain an agent for service of process in South Africa and shall give Transnet the name and address of such agent as such may be amended in writing, from time to time.

15 GENERAL

Completion or termination of an Order shall be without prejudice to any Term herein which by its nature would be deemed to continue after completion or termination. Headings are included herein for convenience only. If any Term herein be held illegal or unenforceable, the validity or enforceability of the remaining Terms shall not be affected. No failure or delay by Transnet to enforce any rights under these Terms will operate as a waiver thereof by Transnet. All rights and remedies available to either party under these Terms shall be in addition to, not to the exclusion of, rights otherwise available at law.

16 COUNTERPARTS

These Terms and conditions may be signed in any number of counterparts, all of which taken together shall constitute one and the same instrument. Any party may enter into this agreement by signing any such counterpart.

By signing this RFQ document, the Respondent is deemed to acknowledge that he/she has made himself/herself thoroughly familiar with all the conditions governing this RFQ, including those contained in any printed form stated to form part hereof and Transnet SOC Ltd will recognise no claim for relief based on an allegation that the Respondent overlooked any such condition or failed to properly take it into account for the purpose of calculating quoted prices or otherwise.

SIGNED at _____ on this ____ day of _____ 20__

.....
SIGNATURE OF RESPONDENT'S AUTHORISED REPRESENTATIVE

NAME: _____

DESIGNATION: _____

REGISTERED NAME OF COMPANY: _____

PHYSICAL ADDRESS:

Respondent's contact person: *[Please complete]*

Name :
Designation :
Telephone :
Cell Phone :
Facsimile :
Email :
Website :

**Transnet urges its clients, suppliers and the general public
to report any fraud or corruption to
TIP-OFFS ANONYMOUS : 0800 003 056**

Section 4: CERTIFICATE OF ACQUAINTANCE WITH SPECIFICATIONS

I/We

_____ do hereby certify that I/we acquainted myself/ourselves with all the documentation comprising the Specifications for the carrying out of the proposed Services for which I/we submitted my/our Proposal.

I/We furthermore agree that Transnet SOC Ltd shall recognise no claim from me/us for relief based on an allegation that I/we overlooked any provisions of the Specifications or failed to take it into account for the purpose of calculating my/our offered prices or otherwise.

I/We confirm having been advised that a signed copy of this Schedule can be submitted in lieu of the Specifications as confirmation in terms of the Returnable Schedule.

SIGNED at _____ on this _____ day of _____ 20_____

SIGNATURE OF WITNESS

SIGNATURE OF RESPONDENT

"PREVIEW COPY ONLY"

Section 5:

CERTIFICATE OF ATTENDANCE OF SITE BRIEFING – RFQ SAZ52744

It is hereby certified that –

1. _____

2. _____

Representative(s) of _____ [name of entity]

attended the RFP briefing in respect of the proposed Services to be rendered in terms of this RFP on

_____ 20____

TRANSNET'S REPRESENTATIVE

RESPONDENT'S REPRESENTATIVE

DATE _____

DATE _____

EMAIL _____

"PREVIEW COPY ONLY"

ANNEXURE A

PROJECT SPECIFICATIONS

SAZ52744

MAINTENANCE OF GARDENS AND GROUNDS AT TRANSNET FREIGHT RAIL HALFWEG (Loop 10)

1. **SCOPE OF WORK**

The work includes the monthly maintenance of gardens, lawn areas, flower beds and open areas of Transnet in the vicinity of Halfweg.

2. **LAWN**

The regular mowing of lawn and trimming of grass borders according to standards laid down.

3. **FLOWER BEDS**

The regular cleaning and keeping clean of flower beds according to standards laid down.

4. **OPEN AREAS**

The twice monthly maintenance and cleaning of open areas/parking areas according to the standards laid down.

Area to be Cleared in m² is as follows (see attached plan):-

Bottom Hostel area = 8317m²

Main hostel area = 17408m²

5. **REQUIREMENTS FOR THE CONTRACT**

LAWS AND REGULATIONS

The Workmen's Compensation Act 1941 (as amended).

Basic Conditions of Employment Act (Act No. 3 of 1983) (as amended).

Provincial Ordinances and Local Authority By-laws, and all relevant Regulations framed there under.

Basic Conditions of Employment Act.

Environmental Conservation Act, 1989 (Act 73 of 1989).

Occupational Health and Safety Act (Act 85 of 1993 and Regulations).

Code of Practice No. 29 for the safe operation of machinery, plant and equipment.

6. **EQUIPMENT AND MACHINERY**

The Contractor shall provide all tools and equipment required to perform the work. All equipment and machinery that will be used in the execution of the contract must comply to the safety standards as requires in Act 85 of 1993 and Regulations to the Act. Internal combustion engines that cause excessive smoke or noise will not be allowed. Safety clothes/equipment must be provided by the contractor who shall ensure that his staff wear same at all times. The Contractor must issue his staff with protective clothing.

7. **STANDARD OF WORK**

LAWN

The lawns shall be cut twice monthly and the edges trimmed to prevent ingress growth into the flower beds.

Weeds shall also be removed from the lawn areas. Where necessary a top dressing should be applied and the suitable application of fertiliser to ensure a healthy and green lawn area.

FLOWER BEDS

Flower beds must be kept tidy and weed free at all times. Maintenance of flower beds must be done on twice monthly basis. All garden waste shall be removed simultaneously by the contractor. Weed killer shall not be used in flower beds.

TREES

Trees shall be trimmed at regular intervals and kept neat at all times.

OPEN AREAS/PARKING AREAS/ WALKWAYS

All open ground and parking areas shall be kept free of weeds , rubbish and stones at all times. Weed killer shall be applied when necessary to ensure a weed-free area. Parking areas shall be swept clean on the same day that the lawns are cut.

REMOVAL OF GARDEN WASTE

All garden waste, lawn cuttings, etc. must be removed each time from the maintenance area. The Contractor shall provide transport and labour for the removal of this garden waste.

WATERING/AFTER CARE OF LAWN AND FLOWER BEDS

The contractor shall water the lawn areas and flower beds on the same days that the refuse is collected from the hostels – twice weekly.

REFURBISHMENT OF EXISTING LAWN AREA / GARDEN

Here the contractor is required to create a new garden or a revamp of the existing garden. Water wise plants or shrubs shall be utilised that are suitable for the area.

The soil has to be prepared by loosening and removing roots and stones from the area. Compost and superphosphate is to be added to the soil and worked through. Once the soil has been levelled the lawn may be laid. Buffalo lawn is preferred.

The area will be indicated by the Project Manager and the final shape of the lawn will be discussed.

REQUIREMENTS FOR REFURBISHMENT

Buffalo (preferred) or Kikuyu lawn (roll on lawn)

Kraggroie – compost

Superphosphate or similar initially and an appropriate fertilizer thereafter as and when required.

8. GENERAL

Lawn shall where possible be watered by means of garden hoses with sprinklers (rotating impact sprinklers "rain bird", or similar). Where not applicable, lawn shall be watered by hand. The Contractor shall provide his own garden hoses and sprinklers and other equipment required for this purpose.

The Contractor will be held responsible for any damages or losses caused by himself or any of his employees to Transnet property as well as any third party and will indemnify Transnet against any claims that may arise as a result of the aforementioned.

If the Contractor suffers delay to meet any of the contract conditions or specifications, or delivers work of a poor quality, or fails to rectify work as requested by Transnet within a period of seven (7) days, Transnet shall have the right to cancel the contract without any further shall notice to the contractor.

The Contractor must subject himself to the security requirements of Transnet.

Any deviation of the above-mentioned clauses or omitting to use the machinery/safety equipment as specified may result in the deduction of a twenty percent (20 %) penalty, from the monthly payment.

9. **WORKING METHODS**

The Contractor must give a description of the working methods that she/he will follow to meet with the Contract Specifications. It includes the following:

- 9.1 Day to day work program - where and what will be done (in conjunction with refuse removal)
- 9.2 Contractors inspection - Times and dates
- 9.3 Number of days that the employees of the Contractor will be continuously on site.
- 9.4 Any additional services that the Contractor can produce in the execution of the contract.
- 9.5 Whether the Contractor will make use of weed killers in which instance he/she shall use the necessary protective equipment / clothing.

10. **AS AND WHEN REQUIRED**

The contractor must be available for "as and when" maintenance on the gardens for the duration of the 24 month contract period. The Project Manager shall liaise with the contractor in this regard whenever such need shall arise and separate quotations will be required to be submitted in each instance.

"PREVIEW COPY ONLY"

Annexure B

PROJECT SPECIFICATIONS

SAZ52744

REMOVAL OF DOMESTIC WASTE FROM TRANSNET FREIGHT RAIL AT HALFWEG (Loop 10)

1. The work includes the removal of all domestic waste from the two (2) Hostels and the surrounding houses.
2. The domestic waste must be taken to the nearest Town's waste dump where the waste must be disposed of. (Nearest town is Brandtville which is situated approx 80km's from Halfweg).
3. The removal of the waste must be undertaken **twice a Week from the two (2) Hostels and once (1) a week from the houses.**
4. There are ten (10) houses adjacent to the Bottom Hostel and seven (7) houses adjacent to the Top Hostel.
5. The 17 houses generate approx 2040 kg of domestic waste per week.
6. The two hostels generate approx 9000 kg's of domestic waste per week.
7. Total waste for hostels and houses is approx 11000 kg's per week.
8. A Disposal Certificate must be submitted to Transnet by the contractor simultaneously with each monthly invoice.

ANNEXURE C

SPECIAL CONDITIONS

RFQ SAZ52744

**GARDENING SERVICES AND REMOVAL OF DOMESTIC WASTE AT
HALFWEG**

1 Scope of work

Gardening services and removal of domestic waste at Halfweg

2. Site location

The site is situated at Halfweg (Loop 10).

3. Time to complete the work

Failing completion of the work within the period as stipulated the contractor shall pay to Transnet the sum of R500.00 for every day or part thereof during which the works remain incomplete.

4. Guarantee

N / a

5. Inspection of works

5.1 No work shall be covered up or put out of view without the approval of the Project Manager. The Contractor shall afford full opportunity for the Project Manager to examine and measure any work, which is about to be covered up or put out of view and to examine foundations before permanent work is placed thereon.

5.2 The Contractor shall uncover any part or parts of the work or make openings in or through the same as the Project Manager may from time to time direct and shall reinstate and make good such part or parts to the satisfaction of the Project Manager and are found to be executed in accordance with the Contract, the expenses of uncovering, making openings in or through, reinstating and making good the same shall be done by the Contractor .

"PREVIEW COPY ONLY"

6. **Site records**

6.1 **Site Instruction Book**

The Contractor shall provide a **site instruction book, in triplicate for the Project Manager to place all instructions** that are needed to compliment the specifications and drawings and any other instruction that may affect the cost of the work.

No work will be recognized for additional payment unless it has been recorded and signed by the Project Manager in the aforesaid book.

6.2 **Site Diary**

The contractor shall provide a diary, in triplicate to record all day to day incidents that could occur during the contract period. This includes weather, names & numbers of workers on site, material that has been delivered, material that has been loaded and disposed off, incidents that have occurred, nature of work to be done on that day, etc.

7. **Access to site**

The areas are restricted and the contractor must ensure he complies with the regulations of Transnet Freight Rail in every way. The Contractor and/or any sub-contractors shall be required to apply for permission to enter the restricted area in writing. A list of workmen shall be given to the Project Manager to arrange for the necessary permits. 48 Hours minimum notice is necessary for the processing these permits. This includes changes to staff during the contract period.

8. **To be supplied by the Contractor**

The Contractor shall provide all labour, transport, consumable stores, plant, equipment, tools, services, materials and ingredients of every description required for the carrying out and completion of the WORKS as per this specification and as may be ordered by the Manager.

9. **Site meetings**

The Contractor shall be called upon to attend meetings on the site to discuss the progress of WORKS with the Transnet Freight Rail representatives / Project Manager.

10. **Substance abuse testing**

The OHSA (Act 85 of 1993) clearly states in the Safety Regulations 2A **“INTOXICATION” An employer or user, as the case may be, shall not permit any person who appears to be under the influence of intoxicating liquor or drugs, to enter or remain at a workplace.** Transnet Freight Rail enforces this legislation by means of its Substance Abuse Policy, and therefore reserves the right to do substance abuse testing on anyone who enters their premises.

SconSAZ52744

“PREVIEW COPY ONLY”



Plan prepared for:
TRANSNET FREIGHT RAIL
PROPERTY MANAGEMENT
 Silver Building
 SALDANHA

Contact person: Mr. Kelvin Ledwys
 Tel: (021) 7033204

LEGEND:

-  TRANSNET OWNED LAND
-  AREA TO BE CLEANED: ± 4 613 m²
-  AREA TO BE TREATED WITH WEED KILLER: ± 6 715 m²

GEOGRAPHIC CO-ORDINATE (WGS84)

Pt.	LAT:	LONG:
A	30° 01' 09.47" S	20° 07' 55.47" E



Plan prepared by:
TRANSNET
 GEO-SPATIAL: WESTERN REGION, TRANSNET PROPERTY
 PO Box 4733
 Cape Town
 801

HALFWEG
MAINTENANCE PLAN

PLAN SHOWING AREAS ALLOCATED FOR
 CLEANING/MAINTENANCE

Completed:	Checked:	Client File Ref.:
S.S.	B.A.S.	GS File No.:
Date:	Original Ref.:	R.A.V.E.
2013-05-09	SCALE : 1 / 1 000	

Rev. -
PLAN No. LSL 0012m

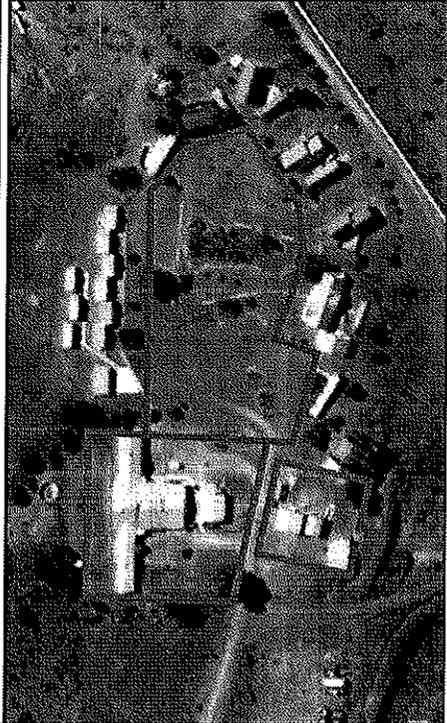
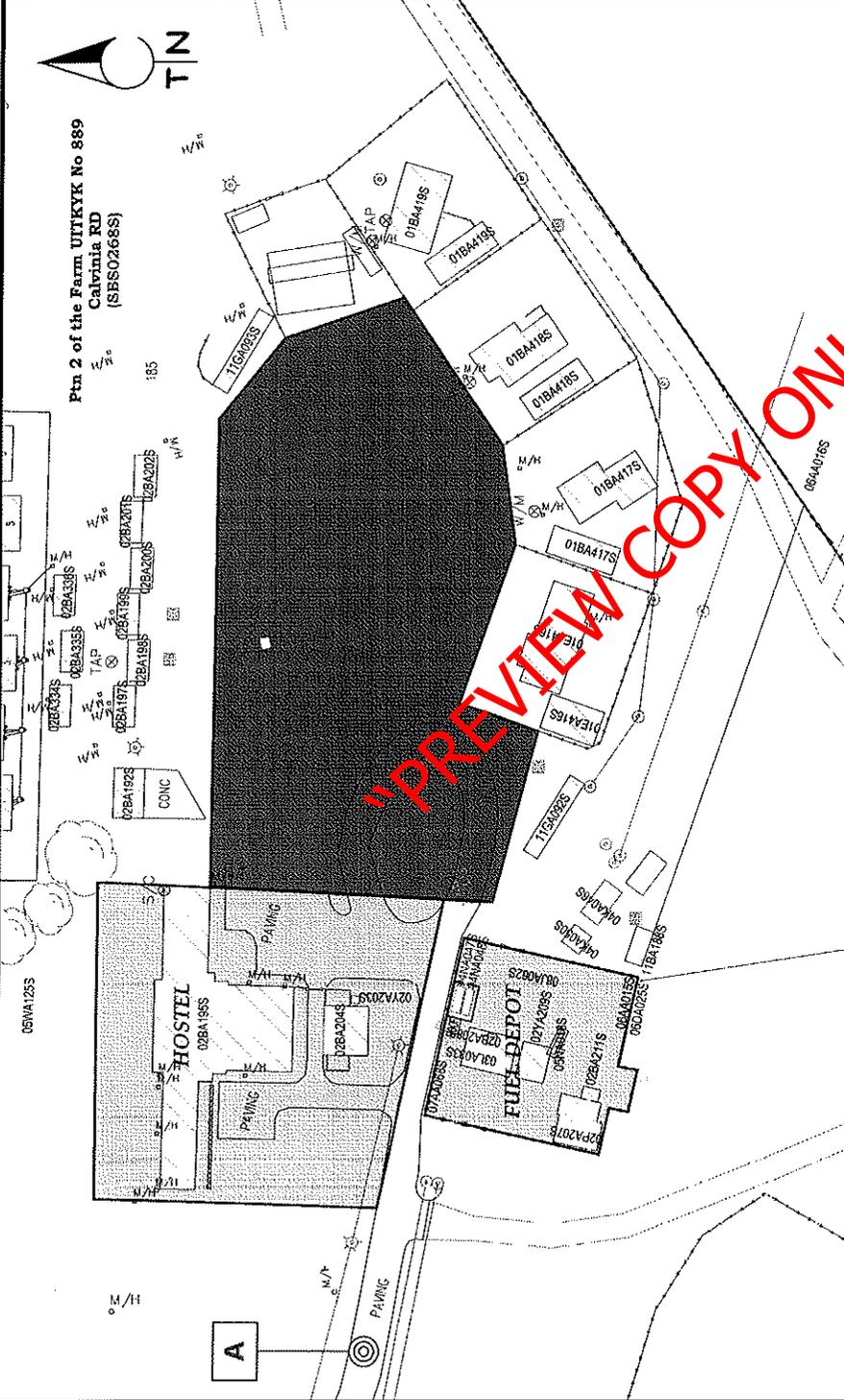

"PREVIEW COPY ONLY"

AERIAL PHOTO SCALE: 1 / 2 000
LOCALITY PLAN SCALE: 1 / 75 000
PLAN No. LSL 0012m

Plan prepared by:
TRANSNET
 TRANSNET FREIGHT RAIL
 PROPERTY MANAGEMENT
 Silar Building
 SALDANHA

Freight-rail

Contact person: Mr. Keith Lodgek
 Tel: (022) 70343304

LEGEND:

TRANSNET OWNED LAND

AREA TO BE CLEANED: ± 388 m²

GEOGRAPHIC CO-ORDINATE (WGS84)

Pt.	LAT:	LONG:
A	30° 01' 04.13" S	20° 07' 52.27" E

TRANSNET

Plan prepared by:
 GEO-SPATIAL: WESTERN REGION, TRANSNET PROPERTY
 No. 1, Ave. de Smet
 DUNE TOWN
 6010

Tel: (021) 440-4484
 Fax: (021) 440-4311
 e-mail: gsp@transnet.co.za

HALFWEG

MAINTENANCE PLAN

PLAN SHOWING AREAS ALLOCATED FOR
 CLEANING/MAINTENANCE

Completed:	Checked:	Client File Ref.:
S.S.	B.A.S.	G.S. File Ref.:
Date:	2013-05-09	Original Ref.:
Rev.:		R.A.V.E.
		SCALE : 1 / 1 000

PLAN No. **LSL 0013m**

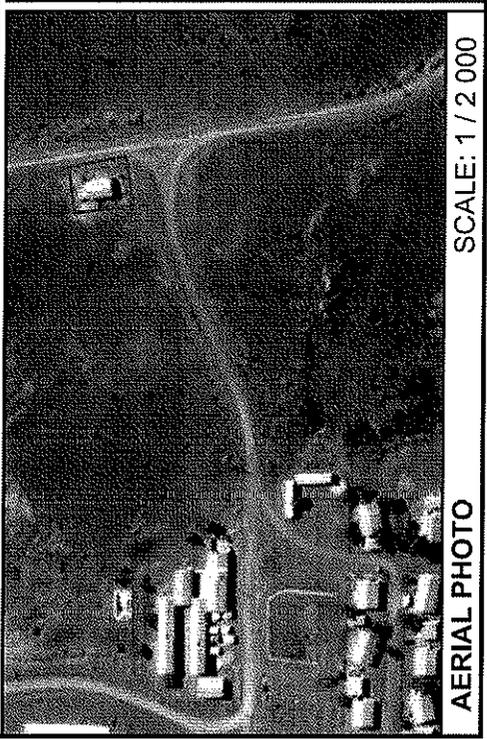
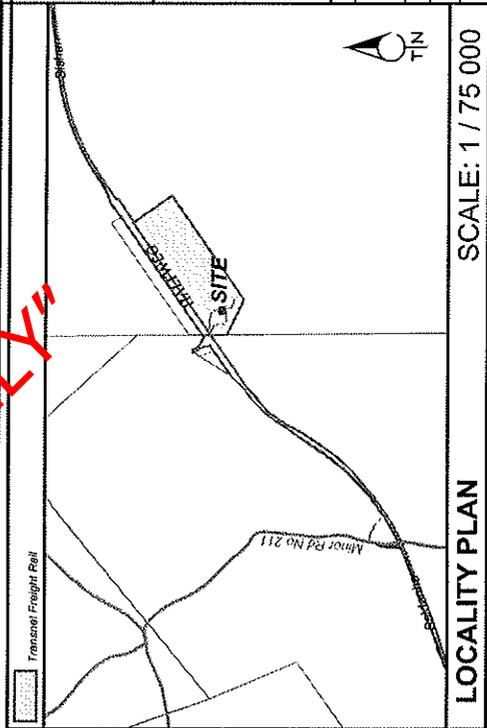
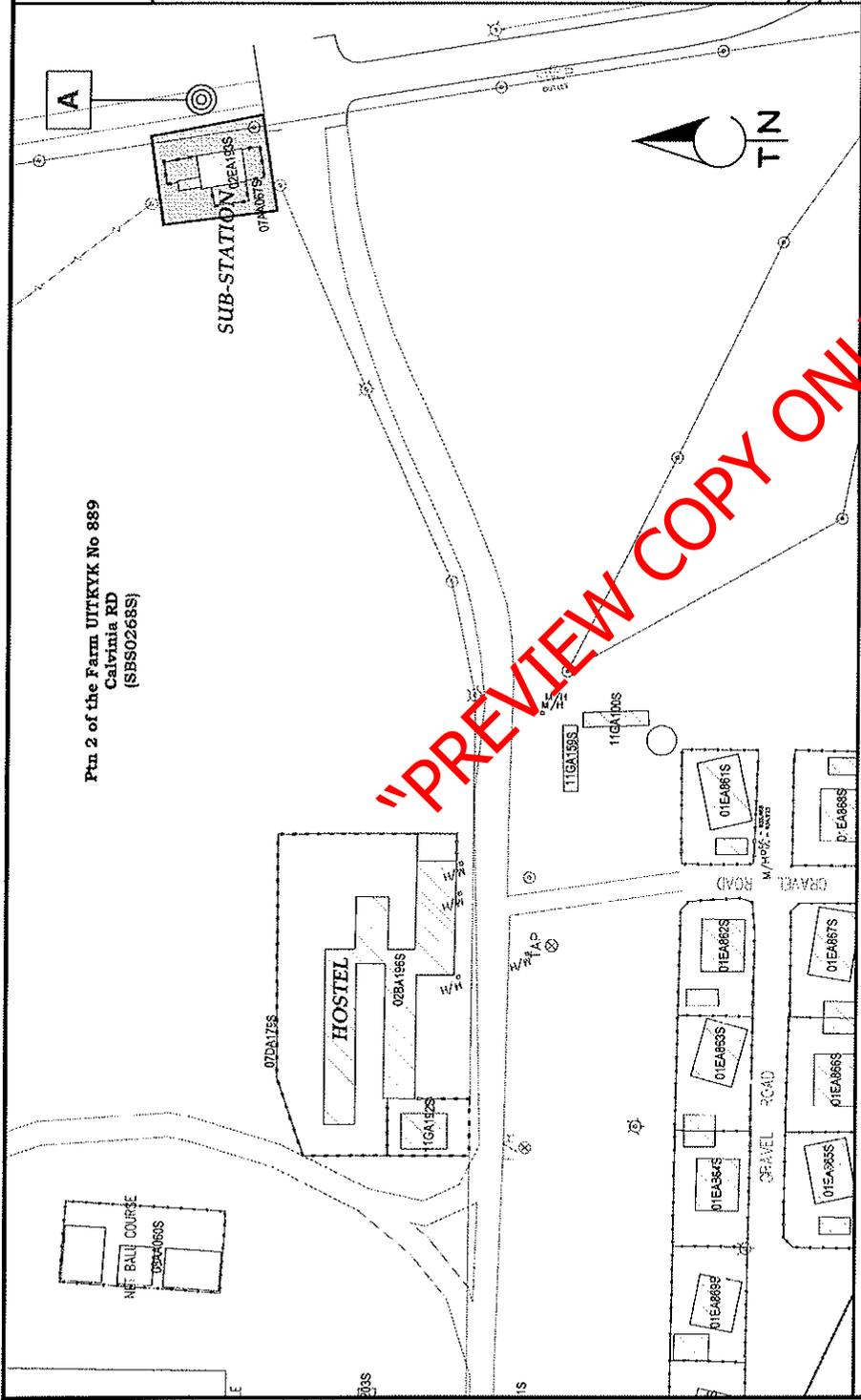

AERIAL PHOTO SCALE: 1 / 2 000

LOCALITY PLAN SCALE: 1 / 75 000

PLAN No. LSL 0013m



 Plan prepared for:
TRANSNET FREIGHT RAIL
 PROPERTY MANAGEMENT
 Salford Building
 SALDANHA

 Contact person: Mr. Keith Ludowyk
 Tel: (022) 703-3304

LEGEND:

 TRANSNET OWNED LAND
 AREA TO BE CLEANED: ± 7 929 m²

GEOGRAPHIC CO-ORDINATE (WGS84)

Pt.	LAT.	LONG.
A	30° 01' 05.65" S	20° 07' 43.68" E



TRANSNET
 Plan prepared by:
 GEO-SPATIAL WESTERN REGION, TRANSNET PROPERTY
 Room 205
 1 Academy Street
 CAPETOWN
 8001
 Tel: (021) 149-0311
 Fax: (021) 149-0311
 email: gsp@transnet.co.za

HALFWEG
MAINTENANCE PLAN
 PLAN SHOWING AREAS ALLOCATED FOR
 CLEANING/MAINTENANCE

Completed:	Checked:	Client File Ref.:
S.S.	B.A.S.	GS File Ref.:
Date:	2013-05-09	Original Ref.:
Rev.:		R.A.V.E.
		SCALE : 1 / 1 000
		PLAN No. LSL 0010m

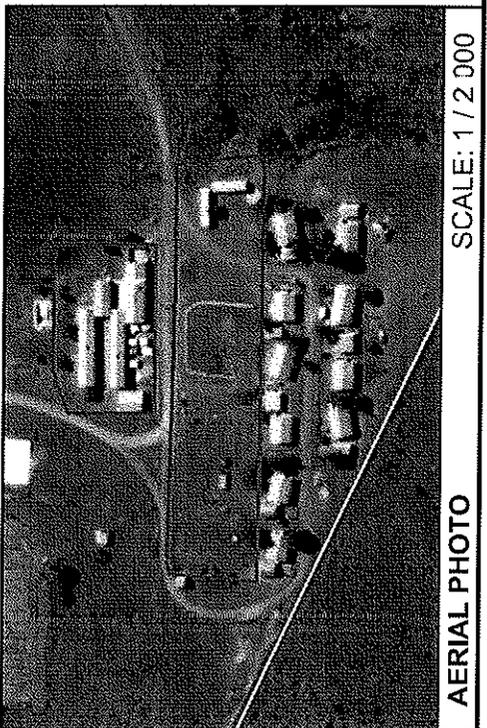
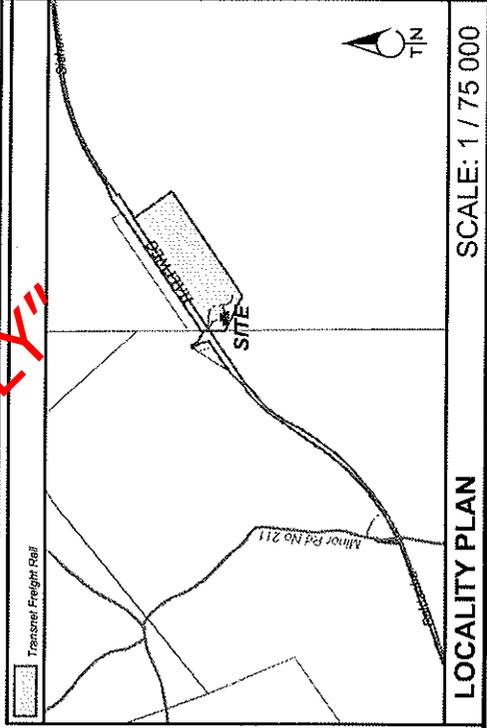
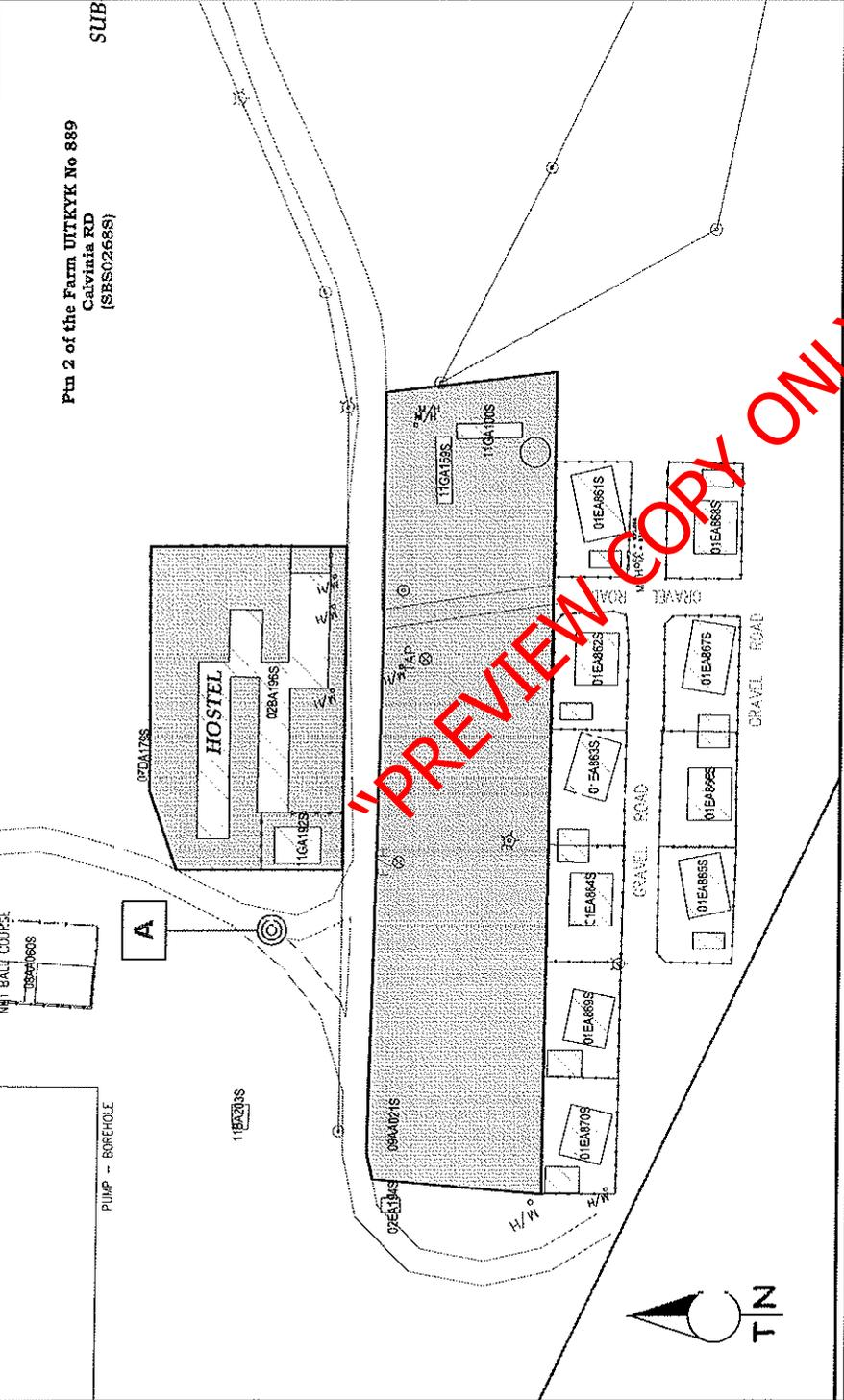

TRANSNET
 Plan prepared for:
 TRANSNET FREIGHT RAIL
 PROPERTY MANAGEMENT
 Sakhar Building
 SALDANHA

Contract person: Mr. Keith Ludowyk
 Tel: (022) 732-5304

LEGEND:

TRANSNET OWNED LAND

AREA TO BE CLEANED: ± 6 080 m²

TRANSNET
 GEO-SPATIAL: WESTERN REGION, TRANSNET PROPERTY
 Room 205
 10 BAK 4753
 Cape Town
 Tel: (021) 464-484
 Fax: (021) 464-431
 gis@transnet.co.za

HALFWEG
 MAINTENANCE PLAN
 PLAN SHOWING AREAS ALLOCATED FOR
 CLEANING/MAINTENANCE

Compiled: S.S. B.A.S. Date: 2013-05-09
 Checked: Client File Ref. GS File Ref. Original Ref. R.A.V.E.
 Scale: 1 / 1 000

GEOGRAPHIC CO-ORDINATE (WGS84)

Pt:	LAT:	LONG:
A	30° 01' 09.72" S	20° 07' 58.03" E

TRANSNET

Plan prepared for:
 TRANSNET FREIGHT RAIL
 PROPERTY MANAGEMENT
 Sakhar Building
 SALDANHA

Contract person: Mr. Keith Ludowyk
 Tel: (022) 732-5304

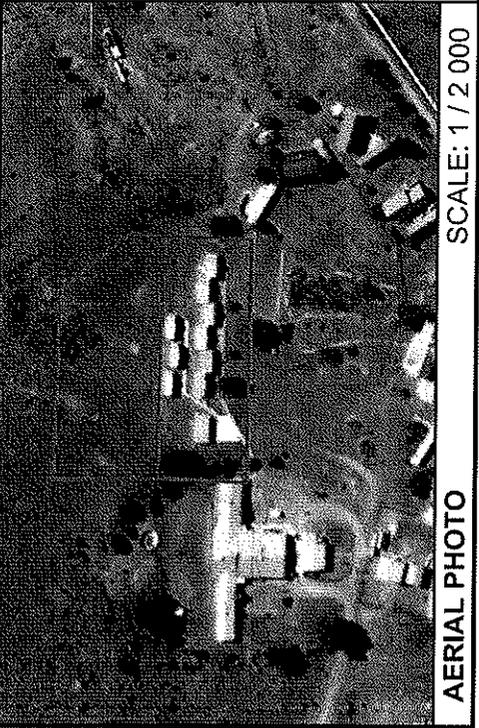
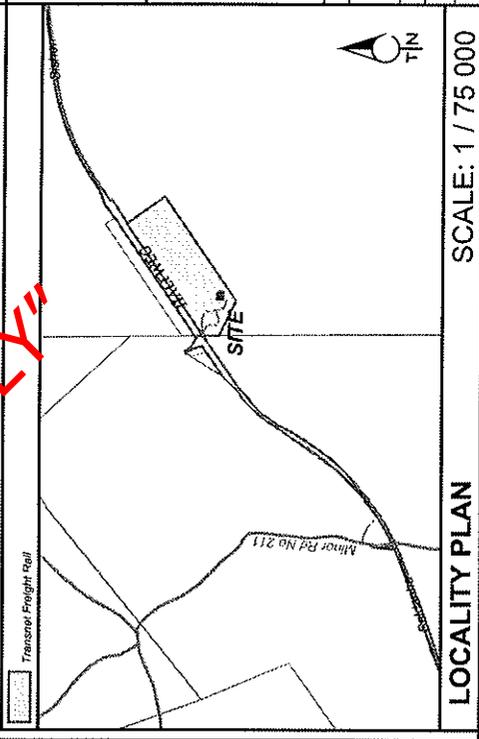
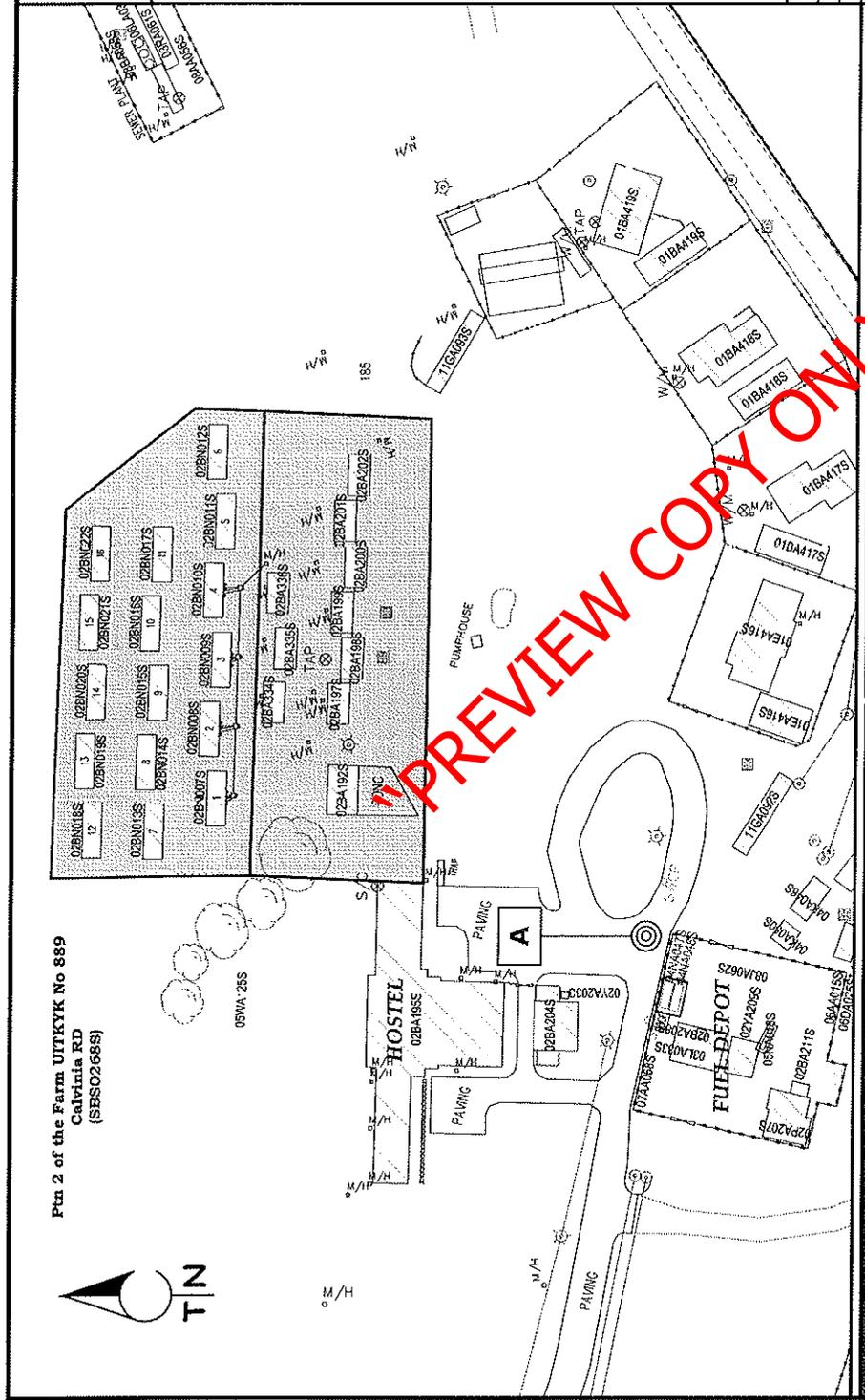

SCALE: 1 / 75 000

LOCALITY PLAN

SCALE: 1 / 2 000

AERIAL PHOTO

PLAN No. **LSL 0011m**

TRANSNET

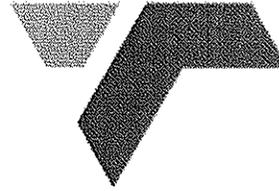

Transnet SOC Limited Registration Number 1990/00900/30

TRANSNET SPECIFICATION

E7/1 - SPECIFICATION FOR GENERAL WORK AND WORKS ON, OVER, UNDER OR ADJACENT TO RAILWAY LINES AND NEAR HIGH VOLTAGE EQUIPMENT

(This specification shall be used in network operator contracts)

"PREVIEW COPY ONLY"

Circulation Not Restricted

© This document as a whole is protected by copyright. The information herein is the sole property of Transnet SOC Ltd. It may not be used, disclosed or reproduced in part or in whole in any manner whatsoever, except with the written permission of and in a manner permitted by the proprietors.

(This page not to be issued with contract)

CONTENTS

<u>CLAUSE</u>	<u>HEADING</u>	<u>PAGE</u>
1.0	SCOPE	3
2.0	DEFINITIONS	3
PART A - GENERAL SPECIFICATION		
3.0	AUTHORITY OF OFFICERS OF TRANSNET	4
4.0	CONTRACTOR'S REPRESENTATIVES AND STAFF	4
5.0	OCCUPATIONS AND WORK PERMITS	4
6.0	SPEED RESTRICTIONS AND PROTECTION	5
7.0	ROADS ON THE NETWORK OPERATOR'S PROPERTY	5
8.0	CLEARANCES	5
9.0	STACKING OF MATERIAL	5
10.0	EXCAVATION, SHORING, DEWATERING AND DRAINAGE	5
11.0	FALSEWORK FOR STRUCTURES	6
12.0	PILING	6
13.0	UNDERGROUND SERVICES	6
14.0	BLASTING AND USE OF EXPLOSIVES	6
15.0	RAIL TROLLEYS	7
16.0	SIGNAL TRACK CIRCUITS	7
17.0	PENALTY FOR DELAYS TO TRAINS	7
18.0	SURVEY BEACONS AND PEGS	7
19.0	TEMPORARY LEVEL CROSSINGS	8
20.0	COMPLETION OF THE WORKS	8
21.0	PROTECTION OF PERSONS AND PROPERTY	9
22.0	INTERFERENCE WITH THE NETWORK OPERATOR'S ASSETS AND WORK ON OPEN LINES	10
23.0	ACCESS, RIGHTS-OF-WAY AND CAMPSITES	10
24.0	SUPERVISION	10
25.0	HOUSING OF EMPLOYEES	10
26.0	OPTICAL FIBRE CABLE ROUTES	10
PART B - ADDITIONAL SPECIFICATION FOR WORK NEAR HIGH-VOLTAGE ELECTRICAL EQUIPMENT		
27.0	GENERAL	11
28.0	WORK ON BUILDINGS OR FIXED STRUCTURES	11
29.0	WORK DONE ON OR OUTSIDE OF ROLLING STOCK, INCLUDING LOADING AND UNLOADING	11
30.0	USE OF EQUIPMENT	12
31.0	CARRYING AND HANDLING MATERIAL AND EQUIPMENT	12
32.0	PRECAUTIONS TO BE TAKEN WHEN ERECTING OR REMOVING POLES, ANTENNAE AND TREES ETC.	12
33.0	USE OF WATER	13
34.0	USE OF CONSTRUCTION PLANT	13
35.0	WORK PERFORMED UNDER DEAD CONDITIONS UNDER COVER OF A WORK PERMIT	13
36.0	TRACTION RETURN CIRCUITS IN RAILS	13
37.0	HIGH-VOLTAGE ELECTRICAL EQUIPMENT NOT MAINTAINED AND/OR OPERATED BY THE NETWORK OPERATOR	14

1.0 SCOPE

- 1.1 This specification covers the network operator's requirements for general work and works on, over, under or adjacent to railway lines and near high voltage equipment.

2.0 DEFINITIONS

The following definitions shall apply:

"Authorised Person" - A person whether an employee of the network operator or not, who has been specially authorised to undertake specific duties in terms of Transnet's publication Electrical Safety Instructions, and who holds a certificate or letter of authority to that effect.

"Barrier" Any device designed to restrict access to "live" high-voltage electrical equipment.

"Bond" - A short conductor installed to provide electrical continuity.

"Contractor" - Any person or organisation appointed by the network operator to carry out work on its behalf.

"Contract Supervisor" - The person or juristic person appointed by the network operator from time to time as the Contract Supervisor, to administer the Contractor's performance and execution of the Works according to the powers and rights held by and obligations placed upon the Contract Supervisor in terms of the Contract.

"Dead" - Isolated and earthed.

"Electrical Officer (Contracts)" - The person appointed in writing by the Project Manager in terms of this specification as the person who shall be consulted by the Contractor in all electrical matters to ensure that adequate safety precautions are taken by the Contractor.

"Executive Officer" - The person appointed by the network operator from time to time as the Executive Officer to act according to the rights and powers held by and obligations placed upon him in terms of the Contract.

"High-Voltage" - A voltage normally exceeding 1000 volts.

"Live" - A conductor is said to be "live" when it is at a potential different from that of the earth or any other conductor of the system of which it forms a part.

"Near" - To be in such a position that a person's body or the tools he is using or any equipment he is handling may come within 3 metres of "live" exposed high-voltage electrical equipment.

"Occupation" - An authorisation granted by the network operator for work to be carried out under specified conditions on, over, under or adjacent to railway lines.

"Occupation Between Trains" - An occupation during an interval between successive trains.

"Optical Fibre Cable" - Buried or suspended composite cable containing optical fibres used in:

- telecommunication networks for transmission of digital information and
- safety sensitive train operations systems.

"Project Manager" - As defined in the special conditions of the contract. The person or juristic person appointed by the network operator from time to time as the Project Manager, to administer the Contract according to the powers and rights held by and obligations placed upon him in terms of the Contract.

"Responsible Representative" - The responsible person in charge, appointed by a contractor, who has undergone specific training (and holds a certificate) to supervise (general or direct) staff under his control who perform general work or to work on, over, under or adjacent to railway lines and in the vicinity of high-voltage electrical equipment.

"Total Occupation" - An occupation for a period when trains are not to traverse the section of line covered by the occupation.

"Work on" - Work undertaken on or so close to the equipment that the specified working clearances to the "live" equipment cannot be maintained.

"Work Permit" - A combined written application and authority to proceed with work on or near dead electrical equipment.

"Works" - The contractual intent for the work to be done as defined in the contract at a defined work site.

PART A - GENERAL SPECIFICATION**3.0 AUTHORITY OF OFFICERS OF TRANSNET**

- 3.1 The Contractor shall co-operate with the officers of the network operator and shall comply with all instructions issued and restrictions imposed with respect to the Works which bear on the existence and operation of the network operator's railway lines and high-voltage equipment.
- 3.2 Without limiting the generality of the provisions of clause 3.1, any duly authorised representative of the network operator, having identified himself, may stop the work if, in his opinion, the safe passage of trains or the safety of the network operator's assets or any person is affected. **CONSIDERATIONS OF SAFETY SHALL TAKE PRECEDENCE OVER ALL OTHER CONSIDERATIONS.**

4.0 CONTRACTOR'S REPRESENTATIVES AND STAFF

- 4.1 The Contractor shall nominate Responsible Representatives of whom at least one shall be available at any hour for call-out in cases of emergency. The Contractor shall provide the Contract Supervisor with the names, addresses and telephone numbers of the representatives.
- 4.2 The Contractor guarantees that he has satisfied himself that the Responsible Representative is fully conversant with this specification and that he shall comply with all his obligations in respect thereof.
- 4.3 The Contractor shall ensure that all contractor staff receives relevant awareness, educational and competence training regarding safety as prescribed.

5.0 OCCUPATIONS AND WORK PERMITS

- 5.1 Work to be done during total occupation or during an occupation between trains or under a work permit shall be done in a manner decided by the Contract Supervisor and at times to suit the network operator requirements.
- 5.2 The Contractor shall organise the Works in a manner which will minimise the number and duration of occupations and work permits required.
- 5.3 The network operator will not be liable for any financial or other loss suffered by the Contractor arising from his failure to complete any work scheduled during the period of an occupation or work permit.
- 5.4 The Contractor shall submit to the Contract Supervisor, in writing, requests for occupations or work permits together with details of the work to be undertaken, at least 21 days before they are required. The network operator does not undertake to grant an occupation or work permit for any particular date, time or duration.
- 5.5 The network operator reserves the right to cancel any occupation or work permit at any time before or during the period of occupation or work permit. If, due to cancellation or change in date or time, the Contractor is not permitted to start work under conditions of total occupation or work permit at the time arranged, all costs caused by the cancellation shall be born by the Contractor except as provided for in clauses 5.6 to 5.8.
- 5.6 When the Contractor is notified less than 2 hours before the scheduled starting time that the occupation or work permit is cancelled, he may claim reimbursement of his direct financial losses caused by the loss of working time up to the time his labour and plant are employed on other work, but not exceeding the period of the cancelled occupation or work permit.
- 5.7 When the Contractor is notified less than 2 hours before the scheduled starting time, or during an occupation or work permit, that the duration of the occupation or work permit is reduced, he may claim reimbursement of his direct financial losses caused by the loss of working time due to the reduced duration of the occupation or work permit.
- 5.8 Reimbursement of the Contractor for any loss of working time in terms of clause 5.6 and 5.7, shall be subject to his claims being submitted within 14 days of the event with full details of labour and plant involved, and provided that the Contract Supervisor certifies that no other work on which the labour and plant could be employed was immediately available.
- 5.9 Before starting any work for which an occupation has been arranged, the Contractor shall obtain from the Contract Supervisor written confirmation of the date, time and duration of the occupation.
- 5.10 Before starting any work for which a work permit has been arranged, the Responsible Representative shall read and sign portion C of the Work Permit, signifying that he is aware of the work boundaries within which work may be undertaken. After the work for which the permit was granted has been completed, or when the

work permit is due to be terminated, or if the permit is cancelled after the start, the same person who signed portion C shall sign portion D of the Work Permit, thereby acknowledging that he is aware that the electrical equipment is to be made "live". The Contractor shall advise all his workmen accordingly.

6.0 SPEED RESTRICTIONS AND PROTECTION

- 6.1 When speed restrictions are imposed by the network operator because of the Contractor's activities, the Contractor shall organise and carry out his work so as to permit the removal of the restrictions as soon as possible.
- 6.2 When the Contract Supervisor considers protection to be necessary the Contractor shall, unless otherwise agreed, provide all protection including flagmen, other personnel and all equipment for the protection of the network operator's and the Contractor's personnel and assets, the public and including trains.
- 6.2.1 The network operator will provide training free of charge of the Contractor's flagmen and other personnel performing protection duties. The Contractor shall consult with the Contract Supervisor, whenever he considers that protection will be necessary, taking into account the minimum permissible clearances set out in the Manual for Track Maintenance (Document no. BBB0481):
- Drawing no. BE-97 Sheet 1: Horizontal Clearances: 1065mm gauge (Annexure 1 sheet 1)
 - Drawing no. BE-97 Sheet 2: Vertical Clearances: 1065mm gauge (Annexure 1 sheet 2)
 - Drawing no. BE-97 Sheet 3: Clearances: Platform (Annexure 1 sheet 3)
 - Drawing no. BE-97 Sheet 5: Clearances: 610mm Gauge (Annexure 1 sheet 5)
- 6.3 The Contractor shall appoint a Responsible Representative to receive and transmit any instruction which may be given by the network operator personnel providing protection.

7.0 ROADS AND ROADS ON THE NETWORK OPERATOR'S PROPERTY

- 7.1 The Contractor shall take every reasonable precaution to prevent damage to any roads or bridges used to obtain access to the site, and shall select routes, use vehicles, and restrict loads so that any extraordinary traffic as may arise from the moving of plant or material to or from the site shall be limited as far as is reasonably possible.
- 7.2 The Contractor shall not occupy or interfere in any way with the free use of any public or private road, right-of-way, path or street unless the Contract Supervisor has obtained the approval of the road authority concerned.

8.0 CLEARANCES

- 8.1 No temporary works shall encroach on the appropriate minimum clearances set out in the Manual for Track Maintenance (Document no. BBB0481):
- Drawing no. BE-97 Sheet 1: Horizontal Clearances: 1065mm gauge (Annexure 1 sheet 1)
 - Drawing no. BE-97 Sheet 2: Vertical Clearances: 1065mm gauge (Annexure 1 sheet 2)
 - Drawing no. BE-97 Sheet 3: Clearances: Platform (Annexure 1 sheet 3)
 - Drawing no. BE-97 Sheet 5: Clearances: 610mm Gauge (Annexure 1 sheet 5)

9.0 STACKING OF MATERIAL

- 9.1 The Contractor shall not stack any material closer than 3m from the centre line of any railway line without prior approval of the Contract Supervisor.

10.0 EXCAVATION, SHORING, DEWATERING AND DRAINAGE

- 10.1 Unless otherwise approved by the Contract Supervisor any excavation adjacent to a railway line shall not encroach on the hatched area shown in Figure 1.

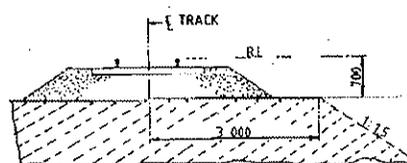

Fig. 1

- 10.2 The Contractor shall provide, at his own cost any shoring, dewatering or drainage of any excavation unless otherwise stipulated elsewhere in the Contract.
- 10.3 Where required by the Contract Supervisor, drawings of shoring for any excavation under or adjacent to a railway line shall be submitted and permission to proceed, obtained before the excavation is commenced.
- 10.4 The Contractor shall prevent ingress of water to the excavation but where water does enter, he shall dispose of it as directed by the Contract Supervisor.
- 10.5 The Contractor shall not block, obstruct or damage any existing drains either above or below ground level unless he has made adequate prior arrangements to deal with drainage.
- 11.0 FALSEWORK FOR STRUCTURES**
- 11.1 Drawings of falsework for the construction of any structure over, under or adjacent to any railway line shall be submitted to the Contract Supervisor and his permission to proceed obtained before the falsework is erected. Each drawing shall be given a title and a distinguishing number and shall be signed by a registered professional engineer certifying that he has checked the design of the falsework and that the drawings are correct and in accordance with the design.
- 11.2 After the falsework has been erected and before any load is applied, the Contractor shall submit to the Contract Supervisor a certificate signed by a registered professional engineer certifying that he has checked the falsework and that it has been erected in accordance with the drawings. Titles and numbers of the drawings shall be stated in the certificate. Notwithstanding permission given by the Contract Supervisor to proceed, the Contractor shall be entirely responsible for the safety and adequacy of the falsework.
- 12.0 PILING**
- 12.1 The Contract Supervisor will specify the conditions under which piles may be installed on the network operator's property.
- 13.0 UNDERGROUND SERVICES**
- 13.1 No pegs or stakes shall be driven or any excavation made before the Contractor has established that there are no underground services which may be damaged thereby.
- 13.2 Any damage shall be reported immediately to the Contract Supervisor, or to the official in charge at the nearest station, or to the traffic controller in the case of centralised traffic control.
- 14.0 BLASTING AND USE OF EXPLOSIVES**
- 14.1 When blasting within 500m of a railway line, the Contractor shall observe the requirements stipulated in this specification.
- 14.2 No blasting shall be carried out except with the prior written permission of the Contract Supervisor and under such conditions as he may impose.
- 14.3 On electrified lines the Contractor shall also obtain the permission of the Electrical Officer (Contracts) before blasting, and shall give at least 21 days notice of his intention to blast. No blasting shall be done in the vicinity of electrified lines unless a member of the network operator's electrical personnel is present.
- 14.4 The Contractor shall arrange for the supply, transport storage and use of explosives.
- 14.5 The Contractor shall have labour, tools and plant, to the satisfaction of the Contract Supervisor, available on the site to clear immediately any stones or debris deposited on the track or formation by blasting, and to repair any damage to the track or formation immediately after blasting. Repairs to the track shall be carried out only under the supervision of a duly authorised representative of the network operator.
- 14.6 The Contractor shall notify the Contract Supervisor of his intention to blast at least 21 days before the commencement of any blasting operations.
- 14.7 Before any blasting is undertaken, the Contractor and the Contract Supervisor shall jointly examine and measure up any buildings, houses or structures in the vicinity of the proposed blasting to establish the extent of any existing cracking or damage to such structures, etc. The Contractor, shall, subject to the provisions stipulated in the Contract Insurance Policy, make good any deterioration of such buildings, houses, or structures, which, in the opinion of the Contract Supervisor, was directly caused by the blasting.
- 14.8 After completion of the blasting the Contractor shall obtain a written clearance from each landowner in

the vicinity of the blasting operations to the effect that all claims for compensation in respect of damage caused by the blasting operations to their respective properties, have been settled.

- 14.9 The Contractor shall provide proof that he has complied with the provisions of clauses 10.17.1 to 10.17.4 of the Explosives Regulations (Act 26 of 1956 as amended).
- 14.10 Blasting within 500m of a railway line will only be permitted during intervals between trains. A person appointed by the Contract Supervisor, assisted by flagmen with the necessary protective equipment, will be in communication with the controlling railway station.
- Only this person will be authorised to give the Contractor permission to blast, and the Contractor shall obey his instructions implicitly regarding the time during which blasting may take place.
- 14.11 The flagmen described in clause 14.10, where provided by the network operator, are for the protection of trains and the network operator's property only, and their presence does not relieve the Contractor in any manner of his responsibilities in terms of Explosives Act or Regulations, or any obligation in terms of this Contract.
- 14.12 The person described in clause 14.10 will record in a book provided and retained by the network operator, the dates and times:-
- (i) when each request is made by him to the controlling station for permission to blast;
 - (ii) when blasting may take place;
 - (iii) when blasting actually takes place; and
 - (iv) when he advises the controlling station that the line is safe for the passage of trains.
- 14.13 Before each blast the Contractor shall record in the same book, the details of the blast to be carried out. The person appointed by the Contract Supervisor and the person who will do the blasting shall both sign the book whenever an entry described in clause 14.12 is made.

15.0 RAIL TROLLEYS

- 15.1 The use of rail trolleys or trestle trolleys on a railway line for working on high voltage equipment will be permitted only if approved by the Contract Supervisor and under the conditions stipulated by him.
- 15.2 All costs in connection with trolley working and any train protection services requested by the Contractor shall, be borne by the Contractor, unless otherwise agreed.

16.0 SIGNAL TRACK CIRCUITS

- 16.1 Where signal track circuits are installed, the Contractor shall ensure that no material capable of conducting an electrical current makes contact between rails of railway line/lines.
- 16.2 No signal connections on track-circuited tracks shall be severed without the Contract Supervisor's knowledge and consent.

17.0 PENALTY FOR DELAYS TO TRAINS

- 17.1 If any trains are delayed by the Contractor and the Contract Supervisor is satisfied that the delay was avoidable, a penalty will be imposed on the Contractor as stipulated in the contract, for the period and number of trains delayed.

18.0 SURVEY BEACONS AND PEGS

- 18.1 The Contractor shall not on any account move or damage any beacon, bench mark, reference mark, signal or trigonometrical station in the execution of the Works without the written approval of the Contract Supervisor.

Should the Contractor be responsible for any such occurrence, he shall report the circumstances to the Contract Supervisor who will arrange with the Director-General of Surveys for replacement of the beacon or mark at the cost of the Contractor.

- 18.2 The Contractor shall not move or damage any cadastral or mining beacon without the written approval of the Contract Supervisor and before it has been referenced by a registered land surveyor. Any old boundary beacon, which becomes an internal beacon on creation of new boundaries, shall not be moved without the written approval of the Contract Supervisor.

Should the Contractor move or damage any cadastral or mining beacon without authority, he shall be responsible for having it replaced, at his cost, by a land surveyor.

- 18.3 The Contractor shall preserve all pegs and bench marks. Such survey points shall not be removed without the written approval of the Contract Supervisor. Should any peg or benchmark be removed without authority, the Contract Supervisor will arrange for its replacement and the cost will be recovered from the Contractor. No claim will be considered for delay in replacing any such peg or bench mark. Each peg replaced shall be checked by the Contractor.
- 18.4 Where a new boundary has been established, beacons on the fence line shall not be disturbed, and fence posts or anchors may not be placed or excavations made within 0,6 m of any beacon without the prior written approval of the Contract Supervisor.

19.0 TEMPORARY LEVEL CROSSINGS

- 19.1 The Contract Supervisor may, on request of the Contractor, and if necessary for the purpose of execution of the Works, permit the construction of a temporary level crossing over a railway a line at a position approved by the Contract Supervisor and at the Contractor's cost. The period for which the temporary level crossing is permitted will be at the discretion of the Contract Supervisor.
- 19.2 The Contractor will provide protection and supervise the construction of the road over the track(s) and within the railway servitude at the level crossing, as well as the erection of all road signs and height gauges. All cost to be borne by the applicant.

The Contractor shall exercise extreme caution in carrying out this work, especially in respect of damage to tracks, services, overhead power and communications routes and prevent contact with "live" overhead electrical equipment.

Unless otherwise agreed, the Contractor will provide the service deviations or alterations to the network operator's track-, structure-, drainage-, electrical-, telecommunications- and train authorisation systems to accommodate the level crossing.

- 19.3 The Contractor shall take all necessary steps including the provision of gates, locks and, where necessary, watchmen to restrict the use of the temporary level crossing to himself and his employees, his subcontractors and their employees, the staff of the network operator and to such other persons as the Contract Supervisor may permit and of whose identity the Contractor will be advised. If so ordered by the Contract Supervisor, the Contractor shall provide persons to control road traffic using the temporary level crossing. Such persons shall stop all road traffic when any approaching train is within seven hundred and fifty (750) metres of the temporary level crossing, and shall not allow road traffic to proceed over it until the lines are clear.
- 19.4 The Contractor shall maintain the temporary level crossing within the railway servitude in good condition for the period it is in use. A temporary agreement with the road authority to be concluded for the maintenance of the level crossing outside the railway servitude.
- 19.5 When the temporary level crossing is no longer required by the Contractor, or permitted by the network operator, the Contractor shall at his own cost remove it and restore the site and the network operator's track-, structure-, drainage-, electrical-, telecommunications- and train authorisation systems to its original condition. Work over the tracks and within the railway servitude will be supervised by the network operator.

20.0 COMPLETION OF THE WORKS

- 20.1 On completion of the works, the Contractor shall remove all the remaining construction plant and material from the site, other than material which is the property of the network operator, and leave the site in a clean, neat and tidy condition. If material and plant is required for the liability and maintenance period the Contract supervisor must authorise it's retention on site.

21.0 PROTECTION OF PERSONS AND PROPERTY

- 21.1 The Contractor shall provide and maintain all lights, guards, barriers, fencing and watchmen when and where necessary or as required by the Contract Supervisor or by any statutory authority, for the protection of the Works and for the safety and convenience of the public.

Red, yellow, green or blue lights may not be used by the Contractor as they can be mistaken for signals. Red, yellow, green or white flags shall only be used for protection by the Contractor. Within the precincts of a port the Contractor shall obtain the permission of the Port Captain before installing any light.

- 21.2 The Contractor shall take all the requisite measures and precautions during the course of the Works to:
- (i) protect the public and property of the public,
 - (ii) protect the property and workmen of both the network operator and the Contractor,
 - (iii) avoid damage to and prevent trespass on adjoining properties, and
 - (iv) ensure compliance with any instruction issued by the Contract Supervisor or other authorised person, and with any stipulation embodied in the contract documents which affects the safety of any person or thing.
- 21.3 The network operator will provide, at its own cost, protection for the safe working of trains during such operations as the Contract Supervisor may consider necessary. Protection by the network operator for any purpose whatsoever, does not absolve the Contractor of his responsibilities in terms of the Contract.
- 21.4 The Contractor shall take all precautions and appoint guards, watchmen and compound managers for prevention of disorder among and misconduct by the persons employed on the Works and by any other persons, whether employees or not, on the work site and for the preservation of the peace and protection of persons and property in the direct neighbourhood. Any relocation of camps because of disorder shall be at the Contractor's expense.
- 21.5 All operations necessary for the execution of the Works, including the provision of any temporary work and camping sites, shall be carried out so as not to cause veldt fires, ground and environmental pollution, soil erosion or restriction of or interference with streams, furrows, drains and water supplies.
- If the original surface of the ground is disturbed in connection with the Works, it shall be made good by the Contractor to the satisfaction of the land owner, occupier or responsible authority.
- 21.6 The Contractor shall take all reasonable steps to minimise noise and disturbance when carrying out the Works, including work permitted outside normal working hours.
- 21.7 Dumping of waste or excess materials by the Contractor shall, in urban areas, be done under the direction and control of, and at sites made available by the local authority. Dumping outside local authority boundaries shall be done only with the express permission and under the direction and control of the Contract Supervisor.
- 21.8 The Contractor shall comply with environmental protection measures and specifications stipulated by the Contract Supervisor and/or local and environmental authorities.
- 22.0 INTERFERENCE WITH THE NETWORK OPERATOR'S ASSETS AND WORK ON OPEN LINES**
- 22.1 The Contractor shall not interfere in any manner whatsoever with an open line, nor shall he carry out any work or perform any act which affects the security, use or safety of an open line except with the authority of the Contract Supervisor and in the presence of a duly authorised representative of the network operator.
- 22.2 The Contractor shall not carry out any work or operate any plant, or place any material whatsoever nearer than three metres from the centre line of any open line except with the written permission of the Contract Supervisor and subject to such conditions as he may impose.
- 22.3 Care must be taken not to interfere with or damage any services such as overhead wire routes, cables or pipes and optical fibre cable, except as provided for the work specified. The Contractor will be held responsible for any damage to or interruption of such services arising from any act or omission on his part or of any of his employees, or persons engaged by him on the Works. The cost of repairing, replacing or restoring the services, as well as all other costs arising from any damage to services, shall be borne by, and will be recovered from the Contractor.
- 22.4 Authority granted by the Contract Supervisor and the presence of an authorised representative of the network operator in terms hereof, shall not relieve the Contractor of his duty to comply with this specification.
- 23.0 ACCESS, RIGHTS-OF-WAY AND CAMPSITES**
- 23.1 Where entry onto the network operator's property is restricted, permission to enter will be given only for the purpose of carrying out the Works and will be subject to the terms and conditions laid down by the network operator.
- 23.2 The Contractor shall arrange for campsites, workplaces and access thereto as well as for any right-of-

way over private property to the site of the Works, and for access within the boundaries of the network operator's property. The owners of private property to be traversed shall be approached and treated with tact and courtesy by the Contractor, who shall, if necessary, obtain a letter of introduction to such property owners from the Contract Supervisor.

The Contractor shall be responsible for the closing of all gates on roads and tracks used by him or his employees. Except with the prior approval of the Contract Supervisor and the owner or occupier of any private land to be traversed, the Contractor shall not cut, lower, damage, remove or otherwise interfere with any fence or gate which is either on the network operator's property or on private property and which restricts access to the Works. Where such approval has been given, the Contractor shall prevent entry of animals or unauthorised persons onto the network operator's or private property, and shall make the fences safe against trespass at the close of each day's work.

23.3 The Contractor shall take all reasonable steps to confine the movement of vehicles and plant to the approved right-of-way to minimise damage to property, crops and natural vegetation.

23.4 When access is no longer required, and before completion of the Works, the Contractor shall repair, restore or replace any fence or gate damaged during execution of the Works to the satisfaction of the Contract Supervisor and shall furnish the Contract Supervisor with a certificate signed by the owner and occupier of land over which he has gained access to a campsite, workplace and the Works, certifying that the owner and occupier have no claim against the Contractor or the network operator arising from the Contractor's use of the land. Should the Contractor be unable to obtain the required certificate, he shall report the circumstances to the Contract Supervisor.

24.0 SUPERVISION

24.1 The Contract Supervisor will provide overall technical superintendence of the Works, and may direct the Contractor in terms of the provisions of the Contract or in respect of any measures which the Contract Supervisor may require for the operations of the network operator, the safety of trains, property and workmen of the network operator, and for the safety of other property and persons. The Contractor shall carry out the directions of the Contract Supervisor. The superintendence exercised by the Contract Supervisor, including any agreement, approval, refusal or withdrawal of any approval given, shall not relieve the Contractor of any of his duties and liabilities under the Contract, and shall not imply any assumption by the network operator or by the Contract Supervisor of the legal and other responsibilities of the Contractor in carrying out the Works.

24.2 The Contract Supervisor may delegate to any deputy or other person, any of his duties or functions under the Contract. On receiving notice in writing of such delegation, the Contractor shall recognise and obey the deputy or person to whom any such duties or functions have been delegated as if he were the Contract Supervisor.

24.3 The Contractor shall exercise supervision over the Works at all times when work is performed or shall be represented by an agent having full power and authority to act on behalf of the Contractor. Such agent shall be competent and responsible, and have adequate experience in carrying out work of a similar nature to the Works, and shall exercise personal supervision on behalf of the Contractor. The Contract Supervisor shall be notified in writing of such appointment which will be subject to his approval.

24.4 The Contractor or his duly authorised agent shall be available on the site at all times while the Works are in progress to receive the orders and directions of the Contract Supervisor.

25.0 HOUSING OF EMPLOYEES

25.1 The Contractor shall, where necessary, make his own arrangements for suitable housing of his employees. Where temporary housing is permitted by the Contract Supervisor on any part of the site, the Contractor shall provide suitable sanitation, lighting and potable water supplies in terms of the requirements of the local authority or the current network operator's specification; Minimum Communal Health Requirements in Areas outside the Jurisdiction of a Local Authority - E.4B, as applicable.

25.2 Fouling the area inside or outside the network operator's boundaries shall be prevented. The Contractor will be called upon by the Contract Supervisor to dispose of any foul or waste matter generated by the Contractor.

26.0 OPTICAL FIBRE CABLE ROUTES

26.1 The Contractor shall not handle, impact, move or deviate any optical fibre cable without prior approval.

26.2 Works that in any way affect the optical fibre cable requires prior approval from the Contract Supervisor

who will determine the work method and procedures to be followed.

"PREVIEW COPY ONLY"

PART B - SPECIFICATION FOR WORK NEAR HIGH-VOLTAGE ELECTRICAL EQUIPMENT**27.0 GENERAL**

27.1 This specification is based on the contents of Transnet's publication ELECTRICAL SAFETY INSTRUCTIONS, as amended, a copy of which will be made available on loan to the Contractor for the duration of the contract.

These instructions apply to all work near "live" high-voltage equipment maintained and/or operated by the network operator, and the onus rests on the Contractor to ensure that he obtains a copy.

27.2 This specification must be read in conjunction with and not in lieu of the Electrical Safety Instructions.

27.3 The Contractor's attention is drawn in particular to the contents of Part I, Sections 1 and 2 of the Electrical Safety Instructions.

27.4 The Electrical Safety Instructions cover the minimum safety precautions which must be taken to ensure safe working on or near high-voltage electrical equipment, and must be observed at all times. Should additional safety measures be considered necessary because of peculiar local conditions, these may be ordered by and at the discretion of the Electrical Officer (Contracts).

27.5 The Contractor shall obtain the approval of the Electrical Officer (Contracts) before any work is done which causes or could cause any portion of a person's body or the tools he is using or any equipment he is handling, to come within 3 metres of any "live" high-voltage equipment.

27.6 The Contractor shall regard all high-voltage equipment as "live" unless a work permit is in force.

27.7 Safety precautions taken or barriers erected shall comply with the requirements of the Electrical Officer (Contracts), and shall be approved by him before the work to be protected is undertaken by the Contractor. The Contractor shall unless otherwise agreed, bear the cost of the provision of the barriers and other safety precautions required, including the attendance of the network operator's staff where this is necessary.

27.8 No barrier shall be removed unless authorised by the Electrical Officer (Contracts).

28.0 WORK ON BUILDINGS OR FIXED STRUCTURES

28.1 Before any work is carried out or measurements are taken on any part of a building, fixed structure or earthworks of any kind above ground level situated within 3 metres of "live" high-voltage equipment, the Electrical Officer (Contracts) shall be consulted to ascertain the conditions under which the work may be carried out.

28.2 No barrier erected to comply with the requirements of the Electrical Officer (Contracts) shall be used as temporary staging or shuttering for any part of the Works.

28.3 The shuttering for bridge piers, abutments, retaining walls or parapets adjacent to or over any track may be permitted to serve as a barrier, provided that it extends at least 2,5 metres above any working level in the case of piers, abutments and retaining walls and 1,5 metres above any working level in the case of parapets.

29.0 WORK DONE ON OR OUTSIDE OF ROLLING STOCK, INCLUDING LOADING OR UNLOADING

29.1 No person may stand, climb or work, whilst on any platform, surface or foothold:

29.1.1 higher than the normal unrestricted access way, namely -

29.1.1.1 external walkways on diesel, steam and electric locomotives, steam heat vans, etc. and

29.1.1.2 walkways between coaches and locomotives.

29.1.2 of restricted access ways in terms of the Electrical Safety Instructions namely -

29.1.2.1 the floor level of open wagons

29.1.2.2 external walkways or decks of road-rail vehicles, on-track maintenance machines and material trains.

29.1.3 Unauthorised staff working on these platforms must be directly supervised by duly authorised persons in terms of clause 607.1.3 of the Electrical Safety Instructions. These persons must attend the relevant electrical safety module training. A letter of training must then be issued by an accredited training authority. A Category C Certificate of Authority must be obtained from the

local depot examining officer.

- 29.2 When in the above positions no person may raise his hands or any equipment he is handling above his head.
- 29.3 In cases where the Contractor operates his own rail mounted equipment, he shall arrange for the walkways on this plant to be inspected by the Electrical Officer (Contracts) and approved, before commencement of work.
- 29.4 The handling of long lengths of material such as metal pipes, reinforcing bars, etc should be avoided, but if essential they shall be handled as nearly as possible in a horizontal position below head height.
- 29.5 The Responsible Representative shall warn all persons under his control of the danger of being near "live" high-voltage equipment, and shall ensure that the warning is fully understood.
- 29.6 Where the conditions in clauses 30.1 to 30.4 cannot be observed the Electrical Officer (Contracts), shall be notified. He will arrange for suitable Safety measures to be taken. The Electrical Officer (Contracts), may in his discretion and in appropriate circumstances, arrange for a suitable employee of the Contractor to be specially trained by the network operator and at the Contractor's cost, as an Authorised Person to work closer than 3 metres from "live" overhead conductors and under such conditions as may be imposed by the senior responsible electrical engineer of the network operator.

30.0 USE OF EQUIPMENT

30.1 Measuring Tapes and Devices

- 30.1.1 Measuring tapes may be used near "live" high-voltage equipment provided that no part of any tape or a person's body comes within 3 metres of the "live" equipment.
- 30.1.2 In windy conditions the distance shall be increased to ensure that if the tape should fall it will not be blown nearer than 3 metres from the "live" high-voltage equipment.
- 30.1.3 Special measuring devices longer than 2 metres such as survey sticks and rods may be used if these are of non-conducting material and approved by the responsible Electrical Engineer of the network operator, but these devices must not be used within 3 metres of "live" high-voltage equipment in rainy or wet conditions.
- 30.1.4 The assistance of the Electrical Officer (Contracts) shall be requested when measurements within the limits defined in clauses 31.1.1 to 31.1.3 are required.
- 30.1.5 The restrictions described in 31.1.1 to 31.1.3 do not apply on a bridge deck between permanent parapets nor in other situations where a barrier effectively prevents contact with the "live" high-voltage equipment.

30.2 Portable Ladders

- 30.2.1 Any type of portable ladder longer than 2 metres may only be used near "live" high-voltage equipment under the direct supervision of the Responsible Representative. He shall ensure that the ladder is always used in such a manner that the distance from the base of the ladder to any "live" high-voltage equipment is greater than the fully extended length of the ladder plus 3 metres. Where these conditions cannot be observed, the Electrical Officer (Contracts) shall be advised, and he will arrange for suitable safety measures to be taken.

31.0 CARRYING AND HANDLING MATERIAL AND EQUIPMENT

- 31.1 Pipes, scaffolding, iron sheets, reinforcing bars and other material which exceeds 2 metres in length shall be carried completely below head height near "live" high-voltage equipment. For maximum safety such material should be carried by two or more persons so as to maintain it as nearly as possible in a horizontal position. The utmost care must be taken to ensure that no part of the material comes within 3 metres of any "live" high-voltage equipment.
- 31.2 Long lengths of wire or cable shall never be run out in conditions where a part of a wire or cable can come within 3 metres of any "live" high-voltage equipment unless the Electrical Officer (Contracts) has been advised and has approved appropriate safety precautions.
- 31.3 The presence of overhead power lines shall always be taken account of especially when communications lines or cables or aerial cables, stay wires, etc. are being erected above ground level.

32.0 PRECAUTIONS TO BE TAKEN WHEN ERECTING OR REMOVING POLES, ANTENNAE, TREES ETC.

- 32.1 A pole may be handled for the purpose of erection or removal near high-voltage equipment under the following conditions:

(i) If the distance between the point at which the pole is to be erected or removed and the nearest "live" high-voltage equipment is more than the length of the pole plus 3 metres, the work shall be supervised by the Responsible Representative.

(ii) If the distance described in (i) is less than the length of the pole plus 3 metres, the Electrical Officer (Contracts) shall be consulted to arrange for an Authorised Person to supervise the work and to ensure that the pole is earthed where possible. The pole shall be kept in contact with the point of erection, and adequate precautions shall be taken to prevent contact with "live" high-voltage equipment.

32.2 The cost of supervision by an Authorised Person and the provision of earthing shall, unless otherwise agreed, be borne by the Contractor.

32.3 The provisions of clauses 33.1 and 33.2 shall also apply to the erection or removal of columns, antennae, trees, posts, etc.

33.0 USE OF WATER

33.1 No water shall be used in the form of a jet if it can make contact with any "live" high-voltage equipment or with any person working on such equipment.

34.0 USE OF CONSTRUCTION PLANT

34.1 "Construction plant" entails all types of plant including cranes, piling frames, boring machines, excavators, draglines, dewatering equipment and road vehicles with or without lifting equipment.

34.2 When work is being undertaken in such a position that it is possible for construction plant or its load to come within 3 metres of "live" high-voltage equipment, the Electrical Officer (Contracts) shall be consulted. He will arrange for an Authorised Person to supervise the work and to ensure that the plant is adequately earthed. The Electrical Officer (Contracts) will decide whether further safety measures are necessary.

34.3 The cost of any supervision by an Authorised Person and the provision of earthing shall, unless otherwise agreed, be borne by the Contractor.

34.4 When loads are handled by cranes, non-metallic rope hand lines shall be used, affixed to such loads so as to prevent their swinging and coming within 3 metres of "live" high-voltage equipment.

34.5 Clauses 35.1 to 35.4 shall apply *mutatis mutandis* to the use of maintenance machines of any nature.

35.0 WORK PERFORMED UNDER DEAD CONDITIONS UNDER COVER OF A WORK PERMIT

35.1 If the Responsible Representative finds that the work cannot be done in safety with the high-voltage electrical equipment "live", he shall consult the Electrical Officer (Contracts) who will decide on the action to be taken.

35.2 If a work permit is issued the Responsible Representative shall-

(i) before commencement of work ensure that the limits within which work may be carried out have been explained to him by the Authorised Person who issued the permit to him, and that he fully understands these limits.

(ii) sign portion C of the permit before commencement of work;

(iii) explain to all persons under his control the limits within which work may be carried out, and ensure that they fully understand these limits;

(iv) care for the safety of all persons under his control whilst work is in progress; and

(v) withdraw all personnel under his control from the equipment on completion of the work before he signs portion D of the work permit.

36.0 TRACTION RETURN CIRCUITS IN RAILS

36.1 DANGEROUS CONDITIONS CAN BE CREATED BY REMOVING OR SEVERING ANY BOND.

36.2 Broken rails with an air gap between the ends, and joints at which fishplates are removed under "broken bond" conditions, are potentially lethal. The rails on either side of an air gap between rail ends on electrified lines shall not be touched simultaneously until rendered safe by the network operator personnel.

36.3 The Contractor shall not break any permanent bonds between rails or between rails and any structure. He shall give the Contract Supervisor at least 7 days written notice when removal of such bonds is necessary.

36.4 No work on the track which involves interference with the traction return rail circuit either by cutting or removing the rails, or by removal of bonds shall be done unless the Electrical Officer (Contracts) is consulted. He will take such precautions as may be necessary to ensure continuity of the return circuit before permitting the work to be commenced.

37.0 HIGH-VOLTAGE ELECTRICAL EQUIPMENT NOT MAINTAINED AND/OR OPERATED BY THE NETWORK OPERATOR

Where the work is undertaken on or near high-voltage electrical equipment which is not maintained and/or operated by the network operator, the Occupational Health and Safety Act No. 85 of 1993, and Regulations and Instructions, or the Mines Health and Safety Act (Act 29 of 1996), shall apply.

Such equipment includes:-

- (i) Eskom and municipal equipment;
- (ii) The Contractor's own power supplies; and
- (iii) Electrical equipment being installed but not yet taken over from the Contractor.

END

"PREVIEW COPY ONLY"

VERTICAL CLEARANCES :
1 065mm TRACK GAUGE

ANNEXURE 1
SHEET 2 of 5

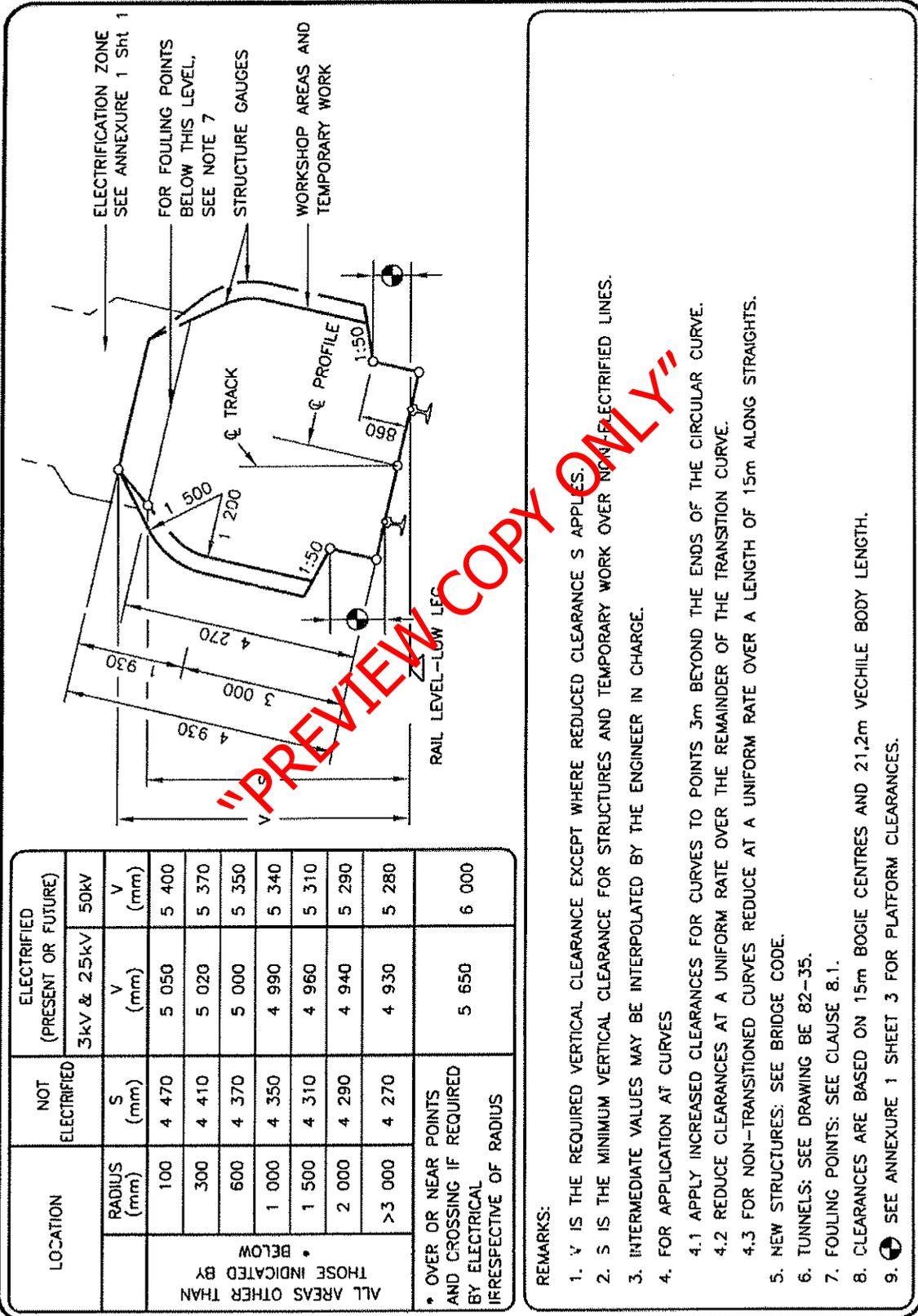

LOCATION	NOT ELECTRIFIED	ELECTRIFIED (PRESENT OR FUTURE)	
		3kV & 2.5kV	50kV
	S (mm)	V (mm)	V (mm)
	100	5 050	5 400
	300	5 020	5 370
	600	5 000	5 350
	1 000	4 990	5 340
	1 500	4 960	5 310
	2 000	4 940	5 290
	>3 000	4 930	5 280
		5 650	6 000

• BELOW
* OVER OR NEAR POINTS AND CROSSING IF REQUIRED BY ELECTRICAL IRRESPECTIVE OF RADIUS
ALL AREAS OTHER THAN THOSE INDICATED BY

REMARKS:

1. V IS THE REQUIRED VERTICAL CLEARANCE EXCEPT WHERE REDUCED CLEARANCE S APPLIES.
2. S IS THE MINIMUM VERTICAL CLEARANCE FOR STRUCTURES AND TEMPORARY WORK OVER NON-ELECTRIFIED LINES.
3. INTERMEDIATE VALUES MAY BE INTERPOLATED BY THE ENGINEER IN CHARGE.
4. FOR APPLICATION AT CURVES
 - 4.1 APPLY INCREASED CLEARANCES FOR CURVES TO POINTS 3m BEYOND THE ENDS OF THE CIRCULAR CURVE.
 - 4.2 REDUCE CLEARANCES AT A UNIFORM RATE OVER THE REMAINDER OF THE TRANSITION CURVE.
 - 4.3 FOR NON-TRANSITIONED CURVES REDUCE AT A UNIFORM RATE OVER A LENGTH OF 15m ALONG STRAIGHTS.
5. NEW STRUCTURES: SEE BRIDGE CODE.
6. TUNNELS: SEE DRAWING BE 82-35.
7. FOULING POINTS: SEE CLAUSE 8.1.
8. CLEARANCES ARE BASED ON 15m BOGIE CENTRES AND 21.2m VEHICLE BODY LENGTH.
9. ● SEE ANNEXURE 1 SHEET 3 FOR PLATFORM CLEARANCES.

CLEARANCES : PLATFORMS

ANNEXURE 1
SHEET 3 of 5

PLATFORMS : TRACK GAUGE 1 065mm

PASSENGERS

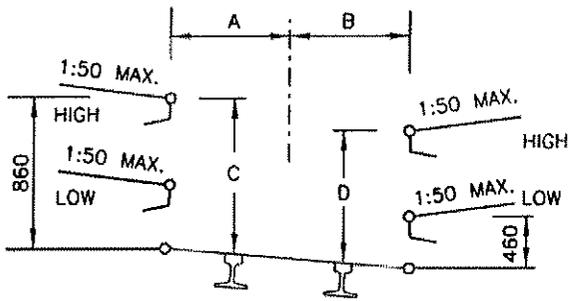

GOODS

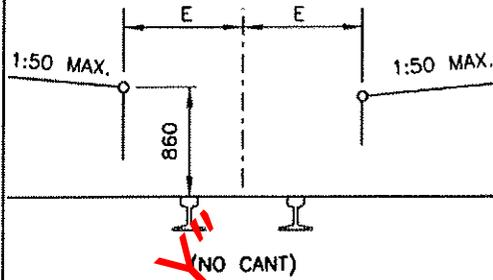

RADIUS (m)	A (mm)	B (mm)	C (mm)	D (mm)	E (mm)
90	1 690	1 820	890	810	1 840
100	1 650	1 790	890	810	1 810
120	1 610	1 740	890	810	1 760
140	1 580	1 700	890	810	1 720
170	1 550	1 660	890	810	1 690
200	1 530	1 630	890	820	1 670
250	1 520	1 600	890	820	1 640
300	1 520	1 580	890	830	1 620
350	1 520	1 560	880	830	1 600
400	1 520	1 550	880	840	1 590
500	1 520	1 540	880	850	1 580
600	1 520	1 530	870	850	1 570
800	1 520	1 520	860	860	1 560
1 200	1 520	1 520	860	860	1 550
2 000	1 520	1 520	860	860	1 540
3 000	1 520	1 520	860	880	1 530
STRAIGHT	1 520	1 520	860	860	1 520

REMARKS:

1. NO CANT TO BE APPLIED EXCEPT WHEN THE GOODS PLATFORM IS ON A RUNNING LINE.
2. INTERMEDIATE VALUES MAY BE INTERPOLATED BY THE ENGINEER IN CHARGE.
3. 8m TO MAIN STATION-BUILDINGS AND 3m TO ALL OTHER STRUCTURES.
4. TOLERANCES : SEE CLAUSE 8.0.10.
5. ALWAYS USE THE SMALLEST RADIUS

STRUCTURES ON PLATFORMS : 1 065mm AND 610mm TRACK GAUGE

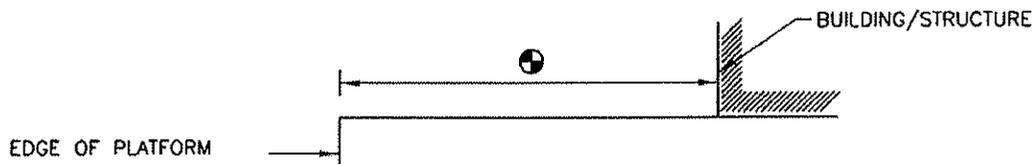

CLEARANCES : 610mm TRACK GAUGE

ANNEXURE 1
SHEET 5 of 5

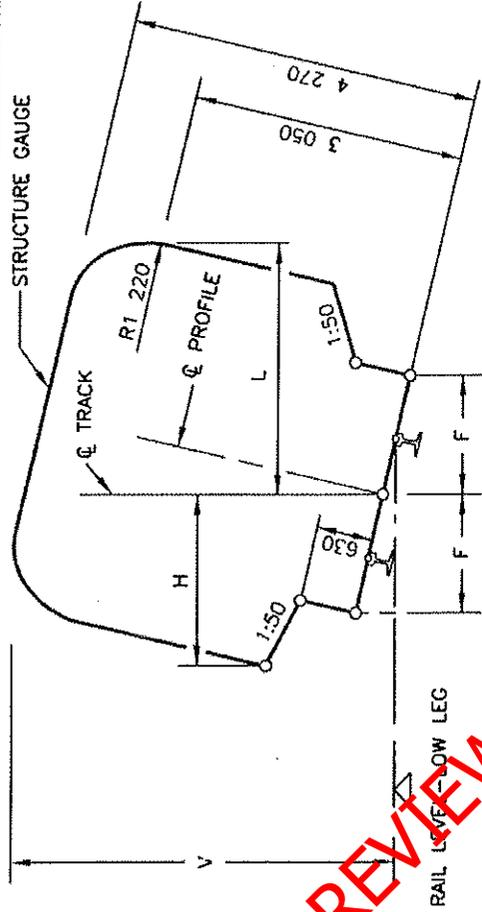

RADIUS (m)	F (mm)
50	1 550
60	1 510
80	1 460
100	1 430
120	1 410
140	1 390
170	1 380
200	1 370
250	1 360
300	1 350
600	1 330
1 000	1 320
>2 000	1 320
STRAIGHT	1 310

RADIUS (m)	WITH CANT		NO CANT		V (mm)
	H (mm)	L (mm)	H & L (mm)		
50	2 370	2 490	2 400	4 320	4 320
70	2 310	2 420	2 330	4 310	4 310
100	2 260	2 370	2 280	4 310	4 310
140	2 220	2 340	2 250	4 310	4 310
200	2 200	2 300	2 220	4 300	4 300
300	2 190	2 270	2 200	4 300	4 300
500	2 180	2 230	2 190	4 290	4 290
700	2 170	2 200	2 180	4 270	4 270
1 000	2 170	2 170	2 170	4 270	4 270
>2 000	2 160	2 160	2 160	4 270	4 270

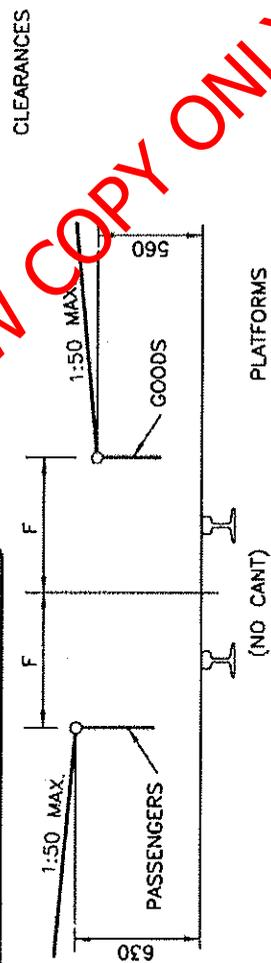

"PREVIEW COPY ONLY"

REMARKS:

- H IS THE MINIMUM HORIZONTAL CLEARANCE ON THE OUTSIDE OF THE CURVE BASED ON MINIMUM CANT.
- L IS THE MINIMUM HORIZONTAL CLEARANCE ON THE INSIDE OF THE CURVE BASED ON MAXIMUM CANT.
- V IS THE MINIMUM VERTICAL CLEARANCE.
- FOR APPLICATION AT CURVES:
 - APPLY INCREASED CLEARANCES FOR CURVES TO POINTS 2m BEYOND THE ENDS OF THE CIRCULAR CURVE.
 - REDUCE CLEARANCES AT A UNIFORM RATE OVER THE REMAINDER OF THE TRANSITION CURVE.
 - FOR NON-TRANSITIONED CURVES REDUCE AT A UNIFORM RATE OVER A LENGTH OF 18m ALONG STRAIGHTS.
- INTERMEDIATE VALUES MAY BE INTERPOLATED BY THE ENGINEER IN CHARGE.
- ALSO REFER TO REMARKS 5, 6 AND 7 OF ANNEXURE 1 SHEET 2.
- CLEARANCES ARE BASED ON 9 700mm BOGIE CENTRES AND 13 700mm VEHICLE BODY LENGTH.
- SEE ANNEXURE 1 SHEET 3 FOR STRUCTURES ON PLATFORMS.