



Transnet Freight Rail, a division of

TRANSNET SOC LTD

Registration Number 1990/000900/30

[hereinafter referred to as **Transnet**]

REQUEST FOR QUOTATION [RFQ] No RME CPT 159/2014

**FOR THE FABRICATE, SUPPLY AND DELIVERY OF: GALVANISED STEEL COLUMNS
AND BEAMS**

**FOR DELIVERY TO: 19 VOORTREKKER ROAD, TRE DEPOT, SALTRIVER
WESTERN CAPE**

ISSUE DATE:	05 AUGUST 2014
COMPULSORY SITE BRIEFING:	12 AUGUST 2014
CLOSING DATE:	19 AUGUST 2014
CLOSING TIME:	10:00

Section 1
NOTICE TO BIDDERS

Quotations which must be completed as indicated in Section 2 of this RFQ are to be submitted as follows:

METHOD: Post; Courier and Hand delivery
CLOSING VENUE: SEE BELOW FOR CLOSING VENUE

1 FORMAL BRIEFING

A compulsory pre-proposal site inspection will be conducted at **Opposite Bay 6, 19 Voortrekker Road, TRE Depot, Salt River, Western Cape, on the 12th of August 2014, at 11:00 am.** [Respondents to provide own transportation and accommodation]. The briefing session will start punctually and information will not be repeated for the benefit of Respondents arriving late. **Contact Bert Laubscher for site meeting and other logistics, cell phone number: 083 8520 711**

1.1 Respondents failing to attend the compulsory site meeting and/or RFP briefing will be disqualified.

2 Responses to RFQ

Responses to this RFQ [**Quotations**] must not include documents or reference relating to any other quotation or proposal. Any additional conditions must be embodied in an accompanying letter. Proposals must reach the Secretariat, Acquisition Council before the closing hour on the date shown below, and must be enclosed in a sealed envelope which must have inscribed on the outside:

RFQ No: RME CPT 159/2014
Description: **FABRICATE, SUPPLY & DELIVERY OF GALVANISED STEEL COLUMNS AND BEAMS**

Closing date and time: 19 AUGUST 2014 AT 10H00 Sharp

Closing address [Refer to options in Delivery Instructions for RFQ below]

All envelopes must reflect the return address of the Respondent on the reverse side.

1 DELIVERY INSTRUCTIONS FOR RFQ

1.1 Delivery by hand

If delivered by hand, the envelope is to be deposited in the Transnet Freight Rail (RME) Tender box which is located at the main entrance of Transnet Park, Robert Sobukwe Road, Bellville, and should be addressed as follows:

THE SECRETARIAT
ACQUISITION COUNCIL
TRANSNET PARK
TENDER BOX
ROBERT SOBUKWE ROAD
BELLVILLE 7535

The measurements of the "tender slot" are 400mm wide x 100mm high, and Respondents must please ensure that response documents or files are no larger than the above dimensions. Responses which are too bulky [i.e. more than 100mm thick] must be split into two or more files, and placed in separate envelopes, each such envelope to be addressed as above.

1.2 Dispatch by courier

If dispatched by courier, the envelope must be addressed as follows and delivered to the Office of The Secretariat, Acquisition Council and a signature obtained from that Office:

THE SECRETARIAT
TRANSNET ACQUISITION COUNCIL
6TH FLOOR
TRANSNET PARK
ROBERT SOBUKWE ROAD
BELLVILLE 7535

Please note that this RFQ closes punctually at **10:00 on Tuesday, 19 August 2014.**

1. If responses are not delivered as stipulated herein, such responses will not be considered and will be treated as "NON-RESPONSIVE" and will be disqualified.
2. No email or facsimile responses will be considered, unless otherwise stated herein.
3. The responses to this RFQ will be opened as soon as practicable after the expiry of the time advertised for receiving them.
4. Transnet shall not, at the opening of responses, disclose to any other company any confidential details pertaining to the Proposals / information received, i.e. pricing, delivery, etc. The names and locations of the Respondents will be divulged to other Respondents upon request.
5. Envelopes must not contain documents relating to any RFQ other than that shown on the envelope.

3 Broad-Based Black Economic Empowerment [B-BBEE]

Transnet fully endorses and supports the Government's Broad-Based Black Economic Empowerment Programme and it would therefore prefer to do business with local business enterprises who share these same values. Transnet will accordingly allow a "preference" to companies who provide a valid B-BBEE Verification Certificate. All procurement transactions will be evaluated accordingly.

3.1 B-BBEE Scorecard and Rating

As prescribed in terms of the Preferential Procurement Policy Framework Act (PPPFA), Act 5 of 2000 and its Regulations, Respondents are to note that the following preference point systems are applicable to all bids:

- the 80/20 system for requirements with a Rand value of up to R1 000 000 (all applicable taxes included); and
- the 90/10 system for requirements with a Rand value above R1 000 000 (all applicable taxes included).

- Bidders are to note that if the 80/20 preference point system is stipulated in this RFQ and all Bids received exceed R1 000 000.00, the RFQ must be cancelled. Similarly, if the 90/10 preference point system is stipulated in this RFQ and all Bids received are equal to or below R1 000 000.00, the RFQ must be cancelled.

The value of this bid is estimated to be below R1 000 000.00 and therefore R1 000 000.00 (all applicable taxes included) and therefore the **80/20** system shall be applicable. When Transnet invites prospective suppliers to submit Proposals for its various expenditure programmes, it requires Respondents to have their B-BBEE status verified in compliance with the Codes of Good Practice issued in terms of the Broad Based Black Economic Empowerment Act No. 53 of 2003.

The Department of Trade and Industry recently revised the Codes of Good Practice on 11 October 2013 [Government Gazette No. 36928]. The Revised Codes will replace the Black Economic Empowerment Codes of Good Practice issued on 9 February 2007. The Revised Codes provide for a one year transitional period starting 11 October 2013. During the transitional period, companies may elect to be measured in terms of the Revised Codes or the 2007 version of the Codes. After the first year of the implementation of the Revised Codes, B-BBEE compliance will be measured in terms of the Revised Codes without any discretion. Companies which are governed by Sector-specific Codes will be measured in terms of those Sector Codes.

As such, Transnet will accept B-BBEE certificates issued based on the Revised Codes. Transnet will also continue to accept B-BBEE certificates issued in terms of the 2007 version of the Codes provided it was issued before 10 October 2014. Thereafter, Transnet will only accept B-BBEE certificates issued based on the Revised Codes.

Note: Failure to submit a valid and original B-BBEE certificate or a certified copy thereof at the Closing Date of this RFQ will result in a score of zero being allocated for B-BBEE.

[Refer clause 20 below for Returnable Documents required]

4 Communication

Respondents are warned that a response will be liable for disqualification should any attempt be made by a Respondent either directly or indirectly to canvass any officer(s) or employee of Transnet in respect of this RFQ between the closing date and the date of the award of the business.

A Respondent may, however, before the closing date and time, direct any written enquiries relating to the RFQ to the following Transnet employees:

Name: Bert Laubscher Email: Bert.Laubscher@transnet.net
Telephone: 083 852 0711

Respondents may also, at any time before or after the closing date of the RFQ, communicate with the following Transnet Employee on any administrative matters relating to its RFQ response:

Name: Thabisile Ndlovu
Telephone: 021 940 1840 Email: Thabisile.Ndlovu@transnet.net

5 Tax Clearance

The Respondent's original and valid Tax Clearance Certificate must accompany the Quotation. Note that no business shall be awarded to any Respondent whose tax matters have not been declared by SARS to be in order.

6 VAT Registration

The valid VAT registration number must be stated here: _____ [if applicable].

7 Legal Compliance

The successful Respondent shall be in full and complete compliance with any and all applicable national and local laws and regulations.

8 Changes to Quotations

Changes by the Respondent to its submission will not be considered after the closing date and time.

9 Pricing

All prices must be quoted in South African Rand on a fixed price basis, excluding VAT.

10 Prices Subject to Confirmation

Prices quoted which are subject to confirmation will not be considered.

11 Negotiations

Transnet reserves the right to undertake post-tender negotiations with selected Respondents or any number of shortlisted Respondents.

12 Binding Offer

Any Quotation furnished pursuant to this Request shall be deemed to be an offer. Any exceptions to this statement must be clearly and specifically indicated.

13 Disclaimers

Transnet is not committed to any course of action as a result of its issuance of this RFQ and/or its receipt of a Quotation in response to it. Please note that Transnet reserves the right to:

- modify the RFQ's goods / service(s) and request Respondents to re-bid on any changes;
- reject any Quotation which does not conform to instructions and specifications which are detailed herein;
- disqualify Quotations submitted after the stated submission deadline;
- not necessarily accept the lowest priced Quotation;
- reject all Quotations, if it so decides;
- place an order in connection with this Quotation at any time after the RFQ's closing date;
- award only a portion of the proposed goods / service/s which are reflected in the scope of this RFQ;
- split the award of the order/s between more than one Supplier/Service Provider; or
- make no award at all.

Respondent's Signature

Date & Company Stamp

Transnet reserves the right to award business to the highest scoring bidder/s unless objective criteria justify the award to another bidder.

14 Transnet's supplier integrity pact

Transnet's Integrity Pact requires a commitment from suppliers and Transnet that they will not engage in any corrupt and fraudulent practices, anti-competitive practices; and act in bad faith towards each other. The Integrity Pact also serves to communicate Transnet's Gift Policy as well as the remedies available to Transnet where a Respondent contravenes any provision of the Integrity Pact.

Respondents are required to familiarise themselves with the contents of the Integrity Pact which is available on the Transnet Internet site [www.transnet.net/Tenders/Pages/default.aspx] or on request. Furthermore, Respondents are required to certify that they have acquainted themselves with all the documentation comprising the Transnet Integrity Pact and that they fully comply with all the terms and conditions stipulated in the Transnet Supplier Integrity Pact as follows:

YES		NO	
------------	--	-----------	--

Should a Respondent need to declare previous transgressions or a serious breach of law in the preceding 5 years as required by Annexure A to the Integrity Pact, such declaration must accompany the Respondent's bid submission.

15 Evaluation Criteria

Transnet will utilise the following criteria [not necessarily in this order] in choosing a Supplier/Service Provider, if so required:

Criterion/Criteria	Explanation
Administrative responsiveness	Completeness of response and returnable documents
Substantive responsiveness	Prequalification criteria, if any, must be met and whether the Bid materially complies with the scope and/or specification given.
Final weighted evaluation based on 80/20 preference point system as indicated in paragraph 3	<ul style="list-style-type: none"> Pricing and price basis [firm] - whilst not the sole factor for consideration, competitive pricing and overall level of unconditional discounts¹ will be critical B-BBEE status of company - Preference points will be awarded to a bidder for attaining the B-BBEE status level of contribution in accordance with the table indicated below.

¹ Only unconditional discounts will be taken into account during evaluation. A discount which has been offered conditionally will, despite not being taken into account for evaluation purposes, be implemented when payment is effected.

Preference points will be awarded to a bidder for attaining the B-BBEE status level of contribution in accordance with the table below:

B-BBEE Status Level of Contributor	Number of points (80/20 system)
1	20
2	18
3	16
4	12
5	8
6	6
7	4
8	2
Non-compliant contributor	0

16 Validity Period

Transnet desires a validity period of 30 [thirty] days from the closing date of this RFQ.
This RFQ is valid until _____.

17 Banking Details

BANK: _____
BRANCH NAME / CODE: _____
ACCOUNT HOLDER: _____
ACCOUNT NUMBER: _____

18 Company Registration

Registration number of company / C.C. _____
Registered name of company / C.C. _____

19 Disclosure of Prices Quoted

Respondents must indicate here whether Transnet may disclose their quoted prices and conditions to other Respondents:

YES NO

20 Returnable Documents

Returnable Documents means all the documents, Sections and Annexures, as listed in the tables below.

- a) Respondents are required to submit with their Quotations the **mandatory Returnable Documents**, as detailed below.

Respondent's Signature

Date & Company Stamp

Failure to provide all these Returnable Documents at the Closing Date and time of this RFQ will result in a Respondent's disqualification. Respondents are therefore urged to ensure that all these Documents are returned with their Quotations.

All Sections, as indicated in the footer of each page, must be signed, stamped and dated by the Respondent. Please confirm submission of these mandatory Returnable Documents by so indicating [Yes or No] in the table below:

Mandatory Returnable Documents	Submitted [Yes or No]
SECTION 2 : Quotation Form	
ANNEXURE B: Bill of Quantities & Technical Specification	

- b) In addition to the requirements of section (a) above, Respondents are further required to submit with their Quotations the following **essential Returnable Documents** as detailed below.

Failure to provide all these Returnable Documents may result in a Respondent's disqualification. Respondents are therefore urged to ensure that all these documents are returned with their Quotations.

All Sections, as indicated in the footer of each page, must be signed, stamped and dated by the Respondent. Please confirm submission of these essential Returnable Documents by so indicating [Yes or No] in the table below:

Essential Returnable Documents	Submitted [Yes or No]
SECTION 1 : Notice to Bidders	
- Valid and original B-BBEE Verification Certificate or certified copy thereof [Large Enterprises and QSEs] Note: failure to provide a valid B-BBEE Verification Certificate at the closing date and time of the RFQ will result in an automatic score of zero for preference	
- Valid and original B-BBEE certificate/sworn affidavit or certified copy thereof from auditor, accounting officer or SANAS accredited Verification Agency [EMEs] Note: failure to provide a valid B-BBEE Verification Certificate at the closing date and time of the RFQ will result in an automatic score of zero being allocated for preference	
- In the case of Joint Ventures, a copy of the Joint Venture Agreement or written confirmation of the intention to enter into a Joint Venture Agreement	
- Original valid Tax Clearance Certificate [Consortia / Joint Ventures must submit a separate Tax Clearance Certificate for each party]	
- SECTION 3 : Standard Terms and Conditions of Contract for the Supply of Goods or Services to Transnet	
SECTION 4 : Vendor Application Form	
- Original cancelled cheque or bank verification of banking details	
- Certified copies of IDs of shareholder/directors/members [as applicable]	
- Certified copies of the relevant company registration documents from	

Respondent's Signature

Date & Company Stamp

Essential Returnable Documents	Submitted [Yes or No]
Companies and Intellectual Property Commission (CIPC)	
- Certified copies of the company's shareholding/director's portfolio	
- Entity's letterhead	
- Certified copy of VAT Registration Certificate [RSA entities only]	
- Certified copy of valid Company Registration Certificate [if applicable]	
- A signed letter from Respondent's auditor or accountant confirming most recent annual turnover figures	
- Financial Statements signed by your Accounting Officer or Audited Financial Statements for previous 3 years	

- c) In addition to the requirements of paragraph a) and b) above, Respondents are further requested to submit with their Proposals the following **additional documents** as detailed below.

Please confirm submission of these additional documents by so indicating [Yes or No] in the table below:

Additional Documents	SUBMITTED [Yes or No]
ANNEXURE A : B-BBEE Improvement Plan	

Respondent's Signature

Date & Company Stamp

Section 2 QUOTATION FORM

I/We _____
hereby offer to supply the goods/services at the prices quoted in the Price Schedule below, in accordance with the conditions related thereto.

I/We agree to be bound by those terms and conditions in:

- the Standard Terms and Conditions for the Supply of Goods or Services to Transnet [Section 3 hereof]; and
- any other standard or special conditions mentioned and/or embodied in this Request for Quotation.

I/We accept that unless Transnet should otherwise decide and so inform me/us, this Quotation [and, if any, its covering letter and any subsequent exchange of correspondence], together with Transnet's acceptance thereof shall constitute a binding contract between Transnet and me/us.

I/We further agree that if, after I/we have been notified of the acceptance of my/our Quotation, I/we fail to deliver the said goods/service/s within the delivery lead-time quoted, Transnet may, without prejudice to any other legal remedy which it may have, cancel the order and recover from me/us any expenses incurred by Transnet in calling for Quotations afresh and/or having to accept any less favourable offer.

Price Schedule

I/We quote as follows for the Fabrication, Supply and Delivery of Galvanised Steel Columns and Beams for 19 Voortrekker Road, TRE Depot, Saltriver on an "as when required basis" for the period of 6 months prices excluding VAT:

REFER TO THE BILL OF QUANTITIES & TECHNICAL SPECIFICATION ATTACHED (ANNEXURE B)

Delivery Lead-Time from date of purchase order: _____ [days/weeks]

Notes to Pricing:

- a) All Prices must be quoted in South African Rand, exclusive of VAT
- b) To facilitate like-for-like comparison bidders must submit pricing strictly in accordance with this Bill of Quantities and not utilise a different format. Deviation from this Bill of Quantities could result in a bid being disqualified.
- c) Please note that should you have offered a discounted price(s), Transnet will only consider such price discount(s) in the final evaluation stage if offered on an unconditional basis.

Respondent's Signature

Date & Company Stamp

Section 3

STANDARD TERMS AND CONDITIONS FOR THE SUPPLY OF GOODS OR SERVICES TO TRANSNET

A Supplier/Service Provider shall be obliged to adhere to the Standard Terms and Conditions for the Supply of Goods and Services to Transnet as expressed hereunder. Should the Respondent find any condition(s) unacceptable, it should indicate which condition(s) is/are unacceptable and offer an alternative(s). A Quotation submitted by a Respondent will be subjected to review and acceptance or rejection of its proposed contractual terms and conditions by Transnet's Legal Counsel, prior to consideration for an award of business.

1 SOLE AGREEMENT

Unless otherwise agreed in writing, these terms [**Terms** and each **Term**] and Transnet's purchase order(s) [**Order** or **Orders**] represent the only conditions upon which Transnet SOC Ltd [**Transnet**] procures goods [**the Goods**] or services [**the Services**] specified in the Order from the person to whom the Order is addressed [**the Supplier/Service Provider**]. Transnet does not accept any other conditions which the Supplier/Service Provider may specify, unless otherwise agreed to by Transnet in writing. In the event of any inconsistency between these Terms and any Order, these Terms shall take precedence.

2 CONFORMITY WITH ORDER

Goods/Services shall conform strictly with the Order. The Supplier/Service Provider shall not vary the quantities specified and/or the specification, if any, stipulated in the Order, without the prior written consent of Transnet. The Supplier/Service Provider warrants that the Goods/Services shall be fit for their purpose and of satisfactory quality.

3 DELIVERY AND TITLE

- 3.1 The delivery dates and addresses are those in the Order. Time shall be of the essence in respect of the Supplier's/Service Provider's obligations under the Order.
- 3.2 The Supplier/Service Provider will not be excused for delay in delivery or performance except due to circumstances outside its control and then only subject to the Supplier/Service Provider having notified Transnet in writing on becoming aware of such circumstances. Transnet may terminate an Order, in whole or in part, without incurring any liability to the Supplier/Service Provider if such a delay becomes, in Transnet's absolute opinion, significant.
- 3.3 Risk of loss or damage to Goods shall pass to Transnet on delivery, and title shall pass to Transnet when payment to the Supplier for the Goods has been effected.
- 3.4 If on delivery, the Goods/Services do not conform to the Order, Transnet may reject the Goods/Services and the Supplier/Service Provider shall promptly rectify any defects or in Transnet's opinion, supply appropriate replacement Goods/Services at the Supplier's/Service Provider's expense within the specified delivery times, without any liability due by Transnet. Goods shall be subject to such testing and/or inspection as Transnet may consider necessary.

4 PRICE AND PAYMENT

- 4.1 Prices specified in an Order cannot be increased. Payment for the Goods/Services shall be made by Transnet against an original undisputed invoice(s) [a Tax Invoice], supporting documentation and month-end statement from the Supplier/Service Provider. Tax Invoices plus supporting documentation shall be posted to the address shown in the Order.
- 4.2 Payment of the Supplier's/Service Provider's valid Tax Invoice(s) will be made by Transnet in the South African currency and on the terms stated in the Order, the standard payment terms being 30 [thirty] days from date of receipt by Transnet of a month-end statement, unless otherwise agreed to in writing. Transnet shall arrange for payment of such Tax Invoices and any pre-authorised additional expenses incurred, provided that the authorised expenses are supported by acceptable documentary proof of expenditure incurred [where this is available]. Any amounts due in terms of these Terms shall be paid to the Supplier/Service Provider, taking into account any deduction or set-off and bank charges.

5 PROPRIETARY RIGHTS LIABILITY

If any allegations should be made or any claim asserted against Transnet that ownership of, or any act or omission by Transnet in relation to Goods/Services or any written material provided to Transnet relating to any Goods/Services or pursuant to an Order being a violation or infringement of any third party's contractual, industrial, commercial or intellectual property rights including but not limited to any patent, registered design, design right, trade mark, copyright or service mark on any application thereof, the Supplier/Service Provider hereby indemnifies Transnet against and hold it harmless from any and all losses, liabilities, costs, claims, damages and expenses [including any legal fees] arising directly or indirectly from such allegation or claim provided that this indemnity shall not apply where the allegation or claim arises solely as a result of the Supplier/Service Provider following a design or process originated and furnished by Transnet. The Supplier/Service Provider shall either

- a) procure for Transnet the right to continue using the infringing Goods; or
- b) modify or replace the Goods/Services so that they become non-infringing,

provided that in both cases the Goods/Services shall continue to meet Transnet's requirements and any specifications stipulated in the Order. Should neither option be possible, the Supplier/Service Provider may remove, with Transnet's prior written consent, such Goods/Services and will pay to Transnet a sum equivalent to the purchase price. If Transnet refuses to give such consent, the Supplier/Service Provider shall have no liability in respect of any continued use of the infringing Goods/Services after Supplier's/Service Provider's prior written request to remove the same.

6 PROPRIETARY INFORMATION

All information which Transnet has divulged or may divulge to the Supplier/Service Provider and any information relating to Transnet's business which may have come into the Supplier's/Service Provider's possession whilst carrying out an Order, and the existence of the Order, shall be treated by the Supplier/Service Provider as confidential information and shall not, without Transnet's prior written consent, be disclosed to any third party, or be used or copied for any purposes other than to perform the Order. This clause does not apply to information which is public knowledge or available from other sources other than by breach of this Term. Upon request by Transnet, the Supplier/Service Provider shall return all

materials issued pursuant to the Order and, pending this, shall protect Transnet's rights in any such materials. Such confidential information shall at all material times be the property of Transnet.

7 DEVELOPMENT WORK IN THE PRODUCTION OF GOODS

If the production or provision of any Goods involves research and/or development which are wholly or partly funded by Transnet, then all intellectual property or other rights as a result thereof shall be the property of Transnet on creation.

8 PUBLICITY

The Supplier/Service Provider shall not name Transnet or use its trademarks, service marks [whether registered or not] or Goods in connection with any publicity without Transnet's prior written consent.

9 AFTER SALES SERVICE

The Supplier shall provide replacement parts necessary to ensure the uninterrupted operation of the Goods supplied for the duration of the warranty period, from delivery of any particular item of the Goods and if requested by Transnet shall make these parts available to a third party maintainer of Transnet's choice at the same price as if the parts had been supplied to Transnet. The Supplier undertakes to provide a maintenance service for Goods, should Transnet so request, on terms to be agreed. If the Order so indicates, the Supplier will provide a warranty service for the Goods at a level to be agreed with Transnet.

10 TERMINATION OF ORDER

- 10.1 Transnet may cancel an Order in whole or in part at any time upon at least 7 [seven] days' written notice to the Supplier/Service Provider, or when there is a change in control of the Supplier/Service Provider or the Supplier/Service Provider commits any serious breach or any repeated or continued material breach of its obligations under these Terms and/or Order or shall have been guilty of conduct tending to bring itself into disrepute, on written notice to the Supplier/Service Provider when such work on the Order shall stop.
- 10.2 Transnet shall pay the Supplier/Service Provider a fair and reasonable price for justified work in progress, where such price reflects only those costs not otherwise recoverable by the Supplier/Service Provider, at the time of termination, and the Supplier/Service Provider shall give Transnet full assistance to check the extent of such work in progress. Payment of such price shall be in full and final satisfaction of any claims arising out of such termination and upon such payment the Supplier/Service Provider shall deliver to Transnet all work, including any materials, completed or in progress. The sum payable to the Supplier/Service Provider under this clause will not in any event exceed the total amount that would have been payable to the Supplier/Service Provider had the Order not been terminated.
- 10.3 In the event of termination the Supplier/Service Provider must submit all claims within 2 [two] months of termination after which time claims will only be met in what Transnet considers exceptional circumstances.
- 10.4 If the Goods or Services are not provided in accordance with an Order, the Order shall be deemed terminated and the Supplier/Service Provider shall compensate Transnet for any costs incurred in obtaining substitute Goods or any damage caused due to the failure or delay in the delivery.

11 ACCESS

The Supplier/Service Provider shall be liable for the acts, omissions and defaults of its personnel or agents who, for the purposes of the Order, shall be treated as if they are the Supplier's/Service Provider's employees. The Supplier/Service Provider shall ensure that any such personnel or agents, whilst on Transnet's premises, shall comply with Transnet's health and safety, security and system security rules and procedures as and where required.

12 WARRANTY

The Supplier/Service Provider warrants that it is competent to supply the Goods/Services in accordance with these Terms to the reasonable satisfaction of Transnet and that all Goods/Services delivered under the Order: (a) conform and comply in all relevant legislation, standards, directives and orders related to *[inter alia]* the supply, manufacture and use of the Goods/Services in force at the time of delivery, and to any specifications referred to in the Order; (b) will not cause any deterioration in the functionality of any Transnet equipment; and (c) do not infringe any third party rights of any kind. The Supplier/Service Provider hereby indemnifies Transnet against all losses, liabilities, costs, claims, damages, expenses and awards of any kinds incurred or made against Transnet in connection with any breach of this warranty.

13 INSOLVENCY

If the Supplier/Service Provider shall have a receiver, manager, administrator, liquidator or like person appointed over all or any part of its assets or if the Supplier/Service Provider compounds with its creditors or passes a resolution for the writing up or administration of the Supplier/Service Provider, Transnet is at liberty to terminate the Order or Orders forthwith, or at its option, to seek performance by any such appointed person.

14 ASSIGNMENT

The Supplier/Service Provider shall not assign its obligations under an Order without Transnet's prior written consent, which consent shall not be unreasonably withheld or delayed.

15 NOTICES

Notices under these Terms shall be delivered by hand to the relevant addresses of the parties in the Order or may be served by facsimile or by email, in which event notice shall be deemed served on acknowledgement of receipt by the recipient.

16 LAW

Orders shall be governed by and interpreted in accordance with South African law and any disputes arising herein shall be subject to South African arbitration under the rules of the Arbitration Foundation of South Africa, which rules are deemed incorporated by reference in this clause. The reference to arbitration shall not prevent Transnet referring the matter to any South African courts, having jurisdiction, to which the Supplier/Service Provider hereby irrevocably submits but without prejudice to Transnet's right to take proceedings against the Supplier/Service Provider in other jurisdictions and/or obtaining interim relief on an urgent basis from a court of competent jurisdiction pending the decision in other courts or from instituting in any court of competent jurisdiction any proceedings for an interdict or any other injunctive relief. If the Supplier/Service Provider does not have a registered office in the South Africa it will at all times maintain

an agent for service of process in South Africa and shall give Transnet the name and address of such agent as such may be amended, in writing, from time to time.

17 GENERAL

Completion or termination of an Order shall be without prejudice to any Term herein which by its nature would be deemed to continue after completion or termination, including but not limited to clauses. Headings are included herein for convenience only. If any Term herein be held illegal or unenforceable, the validity or enforceability of the remaining Terms shall not be affected. No failure or delay by Transnet to enforce any rights under these Terms will operate as a waiver thereof by Transnet. All rights and remedies available to either party under these Terms shall be in addition to, not to the exclusion of, rights otherwise available at law.

18 COUNTERPARTS

These Terms and conditions may be signed in any number of counterparts, all of which taken together shall constitute one and the same instrument. Any party may enter into this agreement by signing any such counterpart.

"PREVIEW COPY ONLY"

By signing this RFQ document, the Respondent is deemed to acknowledge that he/she has made himself/herself thoroughly familiar with all the conditions governing this RFQ, including those contained in any printed form stated to form part hereof and Transnet SOC Ltd will recognise no claim for relief based on an allegation that the Respondent overlooked any such condition or failed to properly take it into account for the purpose of calculating quoted prices or otherwise.

SIGNED at _____ on this ____ day of _____ 2014

.....
SIGNATURE OF RESPONDENT'S AUTHORISED REPRESENTATIVE

NAME: _____

DESIGNATION: _____

REGISTERED NAME OF COMPANY: _____

PHYSICAL ADDRESS:

Respondent's contact person: *[Please complete]*

Name :
Designation :
Telephone :
Cell Phone :
Facsimile :
Email :
Website :



**Transnet urges its clients, suppliers and the general public to report any fraud or corruption to
TIP-OFFS ANONYMOUS : 0800 003 056**

Respondent's Signature

Date & Company Stamp

Section 4
VENDOR APPLICATION FORM

Respondents are to furnish the following documentation and complete the Vendor Application Form below:

1. **Original** cancelled cheque **OR** letter from the Respondent's bank verifying banking details **[with bank stamp]**
2. **Certified** copy of Identity Document(s) of Shareholders/Directors/Members [where applicable]
3. **Certified copies** of the relevant company registration documents from Companies and Intellectual Property Commission (CIPC)
4. **Certified copies** of the company's shareholding/director's portfolio
5. A letter on the company's letterhead confirm physical and postal addresses
6. **Original** valid SARS Tax Clearance Certificate
7. **Certified copy** of VAT Registration Certificate
8. **A valid and original** B-BBEE Verification Certificate / sworn affidavit **or certified copy** thereof meeting the requirements for B-BBEE compliance as per the B-BBEE Codes of Good Practice
9. **Certified copy** of valid Company Registration Certificate [if applicable]

Vendor Application Form

Company trading name						
Company registered name						
Company Registration Number or ID Number if a Sole Proprietor						
Form of entity [v]	CC	Trust	Pty Ltd	Limited	Partnership	Sole Proprietor
VAT number [if registered]						
Company telephone number						
Company fax number						
Company email address						
Company website address						
Bank name			Branch & Branch code			
Account holder			Bank account number			
Postal address						

Respondent's Signature

Date & Company Stamp

			Code
Physical Address			Code
Contact person			
Designation			
Telephone			
Email			
Annual turnover range [last financial year]	< R5 m	R5 - 35 m	> R35 m
Does your company provide	Products	Services	Both
Area of delivery	National	Provincial	Local
Is your company a public or private entity	Public		Private
Does your company have a Tax Directive or IRP30 Certificate	Yes		No
Main product or services [e.g. Stationery/Consulting]			

Complete B-BBEE Ownership Details:

% Black ownership	% Black women ownership	% Disabled Black ownership	% Youth ownership
Does your entity have a B-BBEE certificate		Yes	No
What is your B-BBEE status [Level 1 to 9 / Unknown]			
How many personnel does the entity employ		Permanent	Part time

If you are an existing Vendor with Transnet please complete the following:

Transnet contact person	
Contact number	
Transnet Operating Division	

Duly authorised to sign for and on behalf of Company / Organisation:

Name		Designation	
Signature		Date	



ANNEXURE A: B-BBEE IMPROVEMENT PLAN

Transnet encourages its Suppliers/Service Providers to constantly strive to improve their B-BBEE rating. Whereas Respondents will be allocated points in terms of a preference point system based on its B-BBEE scorecard, in addition to such scoring, Transnet also requests that Respondents submit a B-BBEE improvement plan. Respondents are therefore requested to indicate the extent to which their ownership, management control, Supplier Development, Preferential Procurement and Enterprise Development will be maintained or improved over the contract period.

Respondents are requested to submit their B-BBEE Improvement Plan as an additional document with their Proposals.

Respondents are to insert their current status (%) and future targets (%) for the B-BBEE Improvement Plan [i.e. not the % change but the end-state quantum expressed as a percentage] in the table below. This will indicate how you intend to sustain or improve your B-BBEE rating over the contract period. On agreement, this will represent a binding commitment to the successful Respondent.

Transnet reserves the right to request supporting evidence to substantiate the commitments made in the B-BBEE Improvement Plan.

OWNERSHIP INDICATOR	Required Responses	Current Status (%)	Future Target (%)
1. The percentage of the business owned by Black ¹ persons.	<i>Provide a commitment based on the extent to which ownership in the hands of Black persons as a percentage of total ownership of the organisation would be sustained or increased over the contract period.</i>		
2. The percentage of your business owned by Black women.	<i>Provide a commitment based on the extent to which ownership in the hands of Black women as a percentage of total ownership of the organisation would be sustained or increased over the contract period.</i>		
3. The percentage of the business owned by Black youth ²	<i>Provide a commitment based on the extent to which ownership in the hands of Black youth as a percentage of total ownership of the organisation would be sustained or increased over the contract period.</i>		
4. The percentage of the business owned by Black persons living with disabilities	<i>Provide a commitment based on the extent to which ownership in the hands of Black disabled persons as a percentage of total ownership of the organisation would be sustained or increased over the contract period.</i>		
5. New Entrants ³ (Early stage business)	<i>Provide a commitment based on the extent to which new entrants will be supported over the contract period.</i>		

¹ "Black" means South African Blacks, Coloureds and Indians, as defined in the B-BBEE Act, 53 of 2003

² "Black youth" means Black persons from the age of 16 to 35

³ "New Entrants" means an early stage business which is similar to a start-up. However, an early stage business is typically 3 years old or less.

Respondent's Signature

Date & Company Stamp

MANAGEMENT CONTROL INDICATOR	Required Responses	Current Status (%)	Future Targets (%)
6. The percentage of Black Board members in relation to the total number of Board members	<i>Provide a commitment based on the extent to which the number of Black Board members, as a percentage of the total Board, would be sustained or increased over the contract period.</i>		
7. The percentage of Black female Board members in relation to the total number of Board members	<i>Provide a commitment based on the extent to which the number of Black female Board members, as a percentage of the total Board, would be sustained or increased over the contract period.</i>		
8. Black Executives directors as a percentage of all executive directors	<i>Provide a commitment based on the extent to which the number of Black executive Directors as a percentage of all Executive Directors would be sustained or increased over the contract period.</i>		
9. Black female Executives directors as a percentage of all executive directors	<i>Provide a commitment based on the extent to which the number of Black female executive Directors as a percentage of all Executive Directors would be sustained or increased over the contract period.</i>		
Other Executive Management	Required Response	Current Status (%)	Future Targets (%)
10. Black Executive Management as a percentage of all executive directors	<i>Provide a commitment based on the extent to which the number of Black executive Managers as a percentage of all Executive Directors would be sustained or increased over the contract period.</i>		
11. Black Female Executive Management as a percentage of all executive directors	<i>Provide a commitment based on the extent to which the number of Black female executive Managers as a percentage of all Executive Directors would be sustained or increased over the contract period.</i>		
Senior Management	Required Response	Current Status (%)	Future Targets (%)
12. Black employees in Senior Management as a percentage of all senior management	<i>Provide the percentage of Blacks that would be appointed or retained by the Board and would be operationally involved in the day to day senior management of the business, with individual responsibility for overall and/or financial management of the business and actively involved in the development and implementation of overall strategy, over the contract period.</i>		
13. Black female employees in Senior Management as a percentage of all senior management	<i>Provide the percentage of Black females that would be appointed or retained by the Board and would be operationally involved in the day to day senior management of the business, with individual responsibility for overall and/or financial management of the business and actively involved in the development and implementation of overall strategy, over the contract period.</i>		
Middle Management	Required Response	Current	Future

Respondent's Signature

Date & Company Stamp

		Status (%)	Targets (%)
14. Black employees in Middle Management as a percentage of all middle management	<i>Provide the percentage of Blacks that would be retained or appointed by the organisation in the middle management cadre and would be operationally involved in the day to day management of the business, with individual responsibility for a particular area within the business and actively involved in the day to day management of the organisation, over the contract period.</i>		
15. Black female employees in Middle Management as a percentage of all middle management	<i>Provide the percentage of Blacks females that would be retained or appointed by the organisation in the middle management cadre and would be operationally involved in the day to day management of the business, with individual responsibility for a particular area within the business and actively involved in the day to day management of the organisation, over the contract period.</i>		
Junior Management	Required Response	Current Status (%)	Future Targets (%)
16. Black employees in Junior management as a percentage of all junior management	<i>Provide a commitment based on the extent to which the number of Black Junior Managers as a percentage of the total junior Managers, would be sustained or increased over the contract period.</i>		
17. Black female employees in Junior management as a percentage of all junior management	<i>Provide a commitment based on the extent to which the number of Black female Junior Managers as a percentage of the total junior Managers, would be sustained or increased over the contract period.</i>		
Employees with disabilities	Required Response	Current Status (%)	Future Targets (%)
18. Black employees with disabilities as a percentage of all employees	<i>Provide a commitment based on the extent to which the percentage of Black disabled employees, in relation to the total of all employees in the organisation, would be sustained or increased over the contract period.</i>		
PREFERENTIAL PROCUREMENT INDICATOR	Required Responses	Current Status (%)	Future Targets (%)
19. B-BBEE procurement spend from all Empowering Suppliers ⁴ based on the B-BBEE procurement	<i>Provide a commitment based on the extent to which B-BBEE spend from all Empowering Suppliers would be sustained or increased over the contract period.</i>		

⁴ "Empowering Suppliers" means a B-BBEE compliant entity, which should meet at least three of the following criteria if it is a Large Enterprise or one if it is a QSE:

(a) At least 25% of cost of sales excluding labour cost and depreciation must be procured from local producers or local supplier in SA, for service industry labour cost are included but capped to 15%.

(b) Job creation - 50% of jobs created are for Black people provided that the number of Black employees since the immediate prior verified B-BBEE Measurement is maintained.

(c) At least 25% transformation of raw material/beneficiation which include local manufacturing, production and/or assembly, and/or packaging.

(d) Skills transfer - at least spend 12 days per annum of productivity deployed in assisting Black EMEs and QSEs beneficiaries to increase their operation or financial capacity.

recognition level as a percentage of total measured procurement spend			
20. 20 B-BBEE procurement spend from all Empowering Suppliers QSEs based on the applicable B-BBEE Procurement Recognition Levels as a percentage of Total Measured Procurement Spend	<i>Provide a commitment based on the extent to which B-BBEE spend from Empowering Supplier QSEs would be sustained or increased over the contract period</i>		
21. B-BBEE procurement spend from Exempted Micro-Enterprise based on the applicable B-BBEE procurement recognition Levels as a percentage of Total Measured Procurement Spend	<i>Provide a commitment based on the extent to which B-BBEE spend from EMEs would be sustained or increased over the contract period</i>		
22. B-BBEE procurement spend from Empowering Suppliers that are at least 51% black owned based on the applicable B-BBEE Procurement Recognition Levels as a percentage of Total Measured Procurement Spend	<i>Provide a commitment based on the extent to which spend from Empowering Suppliers who are more than 51% Black-owned would be maintained or increased over the contract period.</i>		
23. B-BBEE procurement spend from Empowering Suppliers that are at least 30% black women owned based on the applicable B-BBEE Procurement Recognition Levels as a percentage of Total Measured Procurement Spend	<i>Provide a commitment based on the extent to which spend from Empowering Suppliers who are more than 30% Black women-owned would be maintained or increased over the contract period.</i>		
24. B-BBEE Procurement Spent from Designated Group ⁵ Suppliers that are at least 51% Black owned	<i>Provide a commitment based on the extent to which spend from suppliers from Designated Group Suppliers that are at least 51% Black owned would be maintained or increased over the contract period.</i>		

"PREVIEW COPY ONLY"

⁵ "Designated Groups" means:

- a) unemployed black people not attending and required by law to attend an educational institution and not awaiting admission to an educational institution;
- b) black people who are youth as defined in the National Youth Commission Act of 1996;
- c) black people who are persons with disabilities as defined in the Codes of Good Practice on employment of people with disabilities issued under the Employment Equity Act;
- d) black people living in rural and under developed areas; and
- e) black military veterans who qualifies to be called a military veteran in terms of the Military Veterans Act 18 of 2011.

Respondent's Signature

Date & Company Stamp

SUPPLIER DEVELOPMENT INDICATOR	Required Response	Current Status (%)	Future Target (%)
25. Annual value of all Supplier Development ⁶ Contributions made by the Measured entity as a percentage of the target	<i>Provide a commitment based on the percentage in your organisation's annual spend on Supplier Development initiatives, will be maintained or improved over the contract period.</i>		
ENTERPRISE DEVELOPMENT INDICATOR	Required Response	Current Status (%)	Future Target (%)
26. The organisation's annual spend on Enterprise Development ⁷ as a percentage of Net Profit after Tax [NPAT]	<i>Provide a commitment based on the retention or increase in your organisation's annual spend on Enterprise Development initiatives, as a percentage of its Net Profit after Tax, over the contract period.</i>		

"PREVIEW COPY ONLY"

⁶ **"Supplier Development"** means monetary or non-monetary contributions carried out for the benefit of value-adding suppliers to the Measured Entity, with the objective of contributing to the development, sustainability and financial and operational independence of those beneficiaries:

(a) Supplier Development Contributions to suppliers that are Exempted Micro-Enterprises or Qualifying Small Enterprises which are at least 51% black owned or at least 51% black women owned.

Supplier Development within the context of the B-BBEE scorecard must be differentiated from Transnet's Supplier Development Initiatives. Whereas the former relates to the definition above, the latter relates to improving the socio-economic environment through initiatives that are committed to as part of a contract award that contribute to the development of a competitive supplier base in relation to a particular industry.

⁷ **"Enterprise Development"** means monetary and non-monetary contributions carried out for the following beneficiaries, with the objective of contributing to the development, sustainability and financial and operational independence of those beneficiaries:

(a) Enterprise Development Contributions to Exempted Micro-Enterprises or Qualifying Small Enterprises which are at least 51% Black owned or at least 51% Black women owned;

Respondent's Signature

Date & Company Stamp

ANNEXURE B

STRUCTURAL STEELWORKS FOR THE FIRE WATER RETICULATION INSTALLATION AT
TRANSNET RAIL ENGINEERING DEPOT AT SALT RIVER, CAPE TOWN

TECHNICAL SPECIFICATIONS, DRAWINGS AND BILL OF QUANTITY

TABLE OF CONTENTS	PAGE NO
PS1 SCOPE OF WORK	1
PS2 INTRERPRETATIONS	2
PSH STRUCTURAL STEELWORK	2
PSHC CORROSION PROTECTION	4
PS3 STRUCTURAL DRAWINGS AND SPECIFICATIONS	6
PS4 BILL OF QUANTITY	8

PS1 SCOPE OF WORK

This particular specification covers the fabrication and supply of structural steel works for the installation of the fire water reticulation at the Transnet Engineering Depot at Salt River, Cape Town and includes the following:

The preparation of shop drawings and the supplying of the Test Certificates, Material Certificates, Galvanizing Certificates, Welders Certificates and inspection certificates, supply, fabrication, galvanizing and delivering of all steel works to the precise position inside the TE Depot at Salt River (inclusive in the Bill of Quantity rates per unit) for the following steelwork items on an once off delivery for all the steel columns and once off delivery for all the steel beams:

1. All columns and beams, as per the drawing details on page 6 & 7 and technical specification given in this document and set out in the Bill of Quantity provided on page 8.
2. All columns to be 6 000 mm of height from the bottom of the base plate to the top of the column.
3. All columns to be fabricated and delivered to the precise position inside the TE Depot at Salt River where after TFR RME will fix these columns.
4. The Fabricator then needs to measure the precise lengths between the top of the columns for all the Beams to be fabricated as per details G & J on pages 6 & 7 and the Technical Specification and Bill f Quantity. The beams lengths as per the Bill of Quantity are rounded up lengths to the closes meter for tendering purpose. Payments for beam to be done as per the fabricate meter lengths and not the Bill of Quantity meters.
5. The fabricated beams then needs to be delivered to the precise position inside the TE Depot at Salt River where after TFR RME will fix these beams.

6. All documentation as set out above and as mentioned in the Bill of Quantity are to be inclusive in the column and beam rates.
7. Payment only to be done on complete delivery of all the columns, beams and documentation as requested.

The Fabricator shall supply a galvanizer's guarantee or test certificate prior to delivery. The Fabricator shall arrange for the coating application on fabricated steelwork to be inspected throughout by an independent competent person (hereinafter called the Inspector) appointed by the Fabricator. The appointment of the inspector shall be subject to the Engineer's approval.

And any work arising out of or incidental to the above, or required of the Contractor for the proper completion of the works in accordance with the true meaning and intent of the contract document.

PS2 INTERPRETATIONS

PS2.1 Supporting Specifications

In so far as they can be applied, and where they are not inconsistent with the terms of this Specification, the latest amendment of the relevant parts of SANS 1200 shall be regarded as being embodied in this Specification. The following list of Standard Specifications, not necessarily comprehensive, is referred to in this part of the Specifications:

SANS 2001-CS1: Construction works (Structural Steelwork)

SANS 1921-3: Construction and management requirements for works contracts (Structural Steelwork)

SANS 1200: Standardized specification for Civil Engineering construction

SANS 121 (ISO 1461): Hot dip galvanizing

SANS 1431: Weld able structural steel

SANS 10094: High-strength friction grip bolts

SANS 1700: Fasteners, Part 1 to Part 19

PS2.2 Abbreviations and Definitions

The abbreviations and definitions as described in the relevant Standard Specifications shall also be applicable to this Specification

PSH STRUCTURAL STEELWORK

PSH 1 SCOPE

SANS 1200 H, as amended below, shall apply to steel pipe supports and sundry structural steel items.

PSH 3 MATERIALS

PSH 3.1 STRUCTURAL STEEL

All steel used in the construction of these works shall comply with SANS 1431 Grade 350WA, or SANS 50025 Grade S355JR.

PSH 3.6 BOLTS, NUTS AND WASHERS

All bolts, nuts and washers shall be High Tensile Grade 8.8 and to be supplied as inclusive in the column and beam rates.

PSH 5 CONSTRUCTION

PSH 5.1 DRAWINGS AND SHOP DETAILS

PSH 5.1.2 Contractor Provides Shop Details

The Contractor shall be responsible for providing shop details in accordance with Clause PSH 5.1.2.

PSH 5.3 ASSEMBLY

PSH 5.3.4 Welding

(b) **WELDING TO BE CONTINUOUS:** All welding shall be continuous on all sides of any joint unless otherwise approved in writing by the Engineer. No crevices will be permitted and where stitch welding has been approved by the Engineer, the crevices so left shall be sealed with an approved filling compound prior to galvanising.

(c) **WELD APPEARANCE:** Welding shall be free of blowholes and all welding flux removed. All weld spatter and other sharp imperfections shall be removed prior to abrasive blasting. Prior to galvanising, weld beads with a surface irregularity exceeding 3 mm or with sharp crests having a radius less than 2 mm shall be ground. Weld grinding must not be performed on 304L or 316L stainless steel, however.

~~(d) **SITE WELDING:** Site welding shall be kept to a minimum and shall only be undertaken with the approval of the Engineer. Not Required.~~

PSH 7 TESTING

PSH 7.1 TEST CERTIFICATES

The structural steel fabricator shall obtain and submit to the Engineer certificates from all suppliers from whom steel is purchased stating that the material supplied conforms in all respects with SANS 1431 Grade 350WA or SANS 50025 Grade S355JR, as applicable.

PSH 8 MEASUREMENT AND PAYMENT

PSH 8.3 SCHEDULED ITEMS

PSH 8.3.14 Strut Supports

Strut supports shall be measured by number of each different type of Strut support as per the Bill of Quantity.

The rate per strut supports shall be an all-inclusive rate for supply, fabrication, corrosion protection, transport to site and handling and all as shown on the Drawings and/or specified.

Strut Supports, complete as shown on drawings and/or specified..... Unit: No

PSHC CORROSION PROTECTION

PSHC 1 SCOPE

This specification shall apply to the corrosion protection of strut support structures. The corrosion protection of pipework is specified in SANS 1200 L, as amended by Section PSL herein.

PSHC 5 CONSTRUCTION

PSHC 5.7 PAINTING SYSTEM

The coating system shall be as detailed on the drawings.

PSHC 5.9 APPLICATION OF METAL COATINGS

PSHC 5.9.1 Hot Dip Galvanizing (New Clause)

Hot dip galvanizing shall be done in accordance with SANS 121 and the following shall apply:

- (a) Coatings shall be to the thicknesses detailed in the Standard.
- (b) Hot dip galvanized material which is to remain unpainted shall be passivated as specified in SANS 121. Items to be painted after hot dip galvanizing shall be air dried and not passivated.
- (c) Hot dip galvanized material shall be substantially free of white rust when it is erected on site. Stacking and storing shall at all times be done in a manner to prevent white rust forming.
- (d) Damage to hot dip galvanizing caused by welding, grinding, etc. is not acceptable. Repair to hot dip galvanizing damaged by handling or transport shall be done by cleaning the area and applying 3 coats of a zinc rich primer giving a dry film thickness of at least 100 μm and containing at least 94% zinc in the dried film. If the Engineer considers that damage is excessive, such items shall be replaced by the Fabricator without cost at his own expense.
- (e) Welding after hot dip galvanizing is not acceptable.

The Fabricator shall supply a galvanizer's guarantee or test certificate prior to delivery.

PSHC 7 TESTING

PSHC 7.2 QUALITY CONTROL OF COATING APPLICATION

PSHC 7.2.1 Inspections (New Clause)

The Fabricator shall arrange for the coating application on fabricated steelwork to be inspected throughout by an independent competent person (hereinafter called the Inspector) appointed by the Fabricator. The appointment of the inspector shall be subject to the Engineer's approval. Inspections shall be adequate to ensure compliance with the Specification and shall be done at the following stages as a minimum:

PSHC 7.2.1.1 Coating (Hot Metal Spray, Paint, etc.)

- (a) After fabrication but before surface preparation.
- (b) After surface preparation but before application of the first coat.
- (c) After application of the final hot metal sprayed coating or after application of the paint primer or first coat (as applicable).
- (d) After the final factory applied paint or sealing coat.

PSHC 7.2.1.2 Hot dip Galvanizing

- (a) After fabrication but before hot dip galvanizing.
- (b) After hot dip galvanizing.

PSHC 7.2.1.2 Duplex Protection (Hot dip Galvanizing and Coating)

- (a) After fabrication but before hot dip galvanizing.
- (b) After hot dip galvanizing but before application of the first coat.
- (c) After application of the primer.
- (d) After the final Site applied paint coat.

PSHC 7.2.2 Witnessing of Inspection (New Clause)

If the coating is to be done in the Cape Peninsula by an inspector other than the Engineer, the Fabricator shall, nevertheless, arrange for the Engineer to witness the inspections at the latter's discretion.

PSHC 7.2.3 Inspection Report (New Clause)

A written report of the inspections, prepared by the Inspector and signed by both the Inspector and the Fabricator, shall be submitted for appraisal by the Engineer before delivery of the equipment to Site.

PSHC 7.2.4 Inspector Qualifications (New Clause)

Inspectors appointed by the Contractor shall hold an appropriate qualification from one of the following:

- (a) Corrosion Institute of Southern Africa.
- (b) South African Institute of Welding.
- (c) South African Institute for Non Destructive Testing.
- (d) South African Qualification and Certification Committee.

PSHC 7.2.5 Identification of Items (New Clause)

Every item to be coated shall be identified by a welded or hard stamped code. Records shall be maintained for each item.

PSHC 8 MEASUREMENT AND PAYMENT

PSHC 8.1 PRINCIPLES

The cost of corrosion protection as specified will be included in the relevant items for the supply and fabrication of steel pipe supports and pipe clamps.

PSHC 8.2 SCHEDULED ITEMS

PSHC 8.2.4 Inspections

A provisional sum will be scheduled for the employment of third party, independent inspector as required by Clause PSHC 7.2.1 above.

The Fabricator shall pay the Inspector all fees and costs due to him, which shall be recoverable under this item.

The Fabricator's tendered mark-up shall allow for profit, overheads and all administrative costs in appointing the Inspector and complying with associated requirements in respect of inspections of corrosion protection.

Employment of Independent Coatings Inspector PC Sum

PS3 STRUCTURAL DRAWINGS AND SPECIFICATIONS

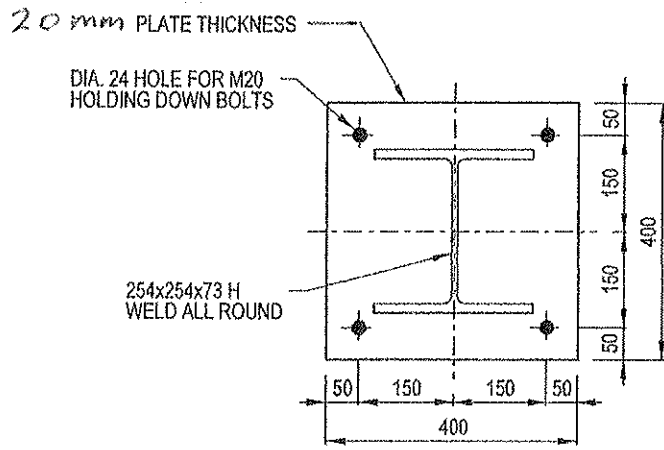

PLAN (6m Column & Base Plate)

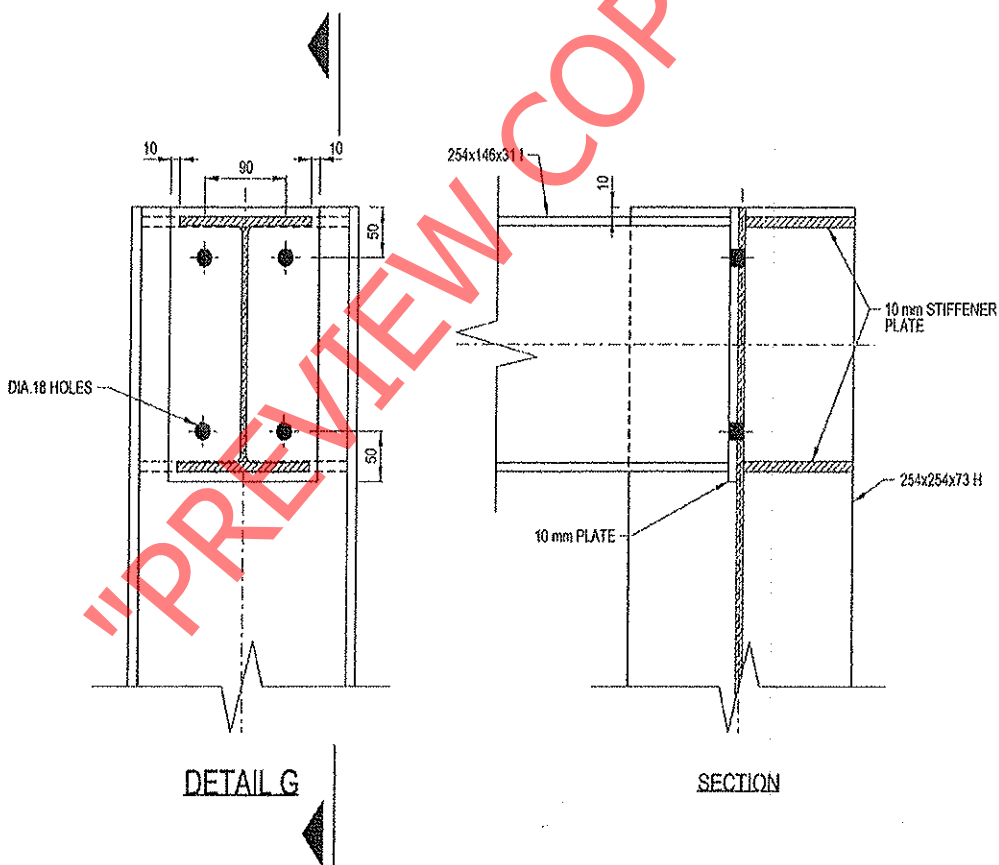

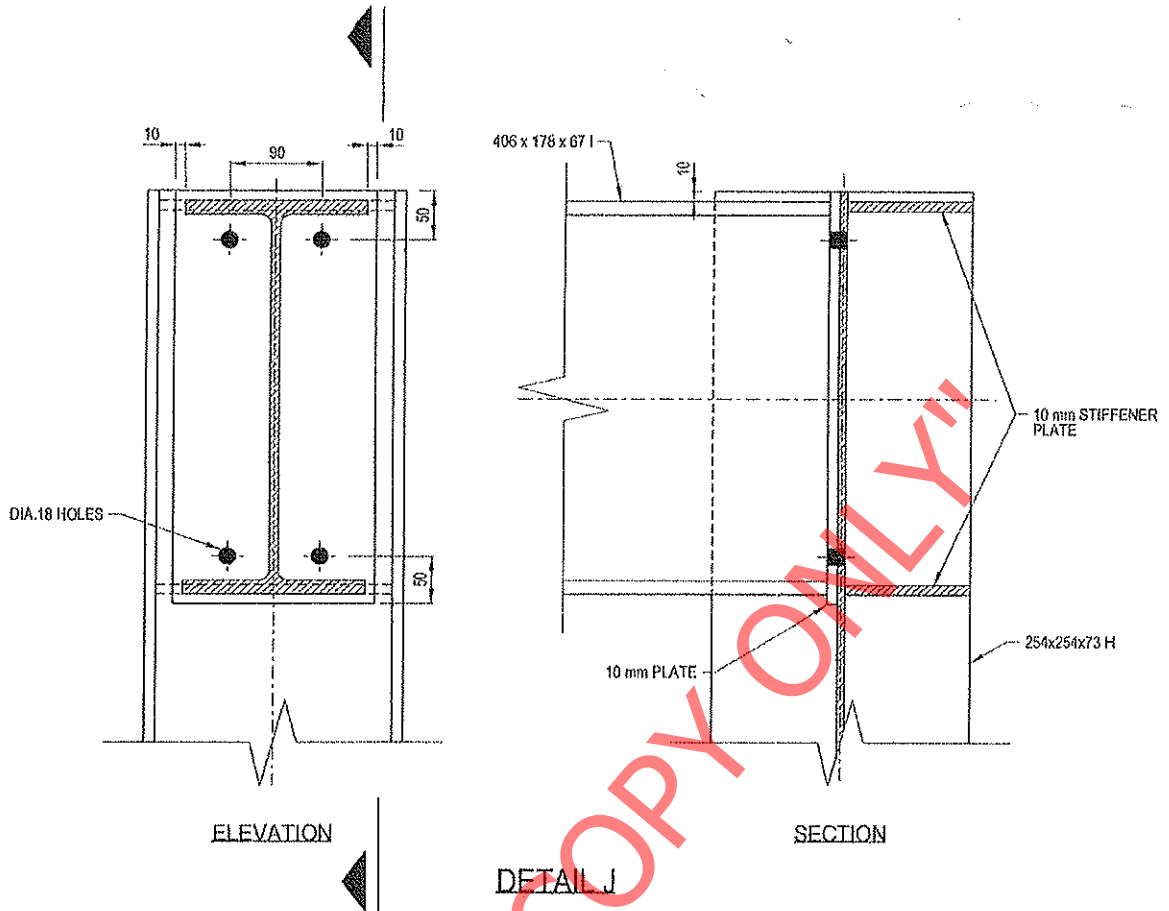

PS4 BILL OF QUANTITY

Item	Description	Unit	Quantity	Rate	Amount
1.0	254x254x73 H Columns @ 6m Lengths	EA	12		
2.0	254x146x31 I Beams (All 3 beams to be Measured On Site and use Detail G on page 6 to fabricate the beams, combined lengths to be less then 25 m.)	m	25		
3.0	406x178x67 I Beams (All 3 beams to be Measured On Site and use Detail J on page 7 to fabricate the beams, combined lengths to be less then 46 m.)	m	46		
4.0	Supplying of 100 number of M16 x 70 mm High Ten Sile Grade 8.8 (Black) Bolts, Nuts & Spring Washers (100 of each) and 200 number of Flat Washers.	Sum	Inclusive in the Rates Above		
5.0	Preparation of shop detail drawings, Supplying of Material-, Test-, Galvanising- and Welders Certificates.	Sum	Inclusive in the Rates Above		
6.0	Employment of an Independent Coatings Inspector and Supplying of the full Inspection Report as Specified.	PC SUM	1	-----	R 15 000.00

Nett Total (Excluding VAT) = R _____

"PREVIEW COPY ONLY"