

**TRANSNET**



*freight rail*

A Division of Transnet SOC Limited Registration number 1990/00900/30

# REQUEST FOR QUOTATION

**KBY/52846**

**KBY\_13707**

Senior Buyer  
Supply Chain Services  
TRANSNET FREIGHT RAIL  
Austen Street  
KIMBERLEY  
8301

**Transnet Freight Rail**, a division of

**TRANSNET SOC LTD**

Registration Number 1990/000900/30

[Hereinafter referred to as **Transnet**]

**REQUEST FOR QUOTATION [RFQ] No KBY/52846**

**FOR THE REPLACEMENT OF OLD 12V FLASH LIGHT SYSTEM WITH 24V FLASH LIGHT SYSTEM AT RIVERTON, FOR A PERIOD OF EIGHT (8) MONTHS.**

**FOR DELIVERY TO : TRANSNET FREIGHT RAIL, INFRA KIMBERLEY NORTH.**

**ISSUE DATE : 25 MARCH 2014**

**CLOSING DATE : 15 APRIL 2014**

**CLOSING TIME : 10:00**

"PREVIEW COPY ONLY"

**Section 1**  
**NOTICE TO BIDDERS**

---

Quotations which must be completed as indicated in Section 2 of this RFQ are to be submitted as follows:

**METHOD:** [Tender box or courier]  
**CLOSING VENUE:** [Tender box at physical address for hand delivery and courier:  
 Transnet Freight Rail, Property Management Building, Supply Chain  
 Services, Office no. 2, Austen Street, Beaconsfield]

---

**1 Responses to RFQ**

Responses to this RFQ [**Quotations**] must not include documents or reference relating to any other quotation or proposal. Any additional conditions must be embodied in an accompanying letter.

**2 Broad-Based Black Economic Empowerment [B-BBEE]**

Transnet fully endorses and supports the Government's Broad-Based Black Economic Empowerment Programme and it would therefore prefer to do business with local business enterprises who share these same values. Transnet will accordingly allow a "preference" to companies who provide a valid B-BBEE Verification Certificate. All procurement transactions will be evaluated accordingly.

**2.1 B-BBEE Scorecard and Rating**

As prescribed in terms of the Preferential Procurement Policy Framework Act (PPPFA), Act 5 of 2000 and its Regulations, Respondents are to note that the following preference point system is applicable to all bids:

- The 80/20 system for requirements with a Rand value of up to R1 000 000.00 (all applicable taxes included).
- Bidders are to note that if the 80/20 preference point system is stipulated in this RFQ and all Bids received exceed R1 000 000.00, the RFQ must be cancelled.

The value of this bid is estimated to be below R1000 000.00 (all applicable taxes included) and therefore the **80/20** system shall be applicable.

When Transnet invites prospective suppliers to submit Proposals for its various expenditure programmes, it requires Respondents to have their B-BBEE status verified in compliance with the Codes of Good Practice issued in terms of the Broad Based Black Economic Empowerment Act No. 53 of 2003.

The Department of Trade and Industry recently revised the Codes of Good Practice on 11 October 2013 [Government Gazette No. 36928]. The Revised Codes will replace the Black Economic Empowerment Codes of Good Practice issued on 9 February 2007. The Revised Codes provide for a one year transitional period starting 11 October 2013. During the transitional period, companies may elect to be measured in terms of the Revised Codes or the 2007 version of the Codes. After

the first year of the implementation of the Revised Codes, B-BBEE compliance will be measured in terms of the Revised Codes without any discretion. Companies which are governed by Sector-specific Codes will be measured in terms of those Sector Codes.

As such, Transnet will accept B-BBEE certificates issued based on the Revised Codes. Transnet will also continue to accept B-BBEE certificates issued in terms of the 2007 version of the Codes provided it was issued before 10 October 2014. Thereafter, Transnet will only accept B-BBEE certificates issued based on the Revised Codes.

Respondents are required to complete Annexure A [the B-BBEE Preference Point Claim Form] and submit it together with proof of their B-BBEE Status as stipulated in the Claim Form in order to obtain preference points for their B-BBEE status.

**Note: Failure to submit a valid and original B-BBEE certificate or a certified copy thereof at the Closing Date of this RFQ will result in a score of zero being allocated for B-BBEE.**

*[Refer clause 19 below for Returnable Documents required]*

## 2.2 B-BBEE Improvement Plan

Transnet encourages its Suppliers/Service Providers to constantly strive to improve their B-BBEE rating. Whereas Respondents will be allocated points in terms of a preference point system based on its B-BBEE scorecard to be assessed as detailed in paragraph 2.1 above, in addition to such scoring, Transnet also requests that Respondents submit a B-BBEE improvement plan. Respondents are therefore requested to indicate the extent to which they will maintain or improve their B-BBEE status over the contract period.

Respondents are requested to submit their B-BBEE Improvement Plan as an additional document with their Proposals by completion of **Annexure A** appended hereto. *[Refer to Annexure A for further instructions]*

### **Guidance Notes**

- *Note that for low value transactions, opportunities for B-BBEE Improvement are limited. Focus should be placed on longer term contracts.*

## 3 Communication

- a) Respondents are warned that a response will be liable for disqualification should any attempt be made by a Respondent either directly or indirectly to canvass any officer(s) or employee of Transnet in respect of this RFQ between the closing date and the date of the award of the business.
- b) A Respondent may, however, before the closing date and time, direct any written enquiries relating to the RFQ to the following Transnet employee:  
Name: Refilwe Ramothwala      Email: [Refilwe.Ramothwala@transnet.net](mailto:Refilwe.Ramothwala@transnet.net)
- c) Respondents may also, at any time after the closing date of the RFQ, communicate with Maggie Pain on any matter relating to its RFQ response:  
Telephone      053 838 3341      Email      [Maggie.Pain@transnet.net](mailto:Maggie.Pain@transnet.net)

The Respondent's original and valid Tax Clearance Certificate must accompany the Quotation. Note that no business shall be awarded to any Respondent whose tax matters have not been declared by SARS to be in order.

**4 VAT Registration**

The valid VAT registration number must be stated here: \_\_\_\_\_ [if applicable].

**5 Legal Compliance**

The successful Respondent shall be in full and complete compliance with any and all applicable national and local laws and regulations.

**6 Changes to Quotations**

Changes by the Respondent to its submission will not be considered after the closing date and time.

**7 Pricing**

All prices must be quoted in South African Rand on a fixed price basis, excluding VAT.

**8 Prices Subject to Confirmation**

Prices quoted which are subject to confirmation will not be considered.

**9 Negotiations**

Transnet reserves the right to undertake post-tender negotiations with selected Respondents or any number of short-listed Respondents.

**10 Binding Offer**

Any Quotation furnished pursuant to this Request shall be deemed to be an offer. Any exceptions to this statement must be clearly and specifically indicated.

**11 Disclaimers**

Transnet is not committed to any course of action as a result of its issuance of this RFQ and/or its receipt of a Quotation in response to it. Please note that Transnet reserves the right to:

- modify the RFQ's goods / service(s) and request Respondents to re-bid on any changes;
- reject any Quotation which does not conform to instructions and specifications which are detailed herein;
- disqualify Quotations submitted after the stated submission deadline;
- not necessarily accept the lowest priced Quotation;
- reject all Quotations, if it so decides;
- place an order in connection with this Quotation at any time after the RFQ's closing date;
- award only a portion of the proposed goods / service/s which are reflected in the scope of this RFQ;
- split the award of the order/s between more than one Supplier/Service Provider; or
- make no award at all.

**12 Transnet’s supplier integrity pact**

Transnet’s Integrity Pact requires a commitment from suppliers and Transnet that they will not engage in any corrupt and fraudulent practices, anti-competitive practices; and act in bad faith towards each other. The Integrity Pact also serves to communicate Transnet’s Gift Policy as well as the remedies available to Transnet where a Respondent contravenes any provision of the Integrity Pact.

Respondents are required to familiarise themselves with the contents of the Integrity Pact which is available on the Transnet Internet site [www.transnet.net/Tenders/Pages/default.aspx] or on request. Furthermore, Respondents are required to certify that they have acquainted themselves with all the documentation comprising the Transnet Integrity Pact and that they fully comply with all the terms and conditions stipulated in the Transnet Supplier Integrity Pact as follows:

|            |  |           |  |
|------------|--|-----------|--|
| <b>YES</b> |  | <b>NO</b> |  |
|------------|--|-----------|--|

Should a Respondent need to declare previous transgressions or a serious breach of law in the preceding 5 years as required by Annexure A to the Integrity Pact, such declaration must accompany the Respondent’s bid submission.

**13 Respondent’s Samples**

Respondents are required to submit samples of the Goods tendered for by it **only in cases where Transnet has specifically requested samples.** The sample(s) must be endorsed with the RFQ number and description and forwarded on or before the deadline date to the following addressee:

**N/A**

**14 Evaluation Criteria**

Transnet will utilise the following criteria [not necessarily in this order] in choosing a Supplier/Service Provider, if so required:

| <b>Criterion/Criteria</b>   | <b>Explanation</b>   |
|---|--|
| <b>Administrative responsiveness</b>  | Completeness of response and returnable documents  |
| <b>Substantive responsiveness</b>   | Prequalification criteria, if any, must be met and whether the Bid materially complies with the scope and/or specification given   |
| <b>Final weighted evaluation based on 80/20 preference point system as indicated in paragraph 2.1</b> | <ul style="list-style-type: none"> <li>Pricing and price basis [firm] - whilst not the sole factor for consideration, competitive pricing and overall level of unconditional discounts<sup>1</sup> will be critical</li> <li>B-BBEE status of company - Preference points will be awarded to a bidder for attaining the B-BBEE status level of contribution in accordance with the table indicated in Annexure A.</li> </ul> |

<sup>1</sup> Only unconditional discounts will be taken into account during evaluation. A discount which has been offered conditionally will, despite not being taken into account for evaluation purposes, be implemented when payment is effected.

**15 Validity Period**

Transnet desires a validity period of 30 [thirty] days from the closing date of this RFQ.

This RFQ is valid until \_\_\_\_\_.

**16 Banking Details**

BANK: \_\_\_\_\_

BRANCH NAME / CODE: \_\_\_\_\_

ACCOUNT HOLDER: \_\_\_\_\_

ACCOUNT NUMBER: \_\_\_\_\_

**17 Company Registration**

Registration number of company / C.C. \_\_\_\_\_

Registered name of company / C.C. \_\_\_\_\_

**18 Disclosure of Prices Quoted**

Respondents must indicate here whether Transnet may disclose their quoted prices and conditions to other Respondents:

YES  NO

**19 Returnable Documents**

**Returnable Documents** means all the documents, Sections and Annexures, as listed in the tables below.

- a) Respondents are required to submit with their Quotations the **Returnable Documents**, as detailed below.

***Failure to provide all these Returnable Documents at the Closing Date and time of this RFQ may result in a Respondent's disqualification. Respondents are therefore urged to ensure that all these Documents are returned with their Quotations.***

All Sections, as indicated in the footer of each page, must be signed, stamped and dated by the Respondent. Please confirm submission of these Returnable Documents by so indicating [Yes or No] in the table below:

| Returnable Documents   | Submitted<br>[Yes or No] |
|--|--------------------------|
| SECTION 1 : Notice to Bidders  |                          |
| - Valid and original B-BBEE Verification Certificate or certified copy thereof [Large Enterprises and QSEs]<br>Note: failure to provide a valid B-BBEE Verification Certificate at the closing date and time of the RFQ will result in an automatic score of zero for preference   |                          |
| - Valid and original B-BBEE certificate/sworn affidavit or certified copy thereof from auditor, accounting officer or SANAS accredited Verification Agency [EMEs]<br>Note: failure to provide a valid B-BBEE Verification Certificate at the closing date and time of the RFQ will result in an automatic score of zero being allocated for preference |                          |
| - In the case of Joint Ventures, a copy of the Joint Venture Agreement or written confirmation of the intention to enter into a Joint Venture Agreement  |                          |
| - Original valid Tax Clearance Certificate [Consortia / Joint Ventures must submit a separate Tax Clearance Certificate for each party]  |                          |
| SECTION 2 : Quotation Form   |                          |
| SECTION 3: Vendor Application Form   |                          |
| • Original cancelled cheque or bank verification of banking details  |                          |
| • Certified copies of IDs of shareholder/directors/members [as applicable]   |                          |
| • Certified copies of the relevant company registration documents from Companies and Intellectual Property Commission (CIPC)   |                          |
| • Certified copies of the company's shareholding/director's portfolio  |                          |
| • Entity's letterhead  |                          |
| • Certified copy of VAT Registration Certificate [RSA entities only]   |                          |
| • Certified copy of valid Company Registration Certificate [if applicable]   |                          |
| Financial Statements signed by your Accounting Officer or Audited Financial Statements for previous 3 years  |                          |
| ANNEXURE A – B-BBEE Preference Points Claim Form   |                          |

b) In addition to the requirements of paragraph a) above, Respondents are further requested to submit with their Proposals the following **additional documents** as detailed below.

Please confirm submission of these additional documents by so indicating [Yes or No] in the table below:

| Additional Documents                | SUBMITTED<br>[Yes or No] |
|-------------------------------------|--------------------------|
| ANNEXURE B: B-BBEE Improvement Plan |                          |



## Section 2 QUOTATION FORM

I/We \_\_\_\_\_  
hereby offer to supply the goods/services at the prices quoted in the Price Schedule below, in accordance with the conditions related thereto.

I/We agree to be bound by those terms and conditions in:

- the Standard Terms and Conditions for the Supply of Goods or Services to Transnet [available on request]; and
- any other standard or special conditions mentioned and/or embodied in this Request for Quotation.

I/We accept that unless Transnet should otherwise decide and so inform me/us, this Quotation [and, if any, its covering letter and any subsequent exchange of correspondence], together with Transnet's acceptance thereof shall constitute a binding contract between Transnet and me/us.

I/We further agree that if, after I/we have been notified of the acceptance of my/our Quotation, I/we fail to deliver the said goods/service/s within the delivery lead-time quoted, Transnet may, without prejudice to any other legal remedy which it may have, cancel the order and recover from me/us any expenses incurred by Transnet in calling for Quotations afresh and/or having to accept any less favourable offer.

### Price Schedule

I/We quote as follows for the goods required, on a "delivered nominated destination" basis, excluding VAT:

| Item No | Description of Goods /Services                                      | Total Price (ZAR) |
|---------|---|-------------------|
| 1.      | <b>Material for repair of interlocking</b>                          |                   |
| 2.      | <b>Cable laying, trenching and general labour</b>                   |                   |
| 3.      | <b>Pre-test and commissioning</b>                                   |                   |
| 4.      | <b>Plant and equipment(small)</b>                                   |                   |
| 5.      | <b>Plant and equipment(heavy duty)</b>                              |                   |
| 6.      | <b>Planning and design</b>  |                   |
| 7.      | <b>Installation</b>   |                   |
| 8.      | <b>Site establishment and security</b>                              |                   |
| 9.      | <b>Quality control, ISO 9001</b>                                    |                   |
| 10.     | <b>Preliminary and General(Accommodation, Transport and Labour)</b> |                   |
|         | <b>SUB TOTAL</b>  |                   |
|         | <b>VAT@14%</b>  |                   |
|         | <b>TOTAL</b>  |                   |

**Delivery Lead-Time from date of purchase order: \_\_\_\_\_ one (1) \_\_\_\_\_ [week]**

**Notes to Pricing:**

- a) All Prices must be quoted in South African Rand, exclusive of VAT
- b) To facilitate like-for-like comparison bidders must submit pricing strictly in accordance with this price schedule and not utilise a different format. Deviation from this pricing schedule could result in a bid being disqualified.
- c) Please note that should you have offered a discounted price(s), Transnet will only consider such price discount(s) in the final evaluation stage if offered on an unconditional basis.

## Section 3

**VENDOR APPLICATION FORM**

*Respondents are to furnish the following documentation and complete the Vendor Application Form below:*

1. **Original** cancelled cheque **OR** letter from the Respondent's bank verifying banking details **[with bank stamp]**
2. **Certified** copy of Identity Document(s) of Shareholders/Directors/Members [where applicable]
3. **Certified copies** of the relevant company registration documents from Companies and Intellectual Property Commission (CIPC)
4. **Certified copies** of the company's shareholding/director's portfolio
5. A letter on the company's letterhead confirm physical and postal addresses
6. **Original** valid SARS Tax Clearance Certificate
7. **Certified copy** of VAT Registration Certificate
8. **A valid and original** B-BBEE Verification Certificate / sworn affidavit **or certified copy** thereof meeting the requirements for B-BBEE compliance as per the B-BBEE Codes of Good Practice
9. **Certified copy** of valid C
10. Company Registration Certificate [if applicable]

## Supplier Declaration Form

|   |    |              |                         |                     |               |                               |  |
|---|----|--------------|-------------------------|---------------------|---------------|-------------------------------|--|
| Company Trading Name  |    |              |                         |                     |               |                               |  |
| Company Registered Name   |    |              |                         |                     |               |                               |  |
| Company Registration Number Or ID Number If A Sole Proprietor           |    |              |                         |                     |               |                               |  |
| Form of entity  | CC | Trust        | Pty Ltd                 | Limited             | Partnership   | Sole Proprietor               |  |
| VAT number (if registered)  |    |              |                         |                     |               |                               |  |
| Company Telephone Number  |    |              |                         |                     |               |                               |  |
| Company Fax Number  |    |              |                         |                     |               |                               |  |
| Company E-Mail Address  |    |              |                         |                     |               |                               |  |
| Company Website Address   |    |              |                         |                     |               |                               |  |
| Bank Name   |    |              |                         | Bank Account Number |               |                               |  |
| Postal Address  |    |              |                         |                     |               | Code                          |  |
| Physical Address  |    |              |                         |                     |               | Code                          |  |
| Contact Person  |    |              |                         |                     |               |                               |  |
| Designation   |    |              |                         |                     |               |                               |  |
| Telephone   |    |              |                         |                     |               |                               |  |
| Email   |    |              |                         |                     |               |                               |  |
| Annual Turnover Range (Last Financial Year)                             |    | < R5 Million |                         | R5-35 million       |               | > R35 million                 |  |
| Does Your Company Provide   |    | Products     |                         | Services            |               | Both                          |  |
| Area Of Delivery  |    | National     |                         | Provincial          |               | Local                         |  |
| Is Your Company A Public Or Private Entity                              |    |              |                         | Public              |               | Private                       |  |
| Does Your Company Have A Tax Directive Or IRP30 Certificate             |    |              |                         | Yes                 |               | No                            |  |
| Main Product Or Service Supplied (E.G.: Stationery/Consulting)          |    |              |                         |                     |               |                               |  |
| <b>BEE Ownership Details</b>  |    |              |                         |                     |               |                               |  |
| % Black Ownership   |    |              | % Black women ownership |                     |               | % Disabled person/s ownership |  |
| Does your company have a BEE certificate                                |    | Yes          |                         | No                  |               |                               |  |
| What is your broad based BEE status (Level 1 to 9 / Unknown)            |    |              |                         |                     |               |                               |  |
| How many personnel does the firm employ                                 |    | Permanent    |                         | Part time           |               |                               |  |
| Transnet Contact Person   |    |              |                         |                     |               |                               |  |
| Contact number  |    |              |                         |                     |               |                               |  |
| Transnet operating division   |    |              |                         |                     |               |                               |  |
| <b>Duly Authorised To Sign For And On Behalf Of Firm / Organisation</b> |    |              |                         |                     |               |                               |  |
| Name  |    |              |                         |                     | Designation   |                               |  |
| Signature   |    |              |                         |                     | Date          |                               |  |
| <b>Stamp And Signature Of Commissioner Of Oath</b>                      |    |              |                         |                     |               |                               |  |
| Name  |    |              |                         |                     | Date          |                               |  |
| Signature   |    |              |                         |                     | Telephone No. |                               |  |

**SPOORNET**

A Division of Transnet Limited

INFRASTRUCTURE (SIGNALS)

SPECIFICATION  
FOR

**TRENCHING AND OUTDOOR CABLE INSTALLATION**

**CONTENTS**

Page

|     |  |  |
|-----|--|--|
| 1.0 | SCOPE  |  |
| 2.0 | GENERAL  |  |
| 3.0 | TRENCHING  |  |
| 4.0 | HANDLING AND LAYING OF CABLE                         |  |
| 5.0 | BACKFILLING OF TRENCHES                              |  |
| 6.0 | CROSSINGS  |  |
| 7.0 | INSTALLATION OF STEEL-DUCTING AND CONCRETE TROUGHING |  |
| 8.0 | CABLE-JOINTING, JOINT-PITS AND MANHOLES              |  |
| 9.0 | INSTALLATION OF CABLE-MARKERS                        |  |

Drawn up by: Engineering Technician (Technology Management ): R. Prinsloo.. . . . .

Checked by: Sen. Eng. (Technology Management): B. Steyn . . . . .

Authorised by: Sen. Manager. (Technology Management): G. Paverd. . . . .

|  |                         |
|--|-------------------------|
| © This document as a whole is protected by copyright. The information contained herein is the sole property of Transnet Limited. It may not be used, disclosed or reproduced in part or in whole in any manner whatsoever, except with the written permission of and in a manner permitted by the proprietors. | Total No. of pages<br>8 |
|--|-------------------------|

- 3.5 Where the trench is being excavated in uneven ground, reasonably long sections of consistent grading shall be dug rather than following every undulation of the ground.
- 3.6 Trenching is not permitted up and down the slopes of banks or cuttings. In such cases, galvanised steel ducting must be used and the method adopted must be discussed and approved in writing by the Transport Services' Resident Engineer (Signals and Telecommunication).
- 3.7 The bottom of the trench shall be compacted and smooth with a view to obviating voids forming under the cable.
- 3.8 All outdoor cable shall be laid on sand, to be supplied by the sub-contractor, or approved soil passed through a 5mm riddle. The bottom of the trench shall thus be covered with a 50mm layer of sand or approved soil.
- 3.9 The sub-contractor shall be responsible for supplying and operating his own compressor plant for trenching and where blasting is required, he must make his own arrangements.
- 3.10 The sub-contractor's attention is drawn to the conditions pertaining to blasting as set out in clauses 24 and 25 of the E.5 (S and T) (1978) (Revised 1985) General Conditions of Contract.
- 3.11 Where trenches are excavated in rock, the sub-contractor shall dispose of the excavated material as directed by the Principal Contractor.

#### 4.0 HANDLING AND LAYING OF CABLE

- 4.1 Before the commencement of any cable-laying, the trench must be inspected and approved by the Engineer or his deputy.
- 4.2 It must be emphasised that special care shall be taken in handling of cables and under no circumstances must the cable be dragged or the PVC sheath damaged.
- 4.3 No direct laying will be permitted.
- 4.4 Cable shall not be laid in ash, unless it is surrounded at least by 300mm of sand or approved soil, and the trench depth is increased to 1050mm.
- 4.5 At each relay room, apparatus case or pothead location, 3 metres of cable slack must be provided.
- 4.6 If the apparatus case is not yet in position, the cable ends must be properly sealed, and then coiled and buried.

- 5.6 The minimum dry densities of backfilling after compaction are specified as:
- (a) Within the earthworks to provide the formation, both in bank and in cut, and on the formation and floor of cuttings: 1760 kilograms per cubic metre.
  - (b) In all other cases: 1600 kilograms per cubic metre.
- 5.7 Special care must be taken to avoid contamination of the ballast with soil.

## 6.0 CROSSINGS

- 6.1 Cables crossing culverts, bridges and rock formation shall be laid in galvanised piping, G.I. ducts or concrete troughs. Where piping is attached to a structure which is an electrical conductor such as steel, then the piping must be insulated from this structure by means of wooden cleats. Allowance must be made for expansion and contraction of pipes on bridges.
- 6.2 Cable passing through tunnels shall be placed in G.I. pipes or approved G.I. ducting with clip-on covers, when suitable cable ducts, let into the wall of the tunnel, are not provided. The minimum height shall be 1500mm from rail level.
- 6.3 As it is impossible at the site meeting to determine the quantity of crossings the pipe and/or ducting requirements should be worked out by the individual sub-contractors and submitted with their tenders.
- 6.4 Track crossings (Refer to drawing CSE.516/1 Annexure 2 Sheet 1)
- 6.4.1 All track crossings are to be made using pitch fibres to specification No. SABS 921 of 1969 and subsequent amendments or G.I. piping as specified in the main specification or at the site meeting. The length of pipe is approximately 4m per track to be crossed, i.e. the pipe must protrude beyond the edge of the ballast.
  - 6.4.2 Digging under the track, including shoring, as determined by the Engineer, is the Contractor's responsibility. This work will be supervised by the Engineer who will be responsible for strengthening the track where necessary and tamping the ballast after refilling.
  - 6.4.3 For track crossings, a minimum of two weeks notice must be given to

- 7.7 Joint boxes should be approximately double the width of the respective trough, and should be provided for all main troughing runs.
- 7.8 For the purpose of calculation of the quantity of joint boxes, it should be assumed that cables are supplied in drum lengths of 500m and 650m.
- 7.9 Concrete products damaged by the Contractor must be replaced by the Contractor.

8.0 CABLE-JOINTING, JOINT-PITS AND MANHOLES

- 8.1 Cable jointing shall be done by the Principal Contractor who must make every effort to complete the joints in time to allow the subcontractor to reclose jointing pits while backfilling. This however, cannot be guaranteed.
- 8.2 Joint-pits must be excavated from the main trench towards the track, and must be a semi-circle of 1,5m radius. (Refer to CSE.516/1 Annexure 1).
- 8.3 If used, manholes must be constructed of brickwork or cast concrete and waterproofed. Each shall be equipped with a concrete floor, a sump, steel rungs and suitable cover. Manholes shall not be smaller than 1m by 1m. The tenderer is to forward his proposal with his tender.

9.0 INSTALLATION OF CABLE-MARKERS (REFER TO DRAWING CSE.516/1 ANNEXURE 1 AND 2)

9.1 Concrete type

- 9.1.1 Within station limits the position of the main cable run shall be indicated by means of concrete cable markers. Cable markers shall be buried to a depth of approximately 250mm, so that  $\pm 50$ mm protrudes above the ground, and bearing the identification letters as per drawing ST.CCA.11-DF. They shall be installed at intervals of 15 metres on straight runs, and at every change of direction to cable markers at the angle of change shall be installed. Special designated cable markers bearing the marking "SI-X" (or latest amendment) shall be installed at every joint. See drawing No. ST.CCA.11-DF (latest amendment) for dimensions of cable markers.
- 9.1.2 Cable markers must be painted on the top and sides down to 150mm from the top, with two coats of yellow traffic paint
- 9.1.3 Joint markers must be painted as for cable markers.
- 9.1.4 All tail cable routes must be marked with concrete cable markers.

502AAF

SOUTH AFRICAN TRANSPORT SERVICES

ELECTRICAL SIGNALLING INSTALLATIONS

SPECIFICATION NO. CSE-516/1

JANUARY 1988

TRENCHING AND OUTDOOR CABLE INSTALLATION

- 1.0 SCOPE
- 2.0 GENERAL
- 3.0 TRENCHING
- 4.0 HANDLING AND LAYING OF CABLE
- 5.0 BACKFILLING OF TRENCHES
- 6.0 CROSSINGS
- 7.0 INSTALLATION OF STEEL- DUCTING AND CONCRETE TROUGHING
- 8.0 CABLE-JOINTING, JOINT-PITS AND MANHOLES
- 9.0 INSTALLATION OF CABLE-MARKERS



JANUARY 1988TRENCHING AND OUTDOOR CABLE INSTALLATION1.0 SCOPE

This specification covers the trenching for, and installation of, outdoor signalling cable. It does not include the jointing or termination of cables.

2.0 GENERAL

2.1 A proposed main cable route survey plan shall be submitted by the contractor and written approval obtained from the Engineer before any cables are laid.

2.2 Any deviations from the approved route must be agreed to in writing by the Engineer.

3.0 TRENCHING (REFER TO DRAWING CSE.516/1 ANNEX. 1)

3.1 The main cable trench shall be 4 m from the fence line. Attention is drawn to the fact that where there is an existing communication cable, this cable shall be within 2,5 metres from the fence unless indicated otherwise by cable markers.

Under no circumstances shall the cable trench be as the crow flies. All main or tail cable trenches must be at a straight line and any change of angle therefrom must be at 90°.

3.2 The depth of the trench shall be 500 mm minimum, unless otherwise specified. The depth of a trench, crossing a service road must be at 800 mm minimum.

3.3 Where a trench depth of 500 mm cannot be attained, the Engineer is empowered to authorise relaxation provided the cables are protected by a layer of reinforced concrete cover slabs and confirmation thereof has to be obtained in writing by means of an eligible site instruction.

The depth of all cable trenches on formations shall be at 500 mm depth and the cables must due to re-attain specified formation compaction be protected by a layer of reinforced concrete slabs.

These concrete cover slabs must be of a sufficient width to overlap the outside cables by at least 50 mm on either side. The minimum dimensions of these slabs shall be 40 mm thick, 300 mm wide and 500 mm long.

3.4 Where due to the terrain, trenching is not possible, the use of galvanised steel ducting and/or concrete troughs is permissible.

JANUARY 1988

- 3.5 Where the trench is being excavated in uneven ground, reasonably long sections of consistent grading shall be dug rather than following every undulation of the ground.
- 3.6 Trenching is not permitted up and down the slopes of banks or cuttings. In such cases, galvanised steel ducting must be used and the method adopted must be discussed and approved in writing by the Engineer.
- 3.7 The bottom of the trench shall be compacted and smooth with a view to obviating voids forming under the cable.
- 3.8 All outdoor cables shall be laid on sand, to be supplied by the contractor, or approved soil passed through a 5 mm riddle. The bottom of the trench shall thus be covered with a 50 mm layer of sand or approved soil.
- 3.9 The contractor shall be responsible for supplying and operating his own compressor plant for trenching and where blasting is required, he must make his own arrangements.
- 3.10 The contractor's attention is drawn to the conditions pertaining to blasting as set out in clauses 24 and 25 of the E.5(S & T) (1978) (Revised November 1987) General Conditions of Contract.
- 3.11 Where trenches are excavated in rock, the contractor shall dispose of the excavated material as directed by the Principal Contractor.

#### 4.0 HANDLING AND LAYING OF CABLE

- 4.1 Before the commencement of any cable-laying, the trench must be inspected and approved by the Engineer or his deputy.
- 4.2 It must be emphasised that special care shall be taken in handling of cables and under no circumstances must the cable be dragged or the PVC sheath damaged.
- 4.3 No direct laying will be permitted.
- 4.4 Cable shall not be layed in ash, unless it is surrounded at least by 300 mm of sand or approved soil, and the trench depth is increased to 1 050 mm .
- 4.5 At each relay room, apparatus case or pothead location, 3 metres of cable slack must be provided.

JANUARY 1988

- 4.6 If the apparatus case is not yet in position, the cable ends must be properly sealed, and then coiled and buried.
- 4.7 Each cable must be identified by a PVC, aluminium or lead strap which is tied around the cable at each end and which is inscribed with the cable size and number.
- 4.8 Where cables are to be jointed, 3 metres of overlap (1,5 metre per cable) must be provided.
- 5.0 BACKFILLING OF TRENCHES (REFER TO DRAWING CSE.516/1 ANNEX. 2 SHEET 2)
- 5.1 Before the commencement of any backfilling, and after cables have been laid, the trench must be inspected and approved by the Engineer or his deputy.
- 5.2 Should the contractor lay cable or backfill the trench without the inspection stipulated in clauses 4.1 and 5.1 having been conducted, the Transport Services reserves the right to request the contractor to re-open the trench and/or remove the cable, as the case may be, so that inspection may be carried out. Such re-opening of the trench and/or removal of the cable shall be for the contractor's account and he shall be liable for any damage done to the cable during the re-opening of the trench.
- 5.3 Backfilling must be preceded by the covering of the cables with a layer of sand or approved soil passed through a 5 mm riddle, to a minimum depth of 75 mm from the top of the cable. This material must be supplied by the contractor.
- 5.4 On completion of the laying of cables or pipes in trenches the latter shall be filled and compacted to the level of the ground or earthworks before trenching was commenced. When backfilling on the formation, an initial layer of 200 mm shall be compacted thereafter layers not exceeding 100 mm in loose thickness shall be compacted. Compaction shall be carried out by a mechanical rammer or other approved power tool to the minimum dry density hereinafter specified. Where necessary water shall be added to obtain the specified compacted density. Each layer shall be completed before the next layer is commenced. The contractor shall be responsible for ensuring that no damage is caused to the cable or pipes from the filling and compaction, and shall take such steps as are necessary to prevent any such damage, including the provision of concrete slabs or other approved means.

JANUARY 1988

- 5.5 The excavated material for the trenches may only be used for backfilling if it has an acceptably low amount of rock and stones in it, therefore, large stones shall not be used for backfilling.
- 5.6 The minimum dry densities of backfilling after compaction are specified as :
- (a) Within the earthworks to provide the formation, both in bank and in cut, and on the formation and floor of cuttings : 1 760 kilograms per cubic metre.
- (b) In all other cases : 1 600 kilograms per cubic metre.
- 5.7 Special care must be taken to avoid contamination of the ballast with soil.
- 5.8 When trenches are excavated on the formation, on the slopes of embankments, or on the slopes and floors of cuttings other than in rock, backfilling on the the trench will not obstructed or divert the natural water flow in such a way as to lead to erosion.
- Freedom from erosion of the trench itself an freedom from erosion caused by the trench must be guaranteed.
- 5.9 The replacement of made-up and concreted surfaces such as roads, pavements, platforms, etc., necessitated by trenching, must be arranged by the Contractor and the cost there included in his tender price.
- 5.9.1 In the case where the made-up surface consists of specially planted (hydroseeded) grass surfaces or/and grass soddings the hydroseeded surfaces are to be reseeded by the Contractor with seed mixtures as specified by Civil Department. Grass soddings is to be reinstated by the Contractor. The restoration of the made-up surface must be at the cost of the Contractor.

## 6.0 CROSSINGS

- 6.1 Cables crossing culverts, bridges and rock formation shall be laid in galvanised piping, G.I. ducts or concrete troughs. Where piping is attached to a structure which is an electrical conductor such as steel, then the piping must be insulated from this structure by means of wooden cleats. Allowance must be made for expansion and contraction of pipes on bridges.

JANUARY 1988

- 6.2 Cable passing through tunnels shall be placed in G.I. pipes or approved G.I. ducting with clip-on covers, when suitable cable ducts, let into the wall of the tunnel, are not provided. The minimum height shall be 1 500 mm from rail level.
- 6.3 As it is impossible at the site meeting to determine the quantity of crossings the pipe and/or ducting requirements should be worked out by the contractor and submitted with this tender.
- 6.4 Track crossings (Refer to drawing CSE.516/1 Annex. 2 Sheet 1)
- 6.4.1 All track crossings are to be made using pitch fibre pipes to specification No. SABS 921 of 1982 and subsequent amendments or G.I. piping as specified in the main specification or at the site meeting. The length of pipe is approximately 4 m per track to be crossed, i.e. the pipe must protrude beyond the edge of the ballast.
- 6.4.2 Digging under the track, including shoring, as determined by the Engineer, is the Contractor's responsibility. This work will be supervised by the Engineer who will be responsible for strengthening the track where necessary and tamping the ballast after refilling.
- 6.4.3 For track crossings, a minimum of two weeks notice must be given to the Engineer in advance for preparation to be effected.
- 6.5 Road crossings
- 6.5.1 Sufficient G.I. pipes must be provided at road crossings to cater for the cables to be installed. The total cross-sectional area of cables per pipe shall not exceed 60% of the cross-sectional area of the inside of the pipe.
- 6.5.2 For cables crossing under road :
- (a) Authority to dig must be obtained from the appropriate authorities by the Contractor.
  - (b) The trench must be at a depth of 800 mm .
  - (c) Minimum pipe size - 100 mm dia. G.I.
  - (d) At least one spare pipe must be provided.
  - (e) Cables crossing public roads shall be piped throughout where cable laid is not on Transport Services' property.

JANUARY 1988

6.5.3 Temporary roads must not be piped but slabbed.

6.5.4 All pipes to be surrounded by at least 50 mm of sand or approved soil.

7.0 INSTALLATION OF STEEL-DUCTING AND CONCRETE TROUGHING (REFER TO DRAWING CSE.516/1 ANNEX. 4)

7.1 Steel ducting installed on concrete or steel surfaces (as in tunnels, on bridges or culverts) must be firmly attached by an approved means.

7.2 In the case of slopes of banks or cuttings, the ducting must be firmly secured. The means of securing the ducting is subject to the approval of the Transport Services' Engineer in charge of the project (galvanised spike 1 m in length, concrete, etc.)

7.3 Concrete troughs (with lids) shall be in accordance with specification No. CSE-514 (latest amendment) and the relevant drawings.

7.4 Where troughing is laid alongside the track it shall be laid in such a manner so as not to prevent the placing or removal of sleepers from the track and must not obstruct civil maintenance.

7.5 Exit of cable from the main trough must be via the side of the trough and not underneath.

7.6 Reducing pieces for the transition from one size troughing to another should be designed along the lines of the troughing drawing provided.

7.7 Joint boxes should be approximately double the width of the respective trough, and should be provided for all main troughing runs.

7.8 For the purpose of calculation of the quantity of joint boxes, it should be assumed that cables are supplied in drum lengths of 500 m and 650 m .

8.0 CABLE-JOINTING, JOINT-PITS AND MANHOLES

8.1 Joint-pits must be excavated from the main trench towards the track, and must be a semi-circle of 1,5 m radius. (Refer to CSE.516/1 Annex. 1.)

8.2 If used, manholes must be constructed of brickwork or cast concrete and waterproofed. Each shall be equipped with a concrete floor, a sump, steel rungs and a suitable cover. Manholes shall not be smaller than 1 m by 1 m . The tenderer is to forward his proposal with his tender.

JANUARY 1988

9.0 INSTALLATION OF CABLE-MARKERS (REFER TO DRAWING CSE.516/1 ANNEXS. 1 AND 2)9.1 Concrete type

9.1.1 Within station limits the position of the the main cable run shall be indicated by means of concrete cable markers. Cable markers shall be buried to a depth of approximately 250 mm, so that + 50 mm protrudes above the ground, and bearing the identification letters as per drawing ST.CCA.11-DF. They shall be installed at intervals of 15 metres on straight runs, and at every change of direction to cable markers at the angle of change shall be installed. Special designating cable markers bearing the marking "SI-X" (or latest amendment) shall be installed at every joint. See drawing No. ST.CCA.11-DF (latest amendment) for dimensions of cable markers.

9.1.2 Cable markers must be painted on the top and sides down to 150 mm from the top, with two coats of yellow traffic paint.

9.1.3 Joint markers must be painted as for cable markers.

9.1.4 All tail cable routes must be marked with concrete cable markers.

9.2 Metal (fence) type (Refer to drawing CSE.516/1 Annexs. 1 and 3)

9.2.1 These are to be installed outside station limits or where it is not practicable to install concrete markers.

9.2.2 Main cable route :

Fence markers painted yellow (paint must withstand field fires; HD cedar Radex paint or similar) and affixed securely to the fence uprights every 15 metres, must be used. If for any reason the cable route is shifted from the specified distance of 4 m from the fence line this must be indicated on the fence markers by punching the actual distance of the cable route from the fence. In addition the main cable route outside the servitude must be marked by means of special markers (pipes, rails etc.) painted yellow with approved paint. The fence markers shall be made from a suitable metal, of sufficient thickness (+2 mm) to ensure

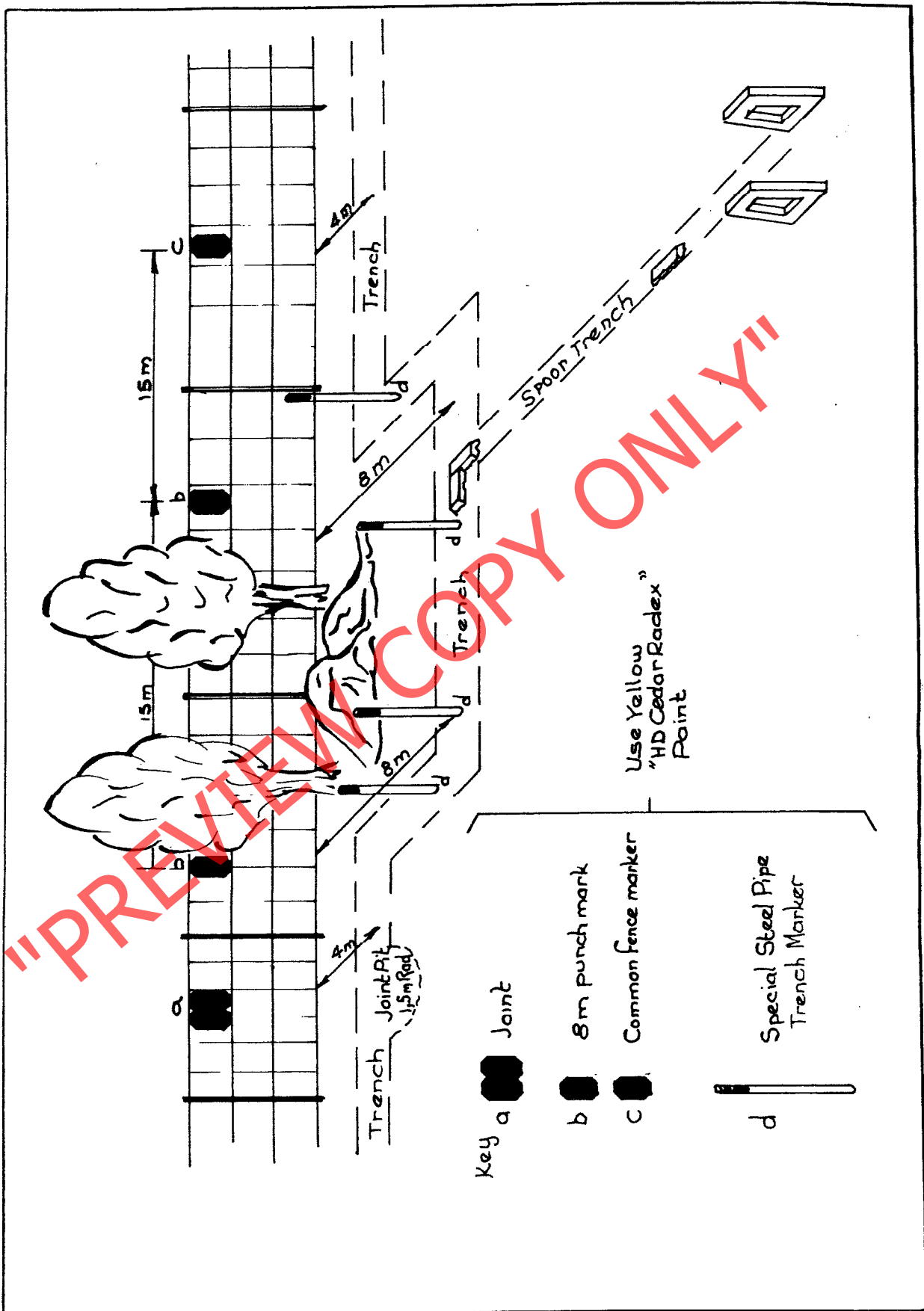

- Key
- a Joint
  - b 8m punch mark
  - c Common fence marker
  - d Special Steel Pipe Trench Marker

Use Yellow  
"HD Cedar Radex"  
Paint

SATS ~ SAVD  
TYPICAL CABLE TRENCH

| SPECIFICATIONS      |
|---------------------|
| CE (S&T)            |
| 516/1               |
| Annexure 1 OF VNN 4 |



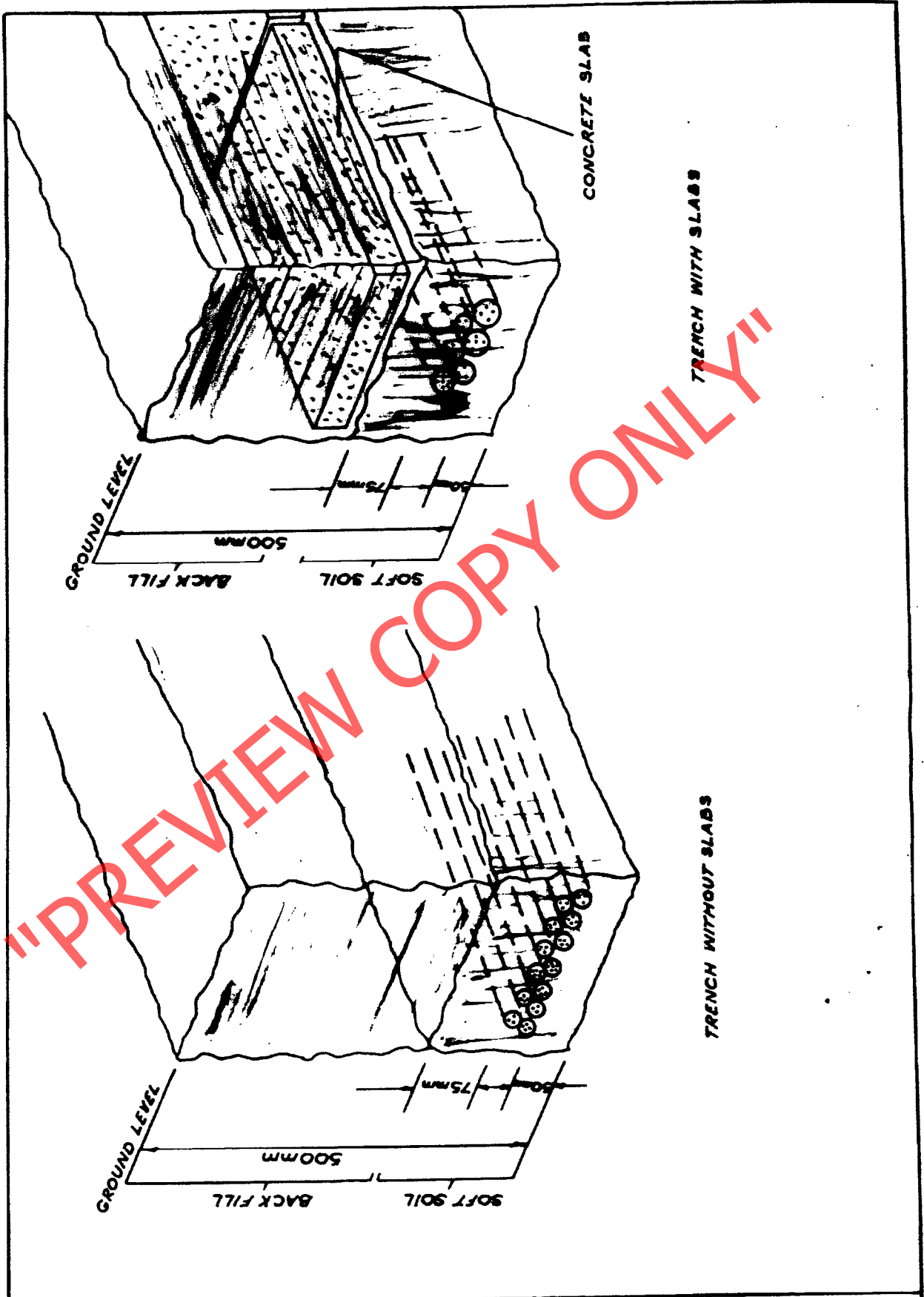

"PREVIEW COPY ONLY"

SATS ~ SAVD

TRENCH CROSS SECTION

SPECIFICATIONS

CE(S&T)

SIG/1

ANNEXURE 2 <sup>SAT</sup> 2 <sup>OF</sup> 4 <sub>REL</sub>

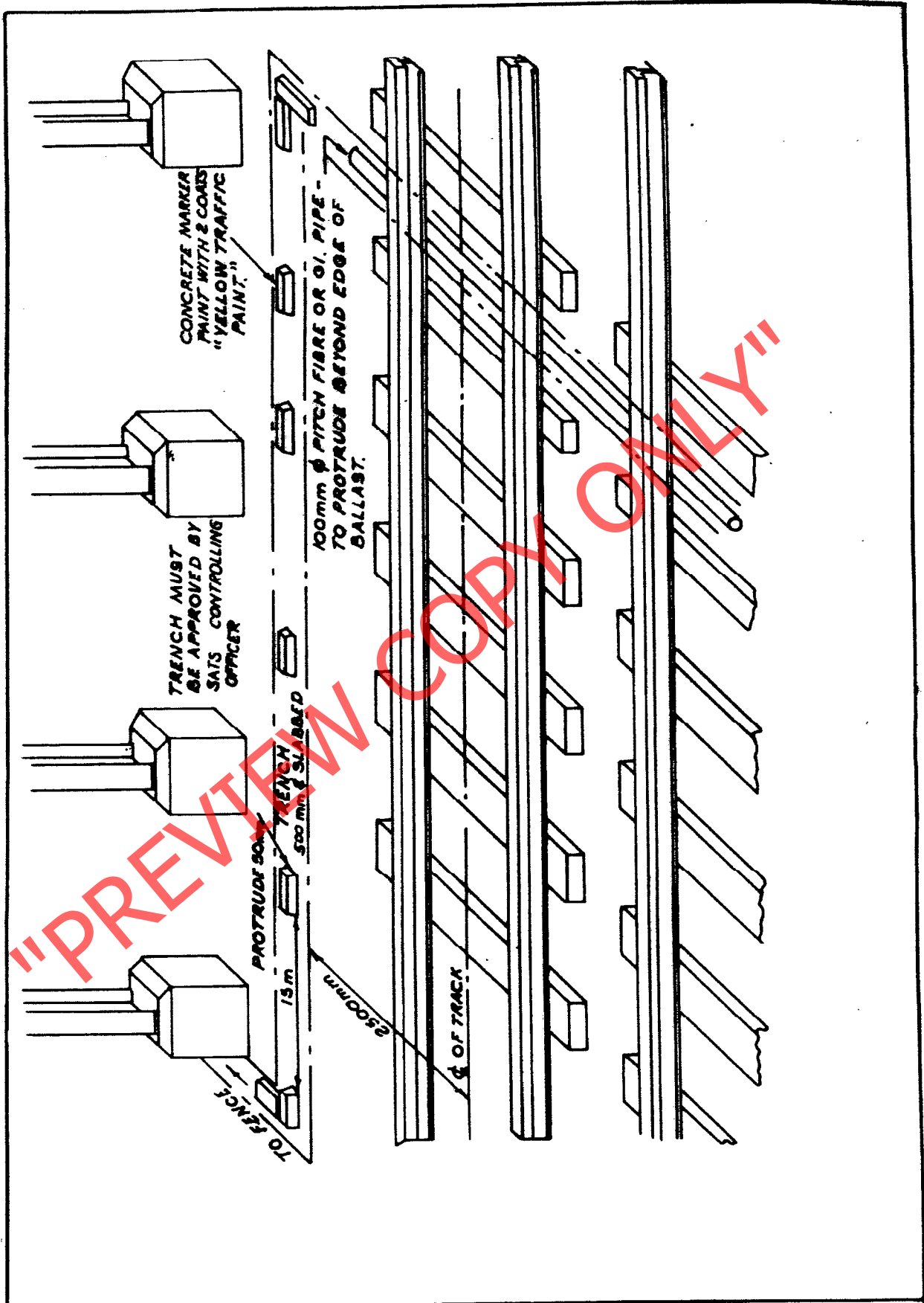

SATS ~ SAVD

TRENCH PARALLEL TO TRACK AND TRACK CROSSING

SPECIFICATION

CE (S&T)

SIG/1

ANNEXURE 2 SHE. 1 OF 2

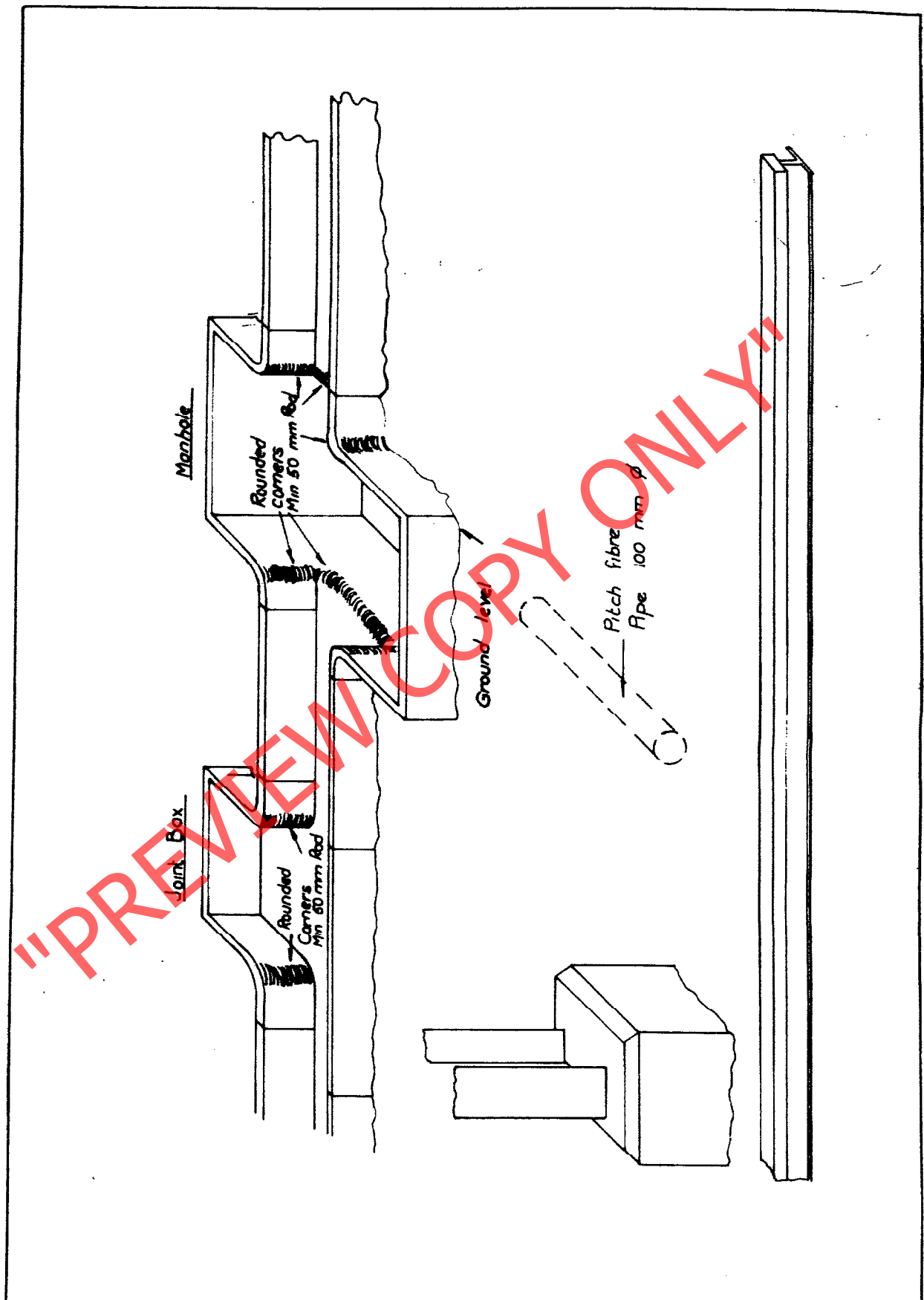

SATS ~ SAVD

INSTALLATION OF CONCRETE TROUGHING

26

SPECIFICATION

CE (S&T)

SIG/1

Annexure 4 OF VAN 4

**SPOORNET**

A Division of Transnet Limited

INFRASTRUCTURE (SIGNALS)

SPECIFICATION  
FOR

INSTALLATION OF EARTHING

**CONTENTS**

|                                   | Page |
|-----------------------------------|------|
| 1. SCOPE                          | 2    |
| 2. APPLICABLE DOCUMENTS           | 2    |
| 3. TYPES OF EARTHS                | 2    |
| 4. RELAY ROOMS                    | 3    |
| 5. HOUSINGS OUTSIDE RELAY ROOMS   | 5    |
| 6. TRACK CIRCUITS                 | 5    |
| 7. SIGNALS                        | 5    |
| 8. POINTS MACHINES                | 5    |
| 9. SIGNALLING CABLES              | 6    |
| 10. CTC CABLE AND EQUIPMENT       | 6    |
| 11. EARTHING IN AC TRACTION AREAS | 6    |
| 12. APPENDIX                      | 7-16 |

PREVIEW COPY ONLY

Drawn up by: Engineering Technician (Technology Management): R. Prinsloo.....  
....

Checked by: Sen. Eng. (Technology Management): B. Steyn .....

Authorised by: Sen. Manager. (Technology Management): G. Paverd. ....

|  |                                       |
|--|---------------------------------------|
| © This document as a whole is protected by copyright. The information contained herein is the sole property of Transnet Limited. It may not be used, disclosed or reproduced in part or in whole in any manner whatsoever, except with the written permission of and in a manner permitted by the proprietors. | Total<br>No. of<br>pages<br><b>16</b> |
|--|---------------------------------------|

Circulation Restriction: Transnet and Relevant Third Parties

- 1.1 This specification sets out the requirements and procedure to be followed for the earthing of signalling equipment. It aims to protect personnel against hazardous working conditions, damaging of equipment, electric stress caused by lightning and to ensure the generation of sufficient fault currents to trigger protective devices.

## 2 APPLICABLE DOCUMENTS

- 2.1 Drawing CSE-Z-462 CAT.N28. Typical relay room earth layout.  
2.2 Specification CSE-1164-066 CAT.X47. Stranded, bare copper or pvc insulated cable for earth connections.  
2.3 "Safety instructions: High Voltage equipment" as issued by the Chief Engineer (Electrical).  
2.4 Investigation report CSE-1123-038 CAT.E97. Investigation report on earthing of relay rooms.  
2.5 Drawing CSE-1155-515 CAT.N28 sheet 1-4.  
2.6 CSE Z148 (Signalling standard series).

## 3 TYPES OF EARTH

### 3.1 Trench Earth (Refer to Appendix 4)

- 3.1.1 Two lengths of 16 mm<sup>2</sup> bare copper cable (according to specification CSE-1164-066) shall be laid next to each other in a trench separated by the width of the trench.
- 3.1.2 The minimum depth at which the earth conductor shall be laid is 450 mm below normal ground level.
- 3.1.3 The total length of the trench earth conductor shall not be less than 50 m nor exceed 80 m.
- 3.1.4 To minimize the effects of electrolytic corrosion on the earth conductors in DC traction areas the trench shall be at right angles to the track and at least 10 m away from the track. The bare earth conductor shall be connected to the apparatus by means of unarmoured insulated 16 mm<sup>2</sup> copper cable (see specification CSE-1164-066). The length of this cable shall not be less than 15 m nor exceeding 50 m.
- 3.1.5 The earth wire shall be surrounded by 50 mm of approved virgin soil. Thereafter normal backfill free of large stones may be used.

### 3.2 Vertical Electrode Earth

- 3.2.1 Vertical earth electrodes shall be driven into the ground to a depth of at least 4 metres.
- 3.2.2 Where the required resistance is not obtained, multiple vertical electrodes shall be used. The rods shall be spaced at 3 m intervals.
- 3.2.3 Bimetallic copper/steel rods shall be used as earth electrodes. The rods shall be constructed by a molten welded process resulting in the formation of a microscopic crystalline steel alloy between the two metals. Electroplated rods shall not be used.

- 3.2.4 Where mechanical hammers are used to drive the rods, a suitable adaptor shall be used to ensure that the point of percussion is in a direct line with the central axis of the rod.
- 3.2.5 A phosphor bronze clamp designed to fit the rod and to incorporate the interconnecting wire shall be used for connection. All connections to electrodes shall be made 500mm under the ground surface using unarmoured insulated copper conductor to the earth electrode.
- 3.2.6 In the event of dissimilar metals, such as aluminium which are used for lightning protection, the connection between the dissimilar metals shall be made above ground and the joint shall be tinned, double rivetted and rendered watertight.

### 3.3 Combined Horizontal and Vertical Earth Electrode Systems

- 3.3.1 The trench earth system may be combined with the vertical earth electrode system by driving single vertical rods, one metre in length, connected in parallel to the horizontal earth. These vertical rods shall be spaced a minimum of one metre apart.

### 3.4 Ring Earth

- 3.4.1 The earthing ring shall consist of bare copper conductor of at least 16 mm<sup>2</sup> cross-sectional area. The ring shall have a radius of at least 1.5 metres.

### 3.5 General

- 3.5.1 An earthing system may be placed up to 50 metres from the apparatus to be protected.
- 3.5.2 Low-lying and/or damp areas must be selected in preference to high or dry localities.
- 3.5.3 Wherever possible, virgin soil must be used for earthing and soil such as those used for railway embankments must be avoided.
- 3.5.4 Areas in the vicinity of trees must be avoided as far as possible because the moisture content of such areas is greatly reduced by the water absorbed by the trees.
- 3.5.5 The vertical earth electrode system is preferred.
- 3.5.6 All earth wires and cables must be as straight as possible. Kinks, coils and sharp bends must be avoided to minimise surge impedance.

## 4 RELAY ROOMS

- 4.1 Every relay room shall have a separate Signal earth. This earth shall have a ground resistance of less than 1Ω and shall be one of the types as described in paragraph 3 of this document.
- 4.2 An earth busbar shall be provided in the signalling power cubicle (power cubicle earth busbar),

on the outgoing panel (outgoing panel earth busbar) and on the interlocking (interlocking earth busbar) as shown in Appendices 1 and 2 of this document.

4.3 The connection between earth busbars and/or the signal earth shall be an insulated copper cable with a cross sectional area of at least  $16\text{mm}^2$  and shall conform to specification CSE-1164-066 CAT.X47. The colour of the insulation of the cable used for wiring of all the earth connections to the various equipment shall be of the green and yellow type.

4.4 All metal structures of the equipment in the relay room shall be isolated from the building.

4.5 All exposed metallic surfaces (interlocking racks, cable trays etc. ) not normally carrying current shall be coupled to an earth busbar.

4.6 All the earth terminals of power equipment shall be wired individually to the power cubicle earth busbar (See drawing CSE Z 462 in Appendix 1).

4.7 The earth busbar provided by the EL&P department in the distribution box (relay room ) shall be coupled to the power cubicle earth busbar or the outgoing panel earth busbar , whichever is the shortest connection.

4.8 The armouring of supply cables between the EL&P distribution box and the power cubicle shall be earthed at both sides to the corresponding earth busbar as shown in Appendix 5.

4.9 The armouring of outgoing cables shall be connected to the earth busbar at the relay room end. Pig tail connections from the cable's armouring shall be connected separately to enable each cable to be isolated individually when an earth fault is traced as shown in Appendix 5.

4.10 The Neutral of 440V feeds shall not be earthed.

4.11 All cable trays shall be electrically isolated from the rack structures and separately connected to the interlocking earth busbar by a removable earth jumper.

4.12 The connection of equipment to any of the Earth busbars shall be such that any part of equipment can be isolated from the earth busbars without disturbing the earth connection of other equipment.

4.13 A removable earth jumper shall be provided between the interlocking earth busbar and the metal structure of each row of the interlocking as shown on drawings in Appendices 1 and 2.

4.14 Assembly of racks should be such that racks in the same row are permanently in good electrical contact with each other . (Star washers, earth jumpers, pig tail connections, etc.) See drawing in Appendix 2.

4.15 Any lightning protection done on incoming and/or outgoing circuits shall be coupled to the nearest earth busbar.

4.16 The sub-rack earth of any electronic/electrical equipment ( PLC, Relay housings, Remote

control, Axle counters etc.) shall be individually connected to its resident rack's metal structure.

4.17 The maximum resistance between the signal earth connection and any metal structure in the relay room not normally carrying current shall be less than  $0.1\Omega$ .

4.18 All earth connections shall have a minimum DC current carrying capability of 10 A.

4.19 A circuit in the book of circuits of the installation showing all earth connections shall be provided (similar to CSE Z 462 in Appendix 1).

4.20 Any modifications involving the earth and/or earth connections shall be updated on the drawing in the book of circuits containing the earth connections.

## 5 HOUSINGS OUTSIDE RELAY ROOMS

(Refer to Appendices 4 and 5)

5.1 Cases such as apparatus cases, potheads, hot box detector housings, etc. outside relay rooms, shall be earthed at ground level, NOT formation level. Should cases be constructed of a non-conducting material, then any metal framework in or outside the case shall be earthed. Signal transformer cases housing equipment operating in excess of 150V shall be earthed. See page 75 of "Safety instructions: High Voltage Equipment 1992" as issued by the Chief Engineer (Electrical), Infrastructure, Spoornet. An earth value of less than  $10\Omega$  must be obtained.

5.2 The end of the earthing wire which is to be fixed to the apparatus shall be compression crimped or soldered into a lug big enough to take all strands of the earthing wire, the lug being fixed by a clean bolt of non-corrosive material onto a clean metallic surface and sealed against corrosion.

5.3 Ducting (outside or in tunnels), trackside disconnection boxes, signal transformers, mounting posts and cases, which are used for housing equipment operating at less than 150 V shall not be deliberately earthed nor shall they be bonded to the return rail.

## 6 TRACK CIRCUITS

6.1 All track circuits must be equipped with lightning arresters and earthed in accordance with the manufacturer's recommendations and the requirements of Transnet as in CSE Z148 series.

## 7 SIGNALS

7.1 **DC and 25KV AC electrified lines.**  
Signals shall not be earthed or connected to the return rail.

7.2 **50KV AC electrified lines.**  
Signals on these lines shall be earthed by means of a trench earth or by a ring earth.



## 8 POINTS MACHINES

8.1 Points machines shall not be earthed or connected to the return rail.

## 9 SIGNALLING CABLES (Refer to Appendix 5)

9.1 In the relay room the armouring of main signalling cables shall be earthed. In DC traction areas the armouring of these cables at the apparatus case shall not be earthed and shall be properly insulated with shrink sleeving as shown in Appendix 5.

9.2 The armouring of 440 V power cables in DC traction areas shall be earthed at the relay room end and at the start of each subsequent termination point. In AC traction areas the armouring of 440V power cables shall be earthed at both sides.

9.3 Tail cables (i.e. apparatus case/points pothead to final function, e.g. signal, points disconnection box, trackside disconnection box, etc.) shall not have their armouring earthed at either end. The armouring of all tail cables must be cut back and properly insulated, e.g. with shrink sleeving.

## 10 CTC CABLE AND EQUIPMENT

10.1 All lightning arresters shall be mounted as close as possible to the cable entry and all connections to the arresters shall be as short and straight as possible.

Full details of protection against lightning, proposed type of arresters to be used, etc., must be submitted with any quotation for CTC cables and equipment. See CSE Z148 series.

## 11 EARTHING IN AC TRACTION AREAS

11.1 The earthing procedures shall be modified in AC traction areas as set out below:

11.1.1 No signal equipment or structure to which any cable armouring is connected and earthed by means of trench earth shall be closer than 2,5 m to the centre line of any electrified track. This shall be measured from the nearest possible extremity of the equipment to the centre line of the track. In the case of equipment with hinged doors, this is to be measured with the doors closed.

11.1.2 All main cables (i.e. from apparatus case/relay room to apparatus case/points pothead) shall have their armouring earthed at both ends. (Refer to Appendix 5).

11.1.3 Tail cables (i.e. apparatus case/points pothead to final function, e.g. signal, points disconnection box, trackside disconnection box, etc.) shall not have their armouring earthed at either end. The armouring of all tail cables must be cut back and properly insulated, e.g. with shrink sleeving. (Refer to Appendix 5).

11.1.4 All gantries and metal structures spanning the track shall be bonded to the return rail. An earthing ring surrounding the base of the structure shall be provided and the gantry or metal

structure shall be bonded to the earthing ring.

**TYPICAL RELAY ROOM EARTH LAYOUT  
P.T.O.**

**APPENDIX 1**

**"PREVIEW COPY ONLY"**

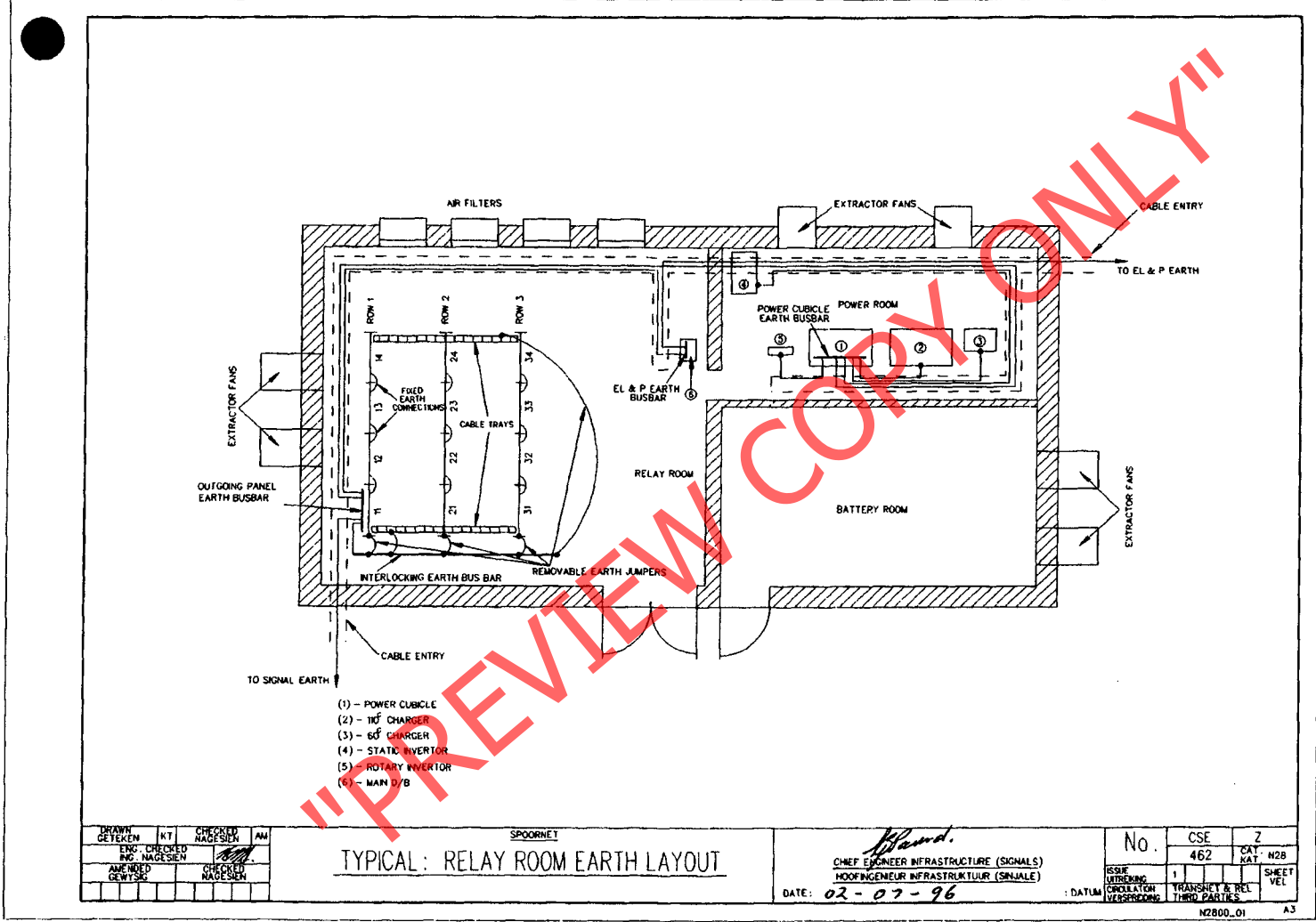

**EARTHING OF FRAMEWORK IN RELAY ROOMS      APPENDIX 2**

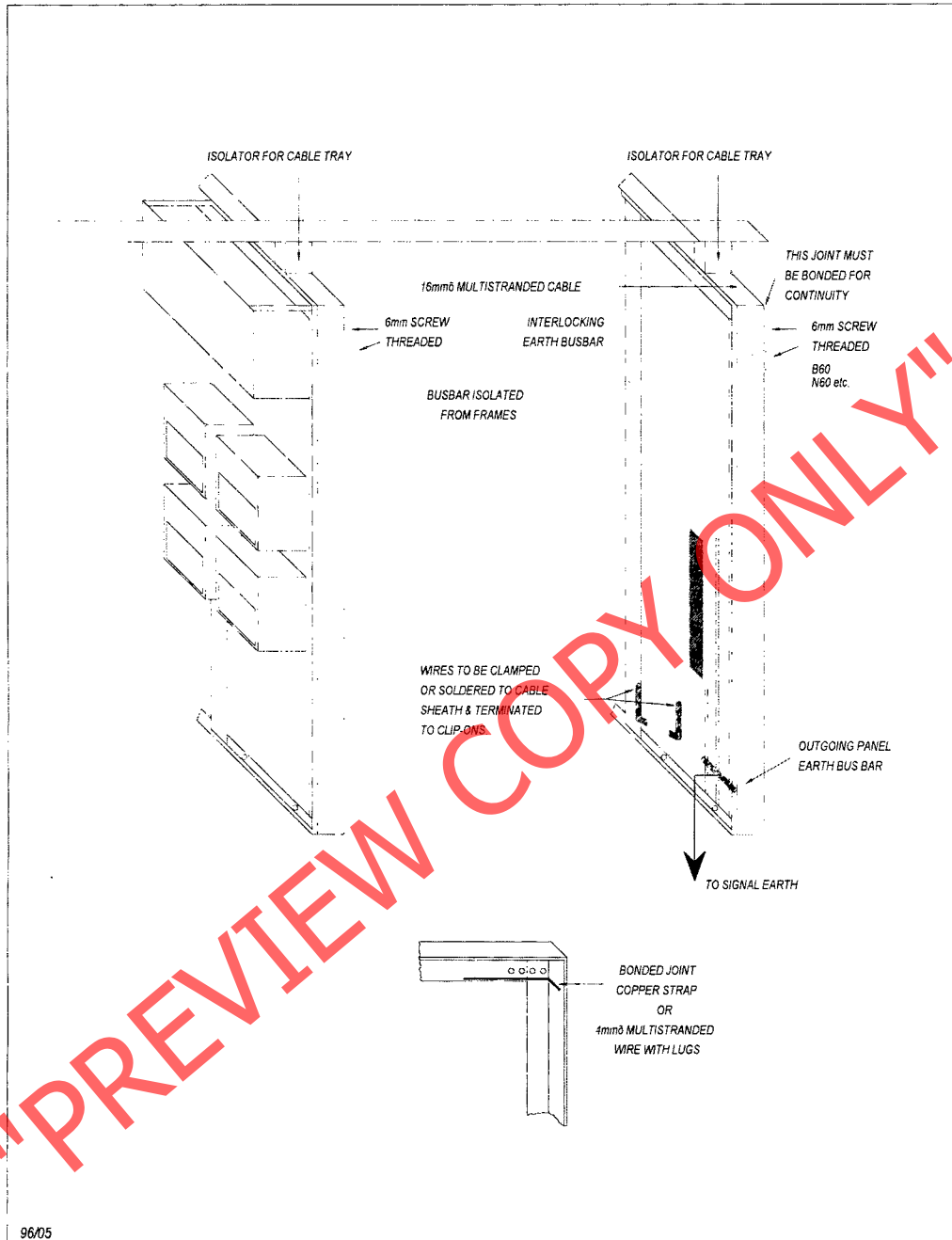

"PREVIEW COPY ONLY"

96/05

SPOORNET

**EARTHING OF FRAMEWORK IN RELAY ROOMS**  
**AARDING VAN RAAMWERK IN REL 1/16 KAMERS**

|                             |    |                     |    |   |            |                             |                                 |                |
|-----------------------------|----|---------------------|----|---|------------|-----------------------------|---------------------------------|----------------|
| DRAWN<br>GETEKEN            | SN | CHECKED<br>NAGESIEN | AM | SIGNED<br>GETEKEN   | G.B.PAVERD | <b>N</b>                    | CSE                             | 1155           |
| ENG CHECKED<br>ING NAGESIEN |    |                     |    | CHIEF ENGINEER INFRASTRUCTURE SIGNALS<br>HOOFINGENIEUR INFRASTRUKTUUR SINJALE |            |                             | 515                             | CAT<br>KAT N28 |
| AMENDED<br>GEWYSIG          |    | CHECKED<br>NAGESIEN |    | DATE  | 1996-07-01 | ISSUE<br>UITREIKING         | 1                               | SHEET<br>VEL   |
|                             |    |                     |    |   |            | CIRCULATION<br>VERSPREIDING | TRANSNET & REL<br>THIRD PARTIES | 1              |

115515W2801\_01

**EARTHING OF APPARATUS CASE  
P.T.O.**

**APPENDIX3**

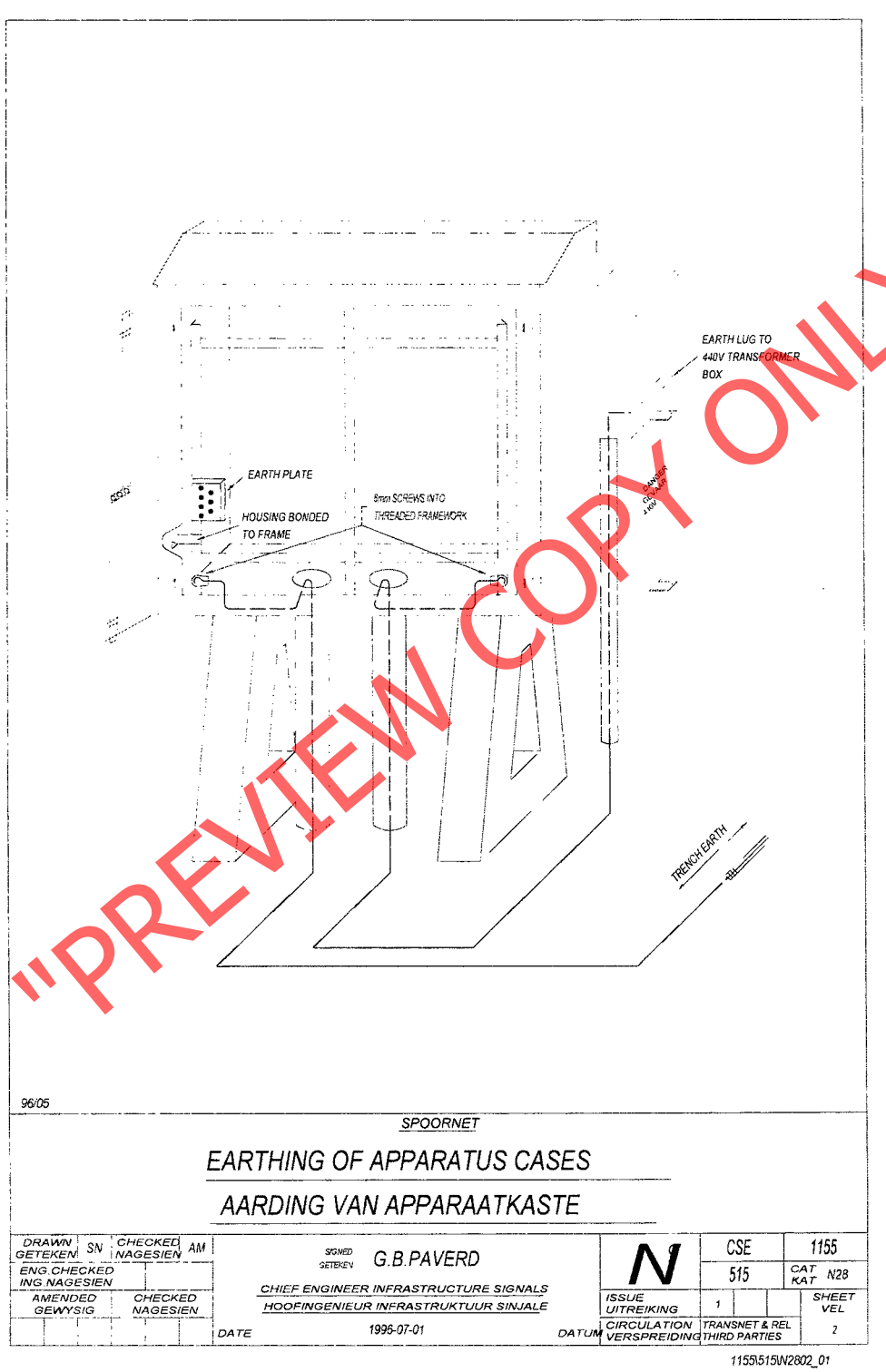

**INSTALLATION OF TRENCH EARTH  
P.T.O.**

**APPENDIX 4**

14/05

SPOORNET

**INSTALLATION OF TRENCH EARTH**

**INSTALLASIE VAN SLOOTAARDE**

|                               |    |                     |    |   |            |                             |                                 |                |
|-------------------------------|----|---------------------|----|---|------------|-----------------------------|---------------------------------|----------------|
| DRAWN<br>GETEKEN              | SN | CHECKED<br>NAGESIEN | AM | SIGNED<br>GETEKEN   | G.B.PAVERD | <b>N</b>                    | CSE                             | 1155           |
| ENG. CHECKED<br>ING. NAGESIEN |    |                     |    | CHIEF ENGINEER INFRASTRUCTURE SIGNALS<br>HOOFINGENIEUR INFRASTRUKTUUR SINJALE |            |                             | 515                             | CAT<br>KAT N28 |
| AMENDED<br>GEWYSIG            |    | CHECKED<br>NAGESIEN |    | DATE  | 1996-07-01 | CIRCULATION<br>UITREIKING   | 1                               | SHEET<br>VEL   |
|                               |    |                     |    |   |            | CIRCULATION<br>VERSPREIDING | TRANSNET & REL<br>THIRD PARTIES | 3              |

11551515W2803\_01

**MAIN CABLE EARTHING ARRANGEMENT  
PT.O.**

**APPENDIX 5**

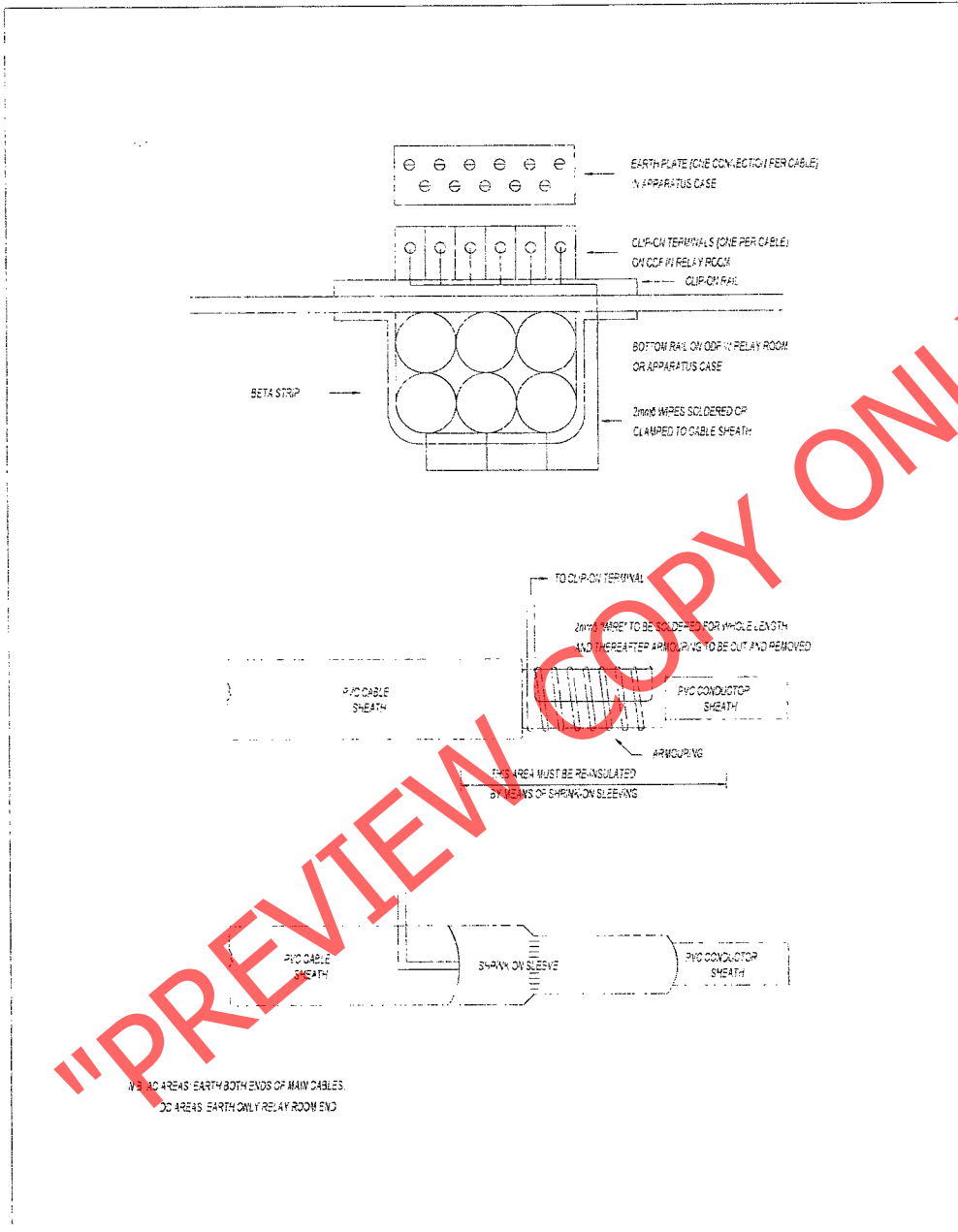

IN ALL AREAS EARTH BOTH ENDS OF MAIN CABLES.  
IN ALL AREAS EARTH ONLY RELAY ROOM END

96/05

SPOORNET

**MAIN CABLE EARTHING ARRANGEMENT  
HOOFKABELAARDRANGSKIKKING**

|                             |    |                     |    |   |            |                             |                                 |                |
|-----------------------------|----|---------------------|----|---|------------|-----------------------------|---------------------------------|----------------|
| DRAWN<br>GETEKEN            | SN | CHECKED<br>NAGESIEN | AM | SIGNED<br>GETEKEN   | G.B.PAVERD | <b>N</b>                    | CSE                             | 1155           |
| ENG CHECKED<br>ING NAGESIEN |    |                     |    | CHIEF ENGINEER INFRASTRUCTURE SIGNALS<br>HOOFINGENIEUR INFRASTRUKTUUR SINJALE |            |                             | 515                             | CAT<br>KAT N28 |
| AMENDED<br>GEWYSIG          |    | CHECKED<br>NAGESIEN |    | DATE  | 1996-07-01 | ISSUE<br>UITREIKING         | 1                               | SHEET<br>VEL   |
|                             |    |                     |    |   |            | CIRCULATION<br>VERSPREIDING | TRANSNET & REL<br>THIRD PARTIES | 4              |

11551515N2804\_01

This document is a whole is protected by copyright. The information contained herein is the sole property of Transnet Limited. It may not be used, disclosed or reproduced in part or in whole in any manner whatsoever, except with the written permission of and in a manner permitted by the proprietors.

# CSE 2A 615B

| CABLE KABEL | CORE KERN | 1   | FUNCTION FUNKSIE | CORE KERN | CABLE KABEL |
|-------------|-----------|-----|------------------|-----------|-------------|
| 4c<br>E1    | 1         | 1   | E1+              |           | 5           |
|             | 2         | 2   | E1A(1)           |           | 6           |
|             | 3         | 3   | E1A(2)           |           | 7           |
|             | 4         | 4   | E1-              |           | 8           |
| 4c<br>E2    | 1         | 5   | E2+              |           | 1           |
|             | 2         | 6   | E2A(1)           |           | 2           |
|             | 3         | 7   | E2A(2)           |           | 3           |
|             | 4         | 8   | E2-              |           | 4           |
| 6c<br>A615A | 1         | 9   | LOCKZR           |           |             |
|             | 2         | 10  | * NX             |           |             |
|             | 3         | 11  | EXR              |           |             |
|             | 4         | 12  | 2 CHR            | 1         | 4c          |
|             | 5         | 13  | * N              | 2         | CH2         |
|             | 6         | 14  |                  |           |             |
|             | 15        | B10 | 3                | 4c        |             |
|             | 16        | C10 | 4                | CH2       |             |
|             | 17        |     |                  |           |             |
|             | 18        |     |                  |           |             |
| 19          |           |     |                  |           |             |
| 20          |           |     |                  |           |             |

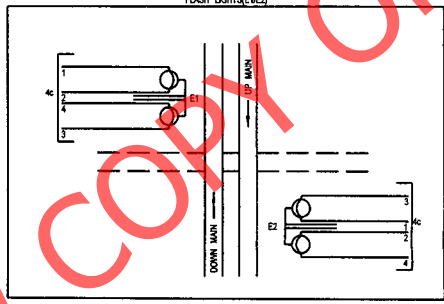
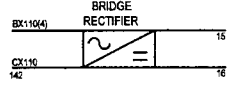
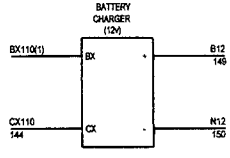
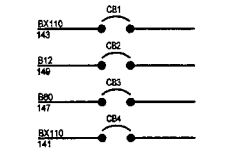
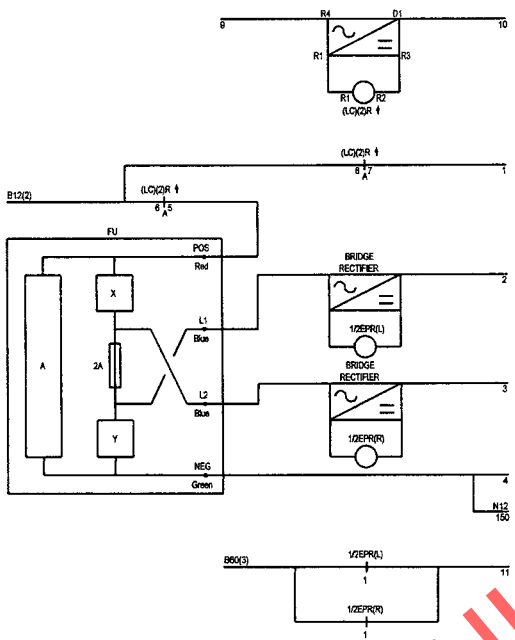

"PREVIEW COPY ONLY!"

|       |      |   |     |       |  |
|-------|------|---|-----|-------|--|
| 39    | 2°   | 1 | 141 | BX110 |  |
|       | 18mm | 2 | 142 | CX110 |  |
| A615A | 2°   | 1 | 143 | BX110 |  |
|       | 18mm | 2 | 144 | CX110 |  |
| A615C | 2°   | 1 | 145 | B80   |  |
|       | 18mm | 2 | 146 | N80   |  |
| A615D | 2°   | 1 | 147 | B80   |  |
|       | 18mm | 2 | 148 | N80   |  |
| A615E | 2°   | 1 | 149 | B12   |  |
|       | 18mm | 2 | 150 | N12   |  |

| POS | RELAY RELE   | F | B | TYPE          |
|-----|--------------|---|---|---------------|
| 1   | WBS QN1 8F8B | 1 | 2 | WBS QN1 8F.8B |
|     | (LC)Z R      | 3 | 4 |               |

| POS | RELAY RELE   | F | B | TYPE          |
|-----|--------------|---|---|---------------|
| 5   | MORGAN 2F.2B | 1 | 2 | MORGANS 2F.2B |
| 6   | 1/2EPR(L)    | 3 | 4 |               |
|     | 1/2EPR(R)    |   |   |               |

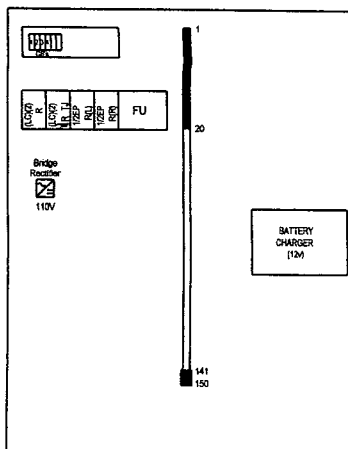

| DRAWN         | CHKD | CHECKED  | PK |
|---------------|------|----------|----|
| REYSEN        | B.G. | NAGESIEN |    |
| ENG CHECKED   |      |          |    |
| ING. NAGESIEN |      |          |    |
| AMENHOED      |      | CHECKED  |    |
| SEWYSIG       |      | NAGESIEN |    |

SPOORNET  
**A615B**  
(RIVERTON)

*Don*  
CHIEF ENGINEER INFRASTRUCTURE (SIGNALS)  
HOOFDINGENIEUR INFRASTRUKTUUR (SINIALE)  
DATE 2007/8/23 DATUM

| No           | CSE  | 2A |
|--------------|------|----|
|              | 615B |    |
| ISSUE        | 8    |    |
| UTREININGS   |      |    |
| CIRCULATION  |      |    |
| VERSPREIDING |      |    |

SHEET 1 of 1  
VEL 1 of 1



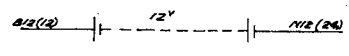
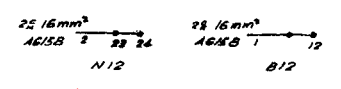
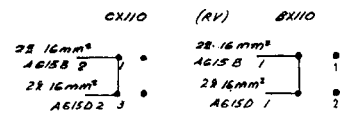

"PREVIEW COPY ONLY"

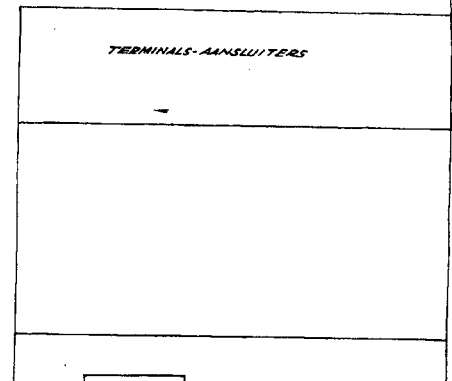

|                     |                     |                     |
|---------------------|---------------------|---------------------|
| 9-2-71              | DRAWN<br>GETEKEN    | CHECKED<br>NAGESEEN |
| AMENDED<br>GEMUTSIG | CHECKED<br>NAGESEEN |                     |
| GL                  | AS                  | CB                  |

S.A.R. - S.A.S  
**A615C**  
(RIVERTON)

SIGNALS  
SINIALE  
KOMMUNIKASIE

CHIEF ENGINEER  
HOOFD-SINIAALINGENIEUR  
DATE 2007/8/23  
DATUM

|                         |      |              |
|-------------------------|------|--------------|
| No                      | CSE  | 2A           |
|                         | 615C |              |
| ANSOORDING<br>TYSWYDING | X    | 3            |
|                         |      | SHEET<br>VEL |

"PREVIEW COPY ONLY"

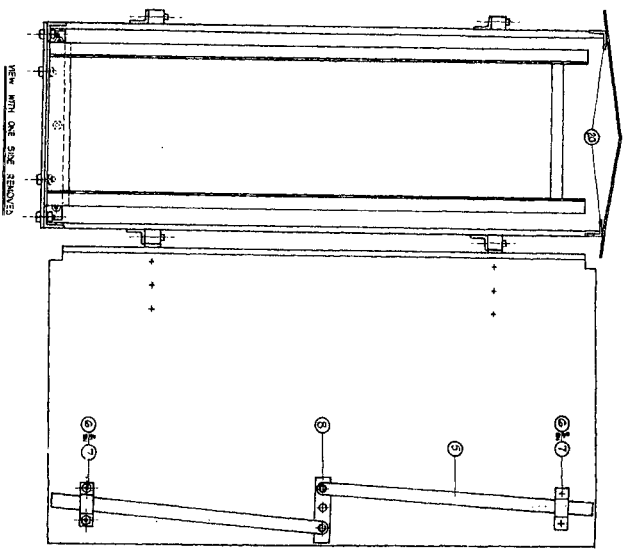
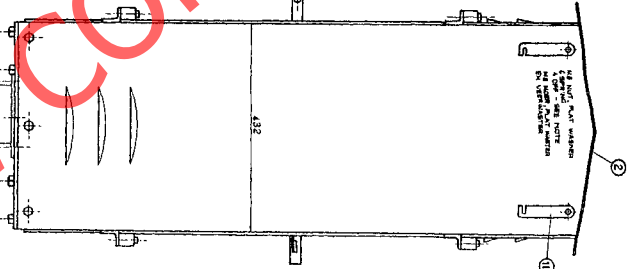
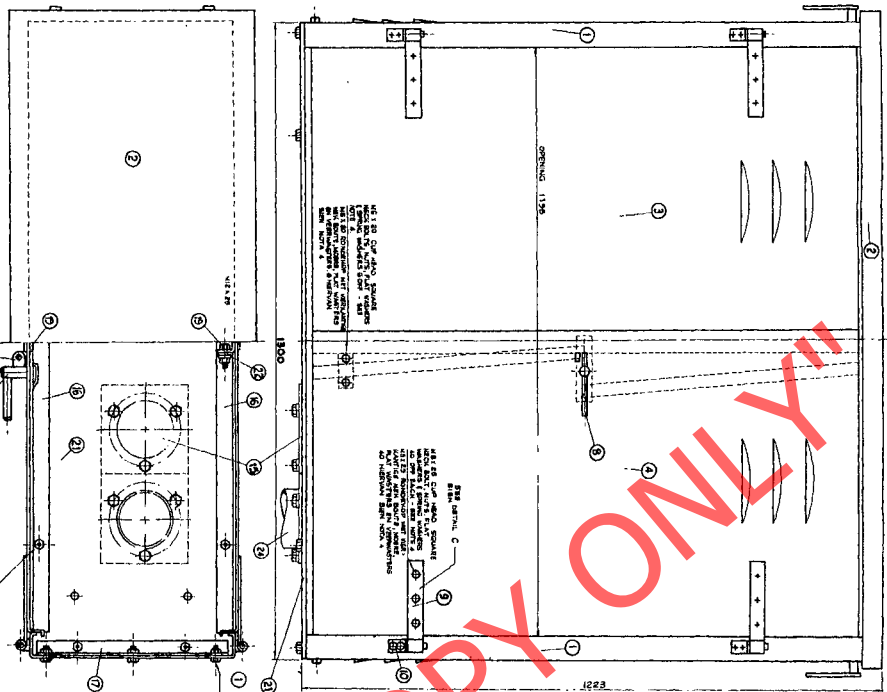

- NOTE**
1. All dimensions are in millimeters.
  2. To be finished in accordance with instructions.
  3. Material & finish as specified.
  4. All work shall conform to the latest standards.
  5. The manufacturer shall be responsible for the correct assembly and operation of the apparatus.

- NOTE**
1. Material & finish as specified.
  2. To be finished in accordance with instructions.
  3. Construction as shown on drawings.
  4. All work shall conform to the latest standards.
  5. The manufacturer shall be responsible for the correct assembly and operation of the apparatus.

|                          |  |  |  |                          |  |  |  |
|--------------------------|--|--|--|--------------------------|--|--|--|
| APPARATUS CASE           |  |  |  | APPARATUS CASE           |  |  |  |
| TYPE 5                   |  |  |  | TYPE 5                   |  |  |  |
| ASSEMBLY                 |  |  |  | ASSEMBLY                 |  |  |  |
| SCALE: 1:3               |  |  |  | SCALE: 1:3               |  |  |  |
| DATE: 1957               |  |  |  | DATE: 1957               |  |  |  |
| DRAWN BY: [Signature]    |  |  |  | DRAWN BY: [Signature]    |  |  |  |
| CHECKED BY: [Signature]  |  |  |  | CHECKED BY: [Signature]  |  |  |  |
| APPROVED BY: [Signature] |  |  |  | APPROVED BY: [Signature] |  |  |  |
| NO. 1                    |  |  |  | NO. 1                    |  |  |  |
| REV. 1                   |  |  |  | REV. 1                   |  |  |  |
| ST. 547                  |  |  |  | ST. 547                  |  |  |  |
| U                        |  |  |  | U                        |  |  |  |

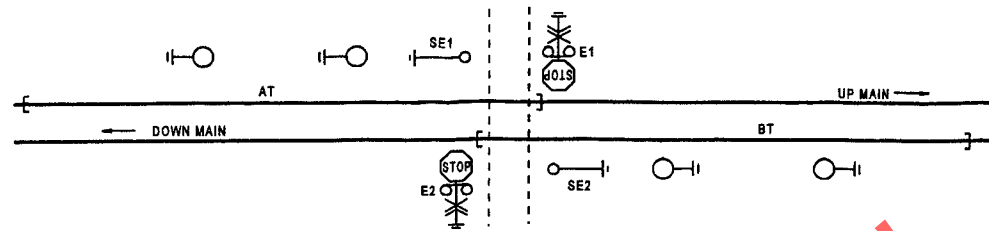

NOTE: TRACK CIRCUITS MUST PROVIDE 30 SECONDS WARNING

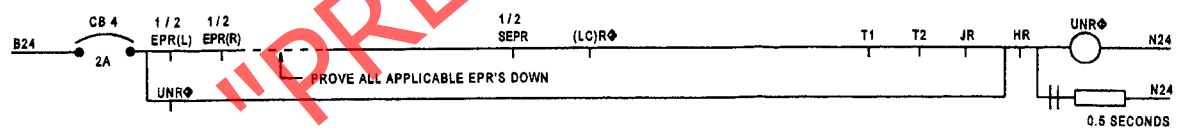
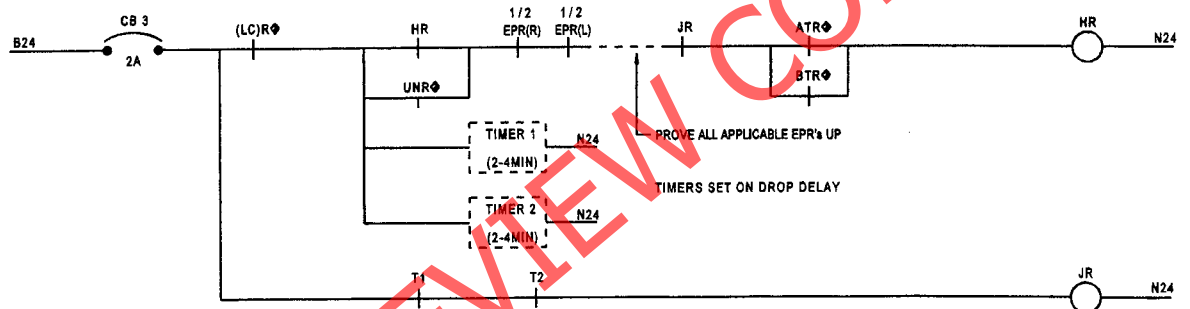
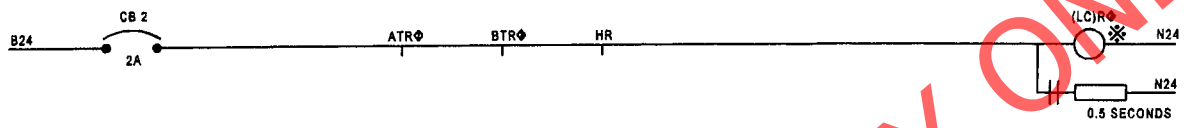

REFER TO: FLASH LIGHT WIRING BBB3209  
POWER SUPPLY BBB3208  
MASTER RECORD INDEX BBB3202

✱ PRIMARY RELAY

© COPYRIGHT PROTECTED

|                               |                           |   |   |   |  |
|-------------------------------|---------------------------|---|---|---|--|
| RESERVED FOR CONTRACTOR'S USE | CP REF :<br>VERSION INFO: | CDO REF : CDO/4307<br>DRAWN : A. STEYN<br>DESIGNED:<br>CHECKED : P. KAMFFER | DATE:<br>-----<br>APPROVED<br>-----<br>AUTHORISED | CENTRAL DRAWING OFFICE (INFRASTRUCTURE)<br><br><b>LEVEL CROSSING - FLASH LIGHTS<br/>DOUBLE LINE (UNI-DIRECTIONAL)</b><br>42 | <br><b>BBC0003</b><br>VERSION 1 |
|-------------------------------|---------------------------|---|---|---|--|

RESERVED FOR  
CONTACTORS USE

CP REF : 888999  
VERSION INFO:  
UP/DN KR  
NOTE ADDED

CDO REF : CDO/4307  
DRAWN : T.D. RAJULINI  
DESIGNED :  
CHECKED : P. KAMFNER

© COPYRIGHT PROTECTED

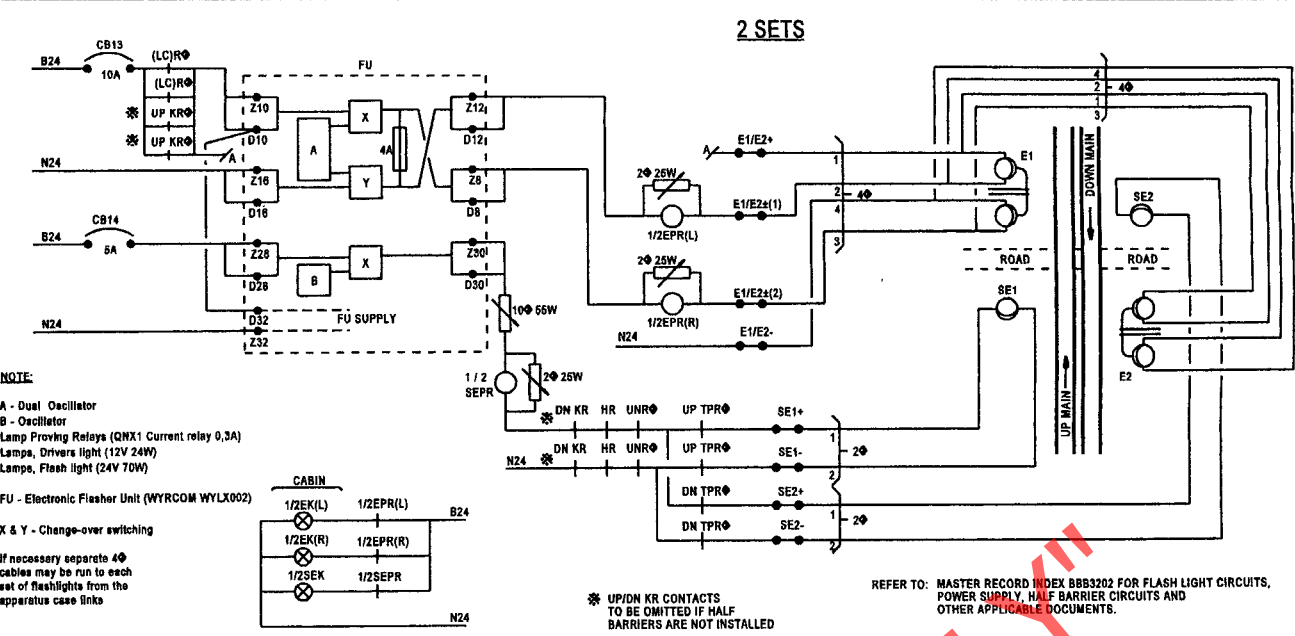

**NOTE:**

- A - Dual Oscillator
- B - Oscillator
- Lamp Proving Relays (QNX1 Current relay 0.3A)
- Lamps, Drivers light (12V 24W)
- Lamps, Flash light (24V 70W)

FU - Electronic Flasher Unit (WYRCOM WYLX002)

X & Y - Change-over switching

If necessary separate 4Φ cables may be run to each set of flashlights from the apparatus case links

\* UP/DN KR CONTACTS TO BE OMITTED IF HALF BARRIERS ARE NOT INSTALLED

REFER TO: MASTER RECORD INDEX 8883202 FOR FLASH LIGHT CIRCUITS, POWER SUPPLY, HALF BARRIER CIRCUITS AND OTHER APPLICABLE DOCUMENTS.

DATE: \_\_\_\_\_  
APPROVED: \_\_\_\_\_  
AUTHORISED: \_\_\_\_\_

LEVEL CROSSING - SOLID STATE FLASH LIGHT WIRING  
DOUBLE LINES (UNI-DIRECTIONAL)

CENTRAL DRAWING OFFICE (INFRASTRUCTURE)

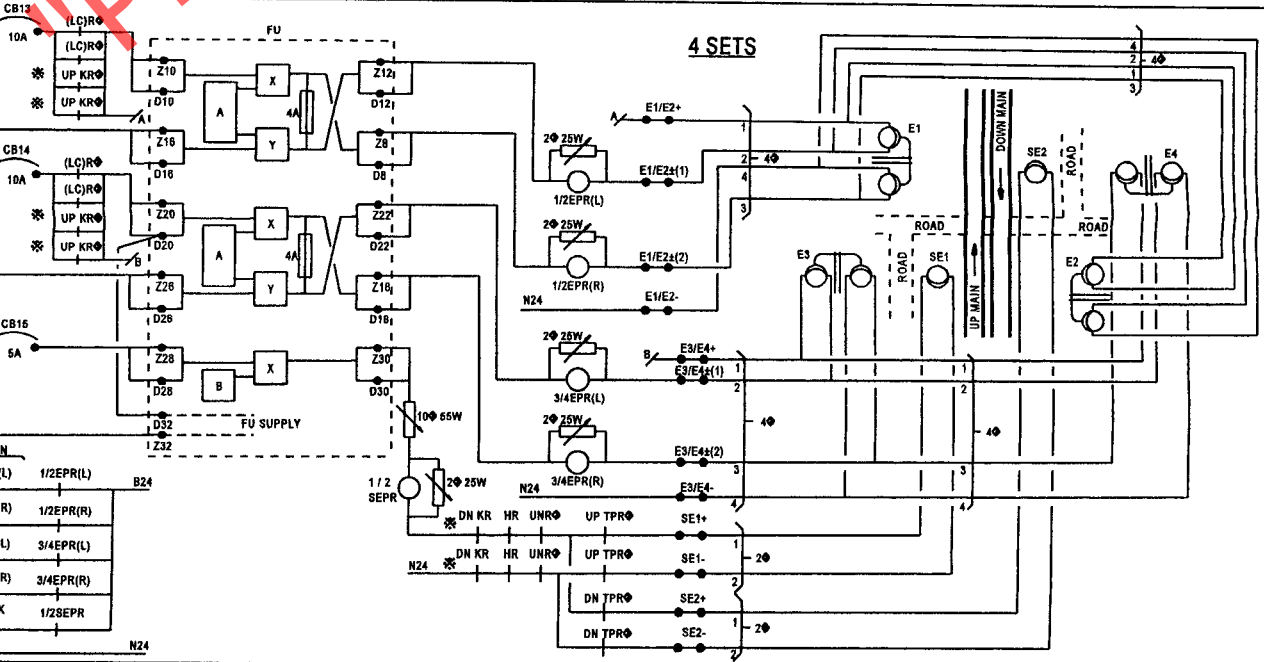
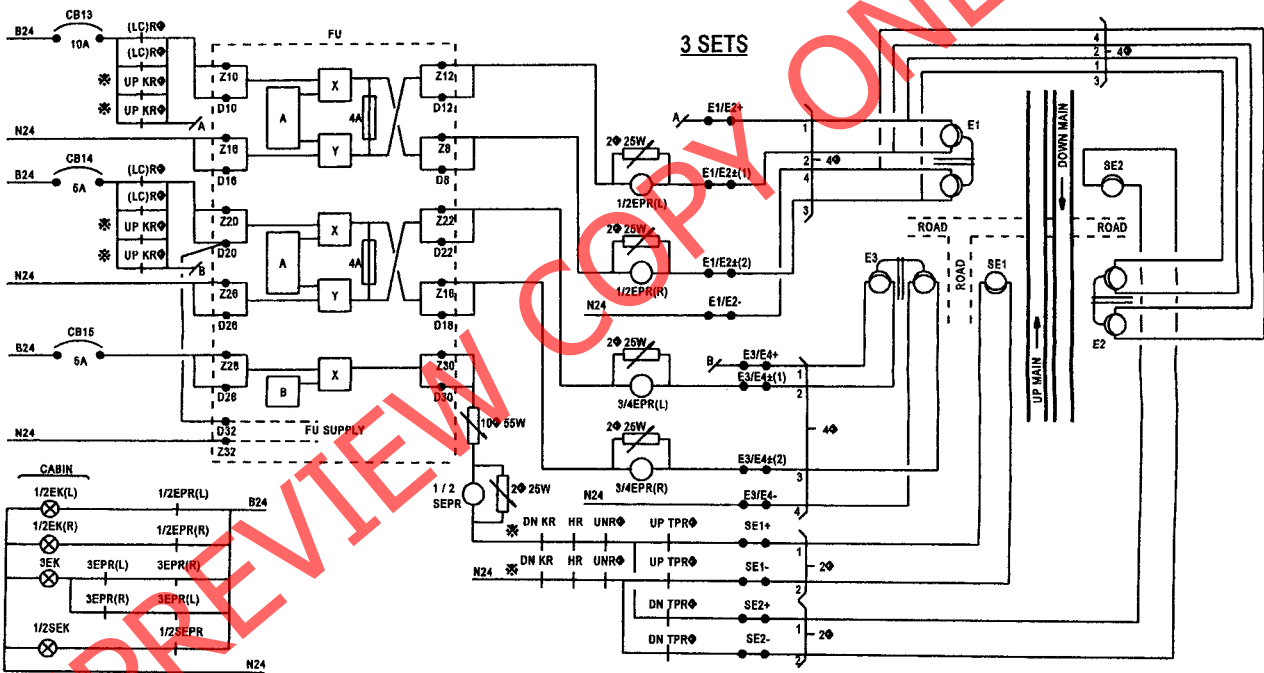

**SPOORNET**  
BB83209  
VERSION 3

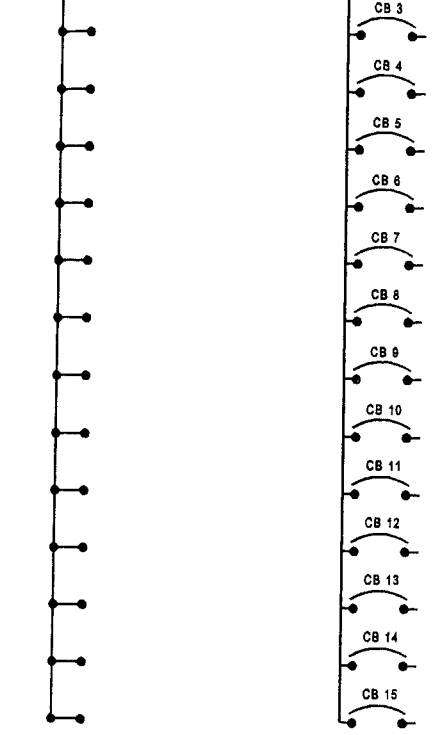
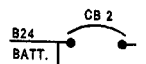
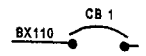
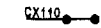
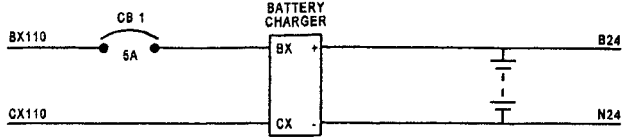

"PREVIEW COPY ONLY"

© COPYRIGHT PROTECTED

|                                  |                                    |   |   |  |   |
|----------------------------------|------------------------------------|---|---|--|---|
| RESERVED FOR<br>CONTRACTOR'S USE | CP REF : 2003/006<br>VERSION INFO: | CDO REF : CDO/2331<br>DRAWN : A. STEYN<br>DESIGNED:<br>CHECKED : P. KAMFFER | DATE:<br>-----<br>APPROVED<br>-----<br>AUTHORISED | CENTRAL DRAWING OFFICE (INFRASTRUCTURE)<br><br>LEVEL CROSSING - FLASH LIGHTS / HALF BARRIERS<br>POWER SUPPLY | <b>SPOORNET</b><br>BBB3206<br>VERSION 2 |
|----------------------------------|------------------------------------|---|---|--|---|

144

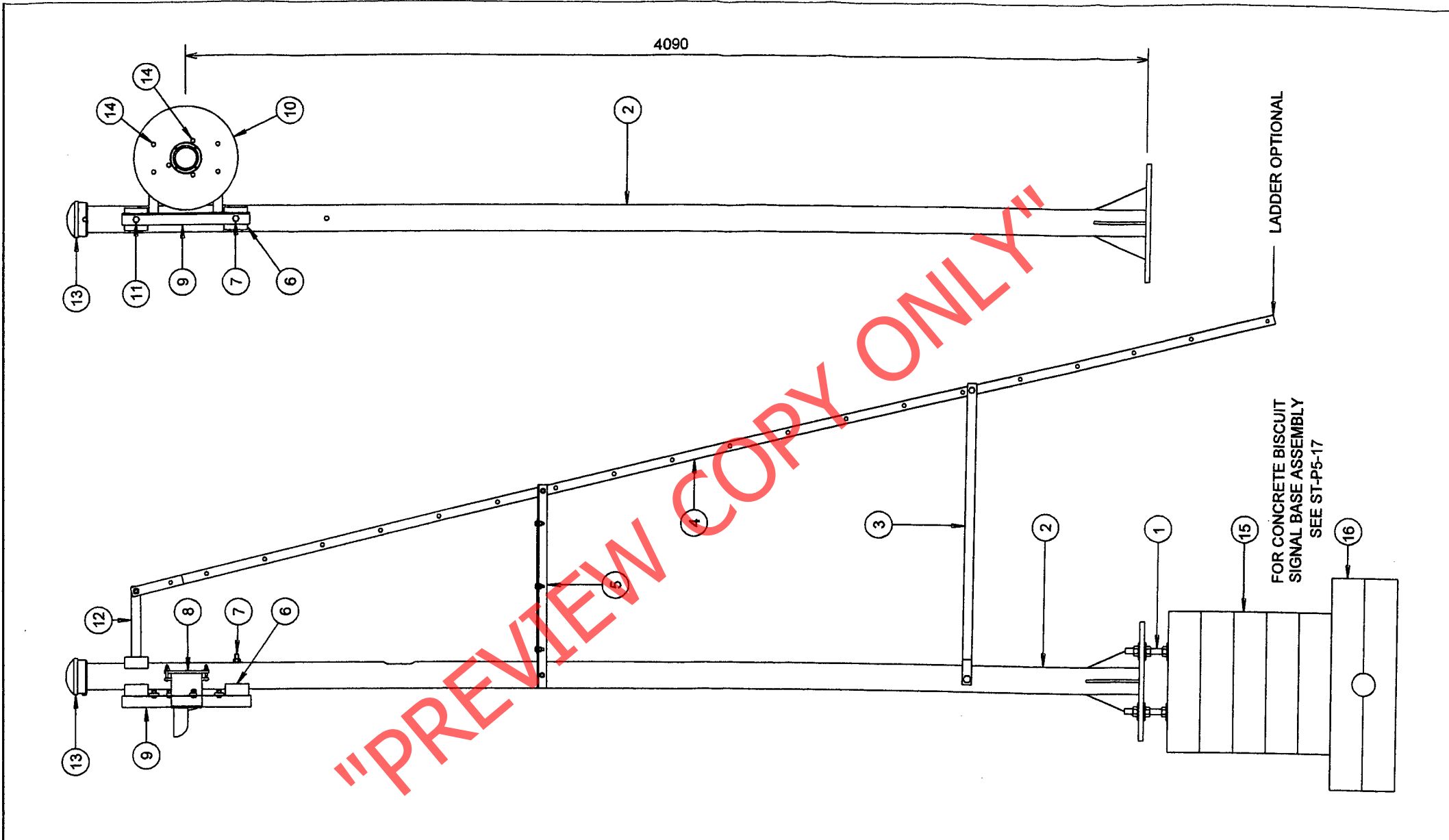

"PREVIEW COPY ONLY"

NOTE: FOR MATERIAL LIST SEE: BBB3552.VER1

© COPYRIGHT PROTECTED. PREPARED BY CENTRAL DRAWING OFFICE

DIMENSIONS : mm  
 TOLERANCE :  
 MATERIAL :  
 VERSION INFO :

SCALE : 1 : 16  
 ITEM NO :

DO REF : CDO/2313  
 CP REF :  
 DRAWN : NE  
 DESIGNED : NE  
 CHECKED : PK

DATE:  
 ----- APPROVED -----  
 ----- AUTHORISED -----

SIGNAL ASSEMBLY FOR DRIVERS LIGHT  
 AT LEVEL CROSSINGS

45

**SPOORNET**

BBB3549  
 VERSION 1

A3

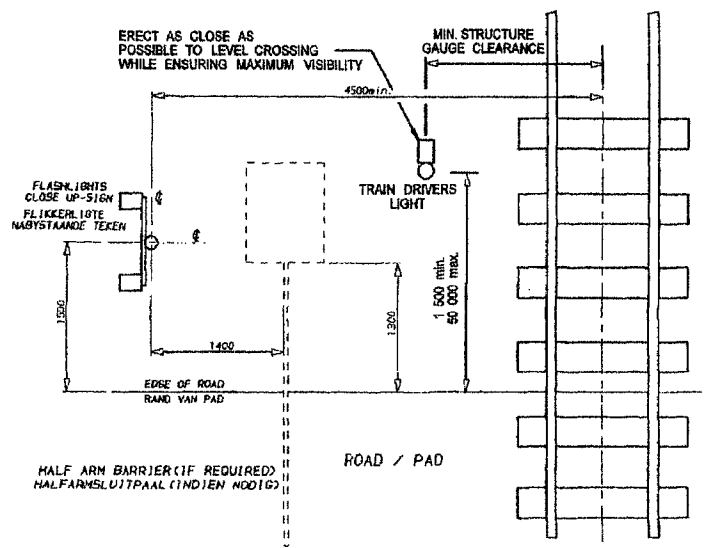

PLAN VIEW SHOWING POSITION OF FLASHLIGHTS CLOSE-UP SIGN AND IF REQUIRED HALF ARM BARRIER.  
 PLANAANSIG TOON POSISIE VAN FLIKKERLIGTE NABYSTAANDE TEKEN EN INDIEN NODIG HALFARMSLUITPAAL

METHOD OF MOUNTING POST TO BE DETERMINED ON SITE.  
 METODE VAN PAALMONTERING MOET TER PLAATSE VASGESTEL WORD.

TYPES OF MOUNTING AVAILABLE: IF GROUND CONDITION PERMITS THE POST MUST BE BURIED TO 1,220.  
 IF GROUND IS ROCKY, "BISCUITS" OR A CONCRETE BASE MAY BE USED.

TIPES VAN MONTERING BESKIKBAAR, WANNEER GROND TOESTAND DIT TOELAAT MOET DIE PAAL TOT 1,220 DIEP BEGRAWE WORD.  
 WANNEER GROND ROTSAGTIG IS, MAG "BISCUITS" OF 'n BETON BASIS GEBRUIK WORD.

NOTES/NOTAS

- 1) 750-1500 IN SUBURBAN AREAS  
 IN VOORSTEDELIKE GEBIEDE
- 2000-2400 IN COUNTRY AREAS  
 IN BUITESTEDELIKE GEBIEDE

- 2) CROSS ALONE FOR SINGLE TRACK.  
 1 ADDITIONAL CHEVRON FOR MULTIPLE TRACKS  
 KRUIS ALLEEN VIR ENKELSPOOR.  
 1 ADDISIONELE CHEVRON VIR MEERVOUDIGE SPORE.

- 3) a) LIGHTS AND ARM SUPPLIED BY CONTRACTOR COMPLETE WITH FITTINGS.  
 LIGTE EN ARMS WORD VOLLEDIG MET TOEBEHORE DEUR KONTRAKTEUR VOORSIEN.
- b) CROSS & STOP SIGN COMPLETE WITH FITTINGS SUPPLIED BY CE OPS. MAINTENANCE INFRA (CIVILS).  
 KRUIS EN STOPTEKEN WORD VOLLEDIG MET TOEBEHORE DEUR HI OPS. INSTANDHOUDING INFRA (SIVIEL) VOORSIEN.
- c) FLASHLIGHTS MAINTAINED BY CE OPS. MAINTENANCE INFRA (SIGNALS).  
 FLIKKERLIGTE WORD ONDERHOU DEUR HI OPS. INSTANDHOUDING INFRA (SINJALE).

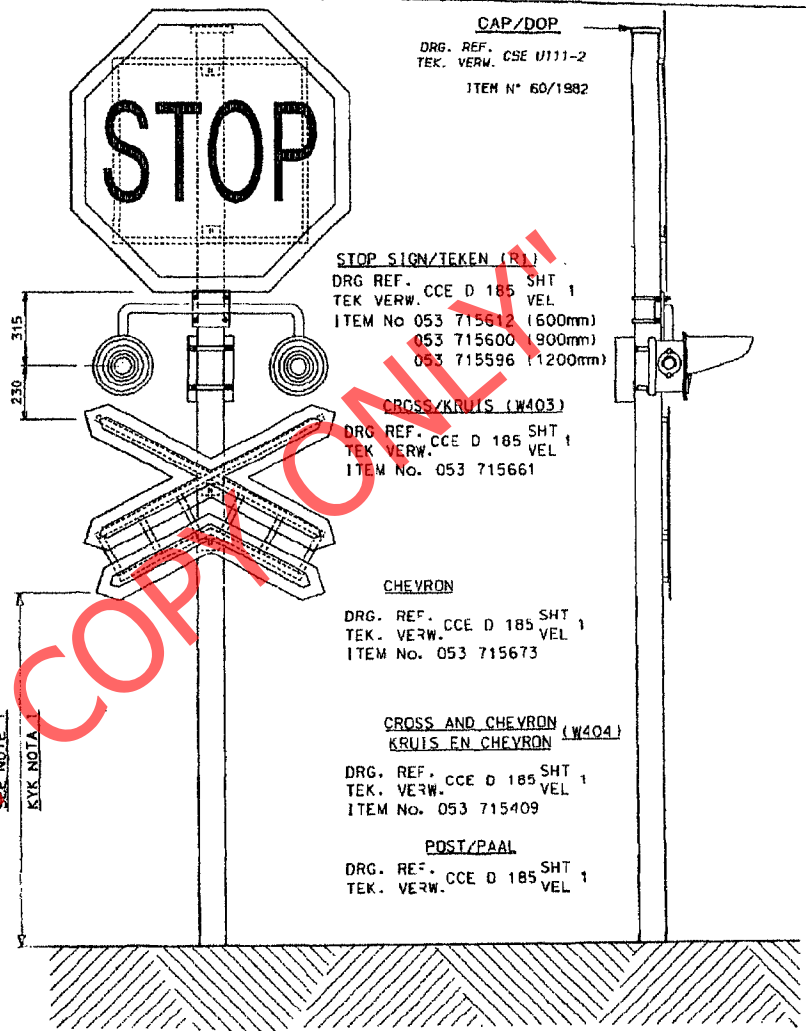

CAP/DOP  
 DRG. REF. CCE D 185 SHT 1  
 TEK. VERW. CSE U111-2  
 ITEM N° 60/1982

STOP SIGN/TEKEN (R1)  
 DRG REF. CCE D 185 SHT 1  
 TEK VERW. CSE U111-2  
 ITEM No 053 715612 (600mm)  
 053 715600 (900mm)  
 053 715596 (1200mm)

CROSS/KRUIS (W403)  
 DRG REF. CCE D 185 SHT 1  
 TEK VERW. CCE D 185 SHT 1  
 ITEM No. 053 715661

CHEVRON  
 DRG. REF. CCE D 185 SHT 1  
 TEK. VERW. CCE D 185 SHT 1  
 ITEM No. 053 715673

CROSS AND CHEVRON (W404)  
 KRUIS EN CHEVRON  
 DRG. REF. CCE D 185 SHT 1  
 TEK. VERW. CCE D 185 SHT 1  
 ITEM No. 053 715409

POST/PAAL  
 DRG. REF. CCE D 185 SHT 1  
 TEK. VERW. CCE D 185 SHT 1

"PREVIEW COPY"

SEE NOTE 1  
 KYK NOTA 1

REFER TO : SIGNING FOR RAILWAY CROSSINGS SARTSM VOL 2 CHAPTER 7

|                                       |                              |                           |                              |                               |    |
|---------------------------------------|------------------------------|---------------------------|------------------------------|-------------------------------|----|
| 12/2002                               | SEE ECP 2002080              | SR                        | PK                           | 3                             |    |
| 09/02                                 | SEE ECP 2002037              | A                         | PK                           | 2                             |    |
| 06/91                                 | SEE E.C.P. ST-Q1-1-101       | CRS                       | 8                            | 1                             |    |
| DATE<br>DATUM                         | AMENDMENT - WYSIBING         | AMENDED<br>GEWYSIG        | ED. CHECK<br>TREG. WESIEDLIG | ENG. CHECK<br>TREG. WESIEDLIG | N° |
| S.A.S. - S.A.S.                       |                              |                           |                              |                               |    |
| <b>FLASHLIGHTS/FLIKKERLIGTE</b>       |                              |                           |                              |                               |    |
| MOUNTING OF LIGHTS AND CHEVRON/CROSS. |                              |                           |                              |                               |    |
| MONTERING VAN LIGTE EN CHEVRON/KRUIS. |                              |                           |                              |                               |    |
| DATE 07/02/10                         | ENG. CHECKED<br>IR. NAGESIEN | MATERIAL                  | ST                           |                               |    |
| STORES CODE<br>WAGSTROKODE            | ITEM                         | CHIEF ENGINEER<br>(S & T) | No                           | Q1-1-1                        |    |
| TRAIN<br>GETREK                       | CHECKED<br>NAGESIEN          | DATE 17-6-87              | AMENDMENT<br>WYSIGING        | 1/3                           |    |

Riverton Replace 12v flash light system with 24v flash light system

**Scope of work**

Replace flash lights that is a 12v system with a 24v flash light system  
Plans for the flash lights to be included.

**Specifications**

Flash lights to be done according to BBB3202 ver 3 for level crossings.

1. Flash light circuits for double lines (Uni-directional) BBC0003
2. Solid state flash light wiring for double lines (Uni-directional) BBB3209
3. Power supply BBB3206
4. Mounting of flash lights CSE(ST)-1-1

**Apparatus cases.**

Apparatus cases involved to be replace by Apparatus case Type 5 CSE(ST) U 947

**Trenching**

Trenching must be done according to specification no. CSE-1155-516/1

**Earthing**

Earthing to be done according to Specification no. CSE-1155-515

Existing App cases A615B and A615C is included.

Interlocking is done in the relay room were the working of the flash lights are initiated with a (LC)R that falls away and dropping the (LC)(2)R relay in app. Case A615B

"PREVIEW COPY ONLY"



CABLE PLAN CSE 2T 27  
 C.T.C. CROSSING PLACE  
 SPOORPLAN MK.1 INTERLOCKING  
 CS90 REMOTE CONTROL FROM KIMBERLEY  
 6,6KV POWER LINE  
 3KV D.C. TRACTION

C04-L202-SRV

C04-L202-ERV2MFL

RV TRACTION POWER KEY

C04-L202-EWS2RV

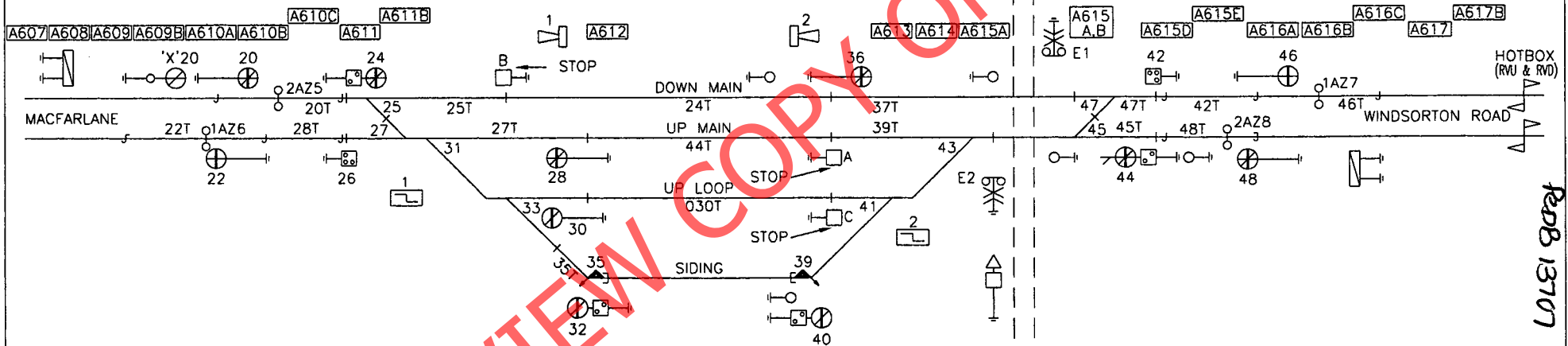

RevB 13707  
48

RevB 13707

| SIGNAL | Km POINT | SIGNAL | Km POINT | SIGNAL | Km POINT | SIGNAL | Km POINT | POINTS | Km POINT | POINTS | Km POINT | POINTS | Km POINT | MISC  | Km POINT | TR. CCT | FREQ. | TR. CCT | FREQ. | MISC. | Km POINT |
|--------|----------|--------|----------|--------|----------|--------|----------|--------|----------|--------|----------|--------|----------|-------|----------|---------|-------|---------|-------|-------|----------|
| 48     | 278,457  | 30     | 280,077  | 24     | 280,325  |        |          | 25     | 280,255  | 41     |          |        |          | E1/E2 | 279,268  | 20      | A     | 48      | C     | RR    | 279,833  |
| 46     | 278,523  | 28     | 280,077  | 22     | 280,972  |        |          | 29     | 280,203  | 37     |          |        |          | H/BOX | 275,304  | 22      | C     |         |       |       |          |
| 42     | 279,170  | 32     |          | 20     | 281,063  |        |          | 31     |          | 43     |          |        |          |       |          | 28      | D     |         |       |       |          |
| 44     | 279,170  | 40     |          | 'X'20  | 281,408  |        |          | 33     |          | 45     |          |        |          |       |          | 42      | A     |         |       |       |          |
| 36     | 279,540  | 26     | 280,264  |        |          |        |          | 35     |          | 47     |          |        |          |       |          | 46      | B     |         |       |       |          |

|                     |     |                             |                        |               |          |  |  |  |  |  |  |  |                    |  |      |  |            |  |
|---------------------|-----|-----------------------------|------------------------|---------------|----------|--|--|--|--|--|--|--|--------------------|--|------|--|------------|--|
| DRAWN<br>GETEKEN    | 87U | ISSUED WITH - UITGEREIK MET |                        |               | SPOORNET |  |  |  |  |  |  |  | REGION<br>STREEK   |  | S/KY |  | 2N         |  |
|                     |     | NOTICE<br>KENNISGEWING      | REFERENCE<br>VERWYSING | DATE<br>DATUM |          |  |  |  |  |  |  |  |                    |  |      |  |            |  |
| CHECKED<br>NAGESIEN | 87U |                             |                        |               | RIVERTON |  |  |  |  |  |  |  | SIGNALS<br>SINJALE |  | No   |  | SHT<br>VEL |  |
|                     |     |                             |                        |               |          |  |  |  |  |  |  |  |                    |  |      |  |            |  |