

Transnet freight rail, a division of

TRANSNET SOC LTD

Registration Number 1990/000900/30

[hereinafter referred to as **Transnet**]

REQUEST FOR QUOTATION [RFQ] No BFX/52917

FOR THE SUPPLY/PROVISION OF: AS AND WHEN CONTROL OF VEGETATION INCLUDING TREES , BUSH AND CUTTING OF GRASS IN THE BLOEMFONTEIN AREA FOR A PERIOD OF 24 MONTHS OR R1.9M WICHEVER OCCURS FIRST

FOR DELIVERY TO: REAL ESTATE MANSGEMENT BLOEMFONTEIN

ISSUE DATE: 23 April 2014

CLOSING DATE: 27 May 2014

CLOSING TIME: 10:00

COMPULSA SITE MEETING

DATE: 13 MAY 2014

VENUE: REAL ESTATE MANAGEMENT , NATHAN STREET , BLOEMFONTEIN

TIME : 11H00

ANNEXURE (A) B-BBEE PREFERENCE POINTS CLAIM FORM

Section 1
NOTICE TO BIDDERS

Quotations which must be completed as indicated in Section 2 of this RFQ are to be submitted as follows:

METHOD: COURRIER OR BY HAND
CLOSING VENUE: THE SECRETARIAT
 ACQUISITION COUNCIL
 ADMIN SUPPORT OFFICE
 TENDER BOX
 OFFICE NO 2
 REAL ESTATE MANAGEMENT BUILDING
 AUSTIN STREET
 BEACONSFIELD
 KIMBERLEY
 CONTACT PERSON MAGGIE PAIN TEL NO 053 – 838 3341

1 ON OR AFTER 05 MAY 2014 RFQ DOCUMENTS MAY BE INSPECTED AT, AND ARE OBTAINABLE FROM THE REGIONAL SUPPLY CHAIN OFFICE, 1ST FLOOR, ROOM 101, TRANSNET ENGINEERING BUILDING, TRANSNET ROAD BLOEMFONTEIN. ARRANGEMENTS FOR THE COLLECTION OF THE RFQ DOCUMENTS CAN BE MADE WITH MR. JAKKIE KOTZE ON TELEPHONE NUMBER 051-408 2328 OR EMAIL JAKKIE.KOTZE@TRANSNET.NET

2 NO RFQ WILL BE ISSUED AFTER 12 MAY 2014 AT 15H00

3 Responses to RFQ

Responses to this RFQ [**Quotations**] must not include documents or reference relating to any other quotation or proposal. Any additional conditions must be embodied in an accompanying letter.

4 Broad-Based Black Economic Empowerment [B-BBEE]

Transnet fully endorses and supports the Government's Broad-Based Black Economic Empowerment Programme and it would therefore prefer to do business with local business enterprises who share these same values. Transnet will accordingly allow a "preference" to companies who provide a valid B-BBEE Verification Certificate. All procurement transactions will be evaluated accordingly.

4.1 B-BBEE Scorecard and Rating

As prescribed in terms of the Preferential Procurement Policy Framework Act (PPPFA), Act 5 of 2000 and its Regulations, Respondents are to note that the following preference point systems are applicable to all bids:

- the 80/20 system for requirements with a Rand value of up to R1 000 000 (all applicable taxes included); and
- the 90/10 system for requirements with a Rand value above R1 000 000 (all applicable taxes included).
- Bidders are to note that if the 80/20 preference point system is stipulated in this RFP and all Bids received exceed R1 000 000.00, the RFP must be cancelled. Similarly, if the 90/10 preference point system is stipulated in this RFP and all Bids received are equal to or below R1 000 000.00, the RFP must be cancelled.

The value of this bid is estimated to exceed R1 000 000 (all applicable taxes included); and therefore the **90/10** system shall be applicable.

When Transnet invites prospective suppliers to submit Proposals for its various expenditure programmes, it requires Respondents to have their B-BBEE status verified in compliance with the Codes of Good Practice issued in terms of the Broad Based Black Economic Empowerment Act No. 53 of 2003.

The Department of Trade and Industry recently revised the Codes of Good Practice on 11 October 2013 [Government Gazette No. 36928]. The Revised Codes will replace the Black Economic Empowerment Codes of Good Practice issued on 9 February 2007. The Revised Codes provide for a one year transitional period starting 11 October 2013. During the transitional period, companies may elect to be measured in terms of the Revised Codes or the 2007 version of the Codes. After the first year of the implementation of the Revised Codes, B-BBEE compliance will be measured in terms of the Revised Codes without any discretion. Companies which are governed by Sector-specific Codes will be measured in terms of those Sector Codes.

As such, Transnet will accept B-BBEE certificates issued based on the Revised Codes. Transnet will also continue to accept B-BBEE certificates issued in terms of the 2007 version of the Codes provided it was issued before 10 October 2014. Thereafter, Transnet will only accept B-BBEE certificates issued based on the Revised Codes.

Respondents are required to complete Annexure A [the B-BBEE Preference Point Claim Form] and submit it together with proof of their B-BBEE Status as stipulated in the Claim Form in order to obtain preference points for their B-BBEE status.

Note: Failure to submit a valid and original B-BBEE certificate or a certified copy thereof at the Closing Date of this RFQ will result in a score of zero being allocated for B-BBEE.

[Refer clause 21 below for Returnable Documents required]

5 Communication

Respondents are warned that a response will be liable for disqualification should any attempt be made by a Respondent either directly or indirectly to canvass any officer(s) or employee of Transnet in respect of this RFQ between the closing date and the date of the award of the business.

A Respondent may, however, before the closing date and time, direct any written enquiries relating to the RFQ to the following Transnet employee:

Name: Jakkie Kotze Email: Jakkie.kotze@transnet.net

Respondents may also, at any time after the closing date of the RFQ, communicate with the Secretariat of the Transnet Acquisition Council on any matter relating to its RFQ response:

Telephone 053 8383341 Email: Maggie.pain@transnet.net

6 Tax Clearance

The Respondent's original and valid Tax Clearance Certificate must accompany the Quotation. Note that no business shall be awarded to any Respondent whose tax matters have not been declared by SARS to be in order.

7 VAT Registration

The valid VAT registration number must be stated here: _____ [if applicable].

8 Legal Compliance

The successful Respondent shall be in full and complete compliance with any and all applicable national and local laws and regulations.

9 Changes to Quotations

Changes by the Respondent to its submission will not be considered after the closing date and time.

10 Pricing

All prices must be quoted in South African Rand on a fixed price basis, excluding VAT.

11 Prices Subject to Confirmation

Prices quoted which are subject to confirmation will not be considered.

12 Negotiations

Transnet reserves the right to undertake post-tender negotiations with selected Respondents or any number of shortlisted Respondents.

13 Binding Offer

Any Quotation furnished pursuant to this Request shall be deemed to be an offer. Any exceptions to this statement must be clearly and specifically indicated.

14 Disclaimers

Transnet is not committed to any course of action as a result of its issuance of this RFQ and/or its receipt of a Quotation in response to it. Please note that Transnet reserves the right to:

- modify the RFQ's goods / service(s) and request Respondents to re-bid on any changes;
- reject any Quotation which does not conform to instructions and specifications which are detailed herein;
- disqualify Quotations submitted after the stated submission deadline;
- not necessarily accept the lowest priced Quotation;
- reject all Quotations, if it so decides;
- place an order in connection with this Quotation at any time after the RFQ's closing date;
- award only a portion of the proposed goods / service/s which are reflected in the scope of this RFQ;
- split the award of the order/s between more than one Supplier/Service Provider; or
- make no award at all.

Transnet reserves the right to award business to the highest scoring bidder/s unless objective criteria justify the award to another bidder.

15 Transnet's supplier integrity pact

Transnet's Integrity Pact requires a commitment from suppliers and Transnet that they will not engage in any corrupt and fraudulent practices, anti-competitive practices; and act in bad faith towards each other. The Integrity Pact also serves to communicate Transnet's Gift Policy as well as the remedies available to Transnet where a Respondent contravenes any provision of the Integrity Pact.

Respondents are required to familiarise themselves with the contents of the Integrity Pact which is available on the Transnet Internet site [www.transnet.net/Tenders/Pages/default.aspx] or on request. Furthermore, Respondents are required to certify that they have acquainted themselves with all the documentation comprising the Transnet Integrity Pact and that they fully comply with all the terms and conditions stipulated in the Transnet Supplier Integrity Pact as follows:

YES		NO	
------------	--	-----------	--

Should a Respondent need to declare previous transgressions or a serious breach of law in the preceding 5 years as required by Annexure A to the Integrity Pact, such declaration must accompany the Respondent's bid submission.

16 Evaluation Criteria

Transnet will utilise the following criteria [not necessarily in this order] in choosing a Supplier/Service Provider, if so required:

Criterion/Criteria	Explanation
Administrative responsiveness	Completeness of response and returnable documents
Substantive responsiveness	Prequalification criteria, if any, must be met and whether the Bid materially complies with the scope and/or specification given.
Final weighted evaluation based on 90/10 preference point system as indicated in paragraph 4	<ul style="list-style-type: none"> Pricing and price basis [firm] - whilst not the sole factor for consideration, competitive pricing and overall level of unconditional discounts¹ will be critical B-BBEE status of company - Preference points will be awarded to a bidder for attaining the B-BBEE status level of contribution in accordance with the table indicated in Annexure A.

17 Validity Period

Transnet desires a validity period of 90 [ninety] days from the closing date of this RFQ.

This RFQ is valid until _____.

18 Banking Details

BANK: _____

BRANCH NAME / CODE: _____

ACCOUNT HOLDER: _____

ACCOUNT NUMBER: _____

19 Company Registration

Registration number of company / C.C. _____

Registered name of company / C.C. _____

20 Disclosure of Prices Quoted

Respondents must indicate here whether Transnet may disclose their quoted prices and conditions to other Respondents:

YES NO

21 Returnable Documents

Returnable Documents means all the documents, Sections and Annexures, as listed in the tables below.

a) Respondents are required to submit with their Quotations the **mandatory Returnable Documents**, as detailed below.

¹ Only unconditional discounts will be taken into account during evaluation. A discount which has been offered conditionally will, despite not being taken into account for evaluation purposes, be implemented when payment is effected.

Failure to provide all these Returnable Documents at the Closing Date and time of this RFQ will result in a Respondent's disqualification. Respondents are therefore urged to ensure that all these Documents are returned with their Quotations.

All Sections, as indicated in the footer of each page, must be signed, stamped and dated by the Respondent. Please confirm submission of these mandatory Returnable Documents by so indicating [Yes or No] in the table below:

Mandatory Returnable Documents	Submitted [Yes or No]
SECTION 2 : Quotation Form	
CIDB Registration Certificate (SH 3)	
C Green Certificate	
Department of Agriculture certificate for pest control	

- b) In addition to the requirements of section (a) above, Respondents are further required to submit with their Quotations the following **essential Returnable Documents** as detailed below.

Failure to provide all these Returnable Documents may result in a Respondent's disqualification. Respondents are therefore urged to ensure that all these documents are returned with their Quotations.

All Sections, as indicated in the footer of each page, must be signed, stamped and dated by the Respondent. Please confirm submission of these essential Returnable Documents by so indicating [Yes or No] in the table below:

Essential Returnable Documents	Submitted [Yes or No]
SECTION 1 : Notice to Bidders	
- Valid and original B-BBEE Verification Certificate or certified copy thereof [Large Enterprises and QSEs] Note: failure to provide a valid B-BBEE Verification Certificate at the closing date and time of the RFQ will result in an automatic score of zero for preference	
- Valid and original B-BBEE certificate/sworn affidavit or certified copy thereof from auditor, accounting officer or SANAS accredited Verification Agency [EMEs] Note: failure to provide a valid B-BBEE Verification Certificate at the closing date and time of the RFQ will result in an automatic score of zero being allocated for preference	
- In the case of Joint Ventures, a copy of the Joint Venture Agreement or written confirmation of the intention to enter into a Joint Venture Agreement	
- Original valid Tax Clearance Certificate [Consortia / Joint Ventures must submit a separate Tax Clearance Certificate for each party]	
SECTION 3 : Standard Terms and Conditions of Contract for the Supply of Goods to Transnet	
SECTION 4 : Vendor Application Form	
- Original cancelled cheque or bank verification of banking details	

Respondent's Signature

Date & Company Stamp

Essential Returnable Documents	Submitted [Yes or No]
- Certified copies of IDs of shareholder/directors/members [as applicable]	
- Certified copies of the relevant company registration documents from Companies and Intellectual Property Commission (CIPC)	
- Certified copies of the company's shareholding/director's portfolio	
- Entity's letterhead	
- Certified copy of VAT Registration Certificate [RSA entities only]	
- Certified copy of valid Company Registration Certificate [if applicable]	
- A signed letter from Respondent's auditor or accountant confirming most recent annual turnover figures	
SECTION 5 : Project Specification	
Part A : Special Conditions	
Part B : Particular Specifications	
Quality Specifications	
Written Instruction Form	
Quotation Authority Form (Annexure 1)	
SECTION 6 : Safety Arrangements Act 85 of 1993 Regulations (E4E)	
SECTION 7 : Railway Lines and High Voltage Equipment (E7/1)	
ANNEXURE A – B-BBEE Preference Points Claim Form	
Valid Letter of Goods Standing/Compensation for Occupational Injuries and Diseased Act	

.....
Respondent's Signature

.....
Date & Company Stamp

Section 2 QUOTATION FORM

I/We _____
hereby offer to supply the goods/services at the prices quoted in the Price Schedule below, in accordance with the conditions related thereto.

I/We agree to be bound by those terms and conditions in:

- the Standard Terms and Conditions for the Supply of Goods or Services to Transnet [Section 3 hereof]; and
- any other standard or special conditions mentioned and/or embodied in this Request for Quotation.

I/We accept that unless Transnet should otherwise decide and so inform me/us, this Quotation [and, if any, its covering letter and any subsequent exchange of correspondence], together with Transnet's acceptance thereof shall constitute a binding contract between Transnet and me/us.

I/We further agree that if, after I/we have been notified of the acceptance of my/our Quotation, I/we fail to deliver the said goods/service/s within the delivery lead-time quoted, Transnet may, without prejudice to any other legal remedy which it may have, cancel the order and recover from me/us any expenses incurred by Transnet in calling for Quotations afresh and/or having to accept any less favourable offer.

Price Schedule

I/We quote as follows for the goods required, on a "delivered nominated destination" basis, **excluding VAT**:

ITEM	DESCRIPTION	SIZE / UNIT	RATE	R	C
1	Travelling Beyond 10Km from Bloemfontein Station (One Way)	Km	Per Km		
2	Spray plants with full leave cover (Confront or similar herbicide) (Min 10 Trees)	0 – 1 Mt in height	Per Tree		
3	Cut to 1m and treat small tree and remove tree s (Min 5 Trees)	1 – 4 Mt in height	Per Tree		
4	Cut to 600mm and treat medium tree and remove tree (Min 1 Trees)	4 – 9Mt in height	Per Tree		
5	Cut to 600mm and treat medium tree near power lines, railway lines, buildings and fences and remove (Min 1 Tree)	4 – 9 Mt in height	Per Tree		
6	Cut to 600mm and treat big tree and remove (Min 1 Tree)	9 – 20 Mt in height	Per Tree		
7	Cut to 600mm and treat big tree near power line, railway line, buildings and fences and remove tree (Min 1 Tree)	9 – 20 Mt in height	Per Tree		
8	Pruning of trees (Up to 2Mt from ground level)	Tree	Ea		
9	Rate for cutting and removing of grass (Min 200M ²)	M ²	M ²		

Respondent's Signature

Date & Company Stamp

10	Hoeing (6Mt radius around buildings)	M ²	M ²		
		SUB TOTAL			
		ADD 14% VAT			
		TOTAL TENDER PRICE			

TOTAL TENDER PRICE IN WORDS:

.....

.....

Delivery Lead-Time from date of purchase order : _____ **[days/weeks]**

Notes to Pricing:

Notes to Pricing:

- a) All Prices must be quoted in South African Rand, exclusive of VAT
- b) To facilitate like-for-like comparison bidders must submit pricing strictly in accordance with this price schedule and not utilise a different format. Deviation from this pricing schedule could result in a bid being disqualified.
- c) Please note that should you have offered a discounted price(s), Transnet will only consider such price discount(s) in the final evaluation stage if offered on an unconditional basis.

PREVIEW COPY ONLY

.....
Respondent's Signature

.....
Date & Company Stamp

Section 3

STANDARD TERMS AND CONDITIONS FOR THE SUPPLY OF GOODS OR SERVICES TO TRANSNET

A Supplier/Service Provider shall be obliged to adhere to the Standard Terms and Conditions for the Supply of Goods and Services to Transnet as expressed hereunder. Should the Respondent find any condition(s) unacceptable, it should indicate which condition(s) is/are unacceptable and offer an alternative(s). A Quotation submitted by a Respondent will be subjected to review and acceptance or rejection of its proposed contractual terms and conditions by Transnet's Legal Counsel, prior to consideration for an award of business.

1 SOLE AGREEMENT

Unless otherwise agreed in writing, these terms [Terms and each Term] and Transnet's purchase order(s) [Order or Orders] represent the only conditions upon which Transnet SOC Ltd [Transnet] procures goods [the Goods] or services [the Services] specified in the Order from the person to whom the Order is addressed [the Supplier/Service Provider]. Transnet does not accept any other conditions which the Supplier/Service Provider may specify, unless otherwise agreed to by Transnet in writing. In the event of any inconsistency between these Terms and any Order, these Terms shall take precedence.

2 CONFORMITY WITH ORDER

Goods/Services shall conform strictly with the Order. The Supplier/Service Provider shall not vary the quantities specified and/or the specification, if any, stipulated in the Order, without the prior written consent of Transnet. The Supplier/Service Provider warrants that the Goods/Services shall be fit for their purpose and of satisfactory quality.

3 DELIVERY AND TITLE

- 3.1 The delivery dates and addresses are those in the Order. Time shall be of the essence in respect of the Supplier's/Service Provider's obligations under the Order.
- 3.2 The Supplier/Service Provider will not be excused for delay in delivery or performance except due to circumstances outside its control and then only subject to the Supplier/Service Provider having notified Transnet in writing on becoming aware of such circumstances. Transnet may terminate an Order, in whole or in part, without incurring any liability to the Supplier/Service Provider if such a delay becomes, in Transnet's absolute opinion, significant.
- 3.3 If on delivery, the Goods/Services do not conform to the Order, Transnet may reject the Goods/Services and the Supplier/Service Provider shall promptly rectify any defects or in Transnet's opinion, supply appropriate replacement Goods/Services at the Supplier's/Service Provider's expense within the specified delivery times, without any liability due by Transnet.

4 PRICE AND PAYMENT

- 4.1 Prices specified in an Order cannot be increased. Payment for the Goods/Services shall be made by Transnet against an original undisputed invoice(s) [a Tax Invoice], supporting documentation and month-end statement from the Supplier/Service Provider. Tax Invoices plus supporting documentation shall be posted to the address shown in the Order.

4.2 Payment of the Supplier's/Service Provider's valid Tax Invoice(s) will be made by Transnet in the South African currency and on the terms stated in the Order, the standard payment terms being 30 [thirty] days from date of receipt by Transnet of a month-end statement, unless otherwise agreed to in writing. Transnet shall arrange for payment of such Tax Invoices and any pre-authorised additional expenses incurred, provided that the authorised expenses are supported by acceptable documentary proof of expenditure incurred [where this is available]. Any amounts due in terms of these Terms shall be paid to the Supplier/Service Provider, taking into account any deduction or set-off and bank charges.

5 PROPRIETARY RIGHTS LIABILITY

If any allegations should be made or any claim asserted against Transnet that ownership of, or any act or omission by Transnet in relation to Goods/Services or any written material provided to Transnet relating to any Goods/Services or pursuant to an Order being a violation or infringement of any third party's contractual, industrial, commercial or intellectual property rights including but not limited to any patent, registered design, design right, trade mark, copyright or service mark on any application thereof, the Supplier/Service Provider hereby indemnifies Transnet against and hold it harmless from any and all losses, liabilities, costs, claims, damages and expenses [including any legal fees] arising directly or indirectly from such allegation or claim provided that this indemnity shall not apply where the allegation or claim arises solely as a result of the Supplier/Service Provider following a design or process originated and furnished by Transnet. The Supplier/Service Provider shall either

- a) procure for Transnet the right to continue using the infringing Goods; or
- b) modify or replace the Goods/Services so that they become non-infringing,

provided that in both cases the Goods/Services shall continue to meet Transnet's requirements and any specifications stipulated in the Order. Should neither option be possible, the Supplier/Service Provider may remove, with Transnet's prior written consent, such Goods/Services and will pay to Transnet a sum equivalent to the purchase price. If Transnet refuses to give such consent, the Supplier/Service Provider shall have no liability in respect of any continued use of the infringing Goods/Services after Supplier's/Service Provider's prior written request to remove the same.

6 PROPRIETARY INFORMATION

All information which Transnet has divulged or may divulge to the Supplier/Service Provider and any information relating to Transnet's business which may have come into the Supplier's/Service Provider's possession whilst carrying out an Order, and the existence of the Order, shall be treated by the Supplier/Service Provider as confidential information and shall not, without Transnet's prior written consent, be disclosed to any third party, or be used or copied for any purposes other than to perform the Order. This clause does not apply to information which is public knowledge or available from other sources other than by breach of this Term. Upon request by Transnet, the Supplier/Service Provider shall return all materials issued pursuant to the Order and, pending this, shall protect Transnet's rights in any such materials. Such confidential information shall at all material times be the property of Transnet.

7 PUBLICITY

The Supplier/Service Provider shall not name Transnet or use its trademarks, service marks [whether registered or not] or Goods in connection with any publicity without Transnet's prior written consent.

8 TERMINATION OF ORDER

- 8.1 Transnet may cancel an Order in whole or in part at any time upon at least 7 [seven] days' written notice to the Supplier/Service Provider, or when there is a change in control of the Supplier/Service Provider or the Supplier/Service Provider commits any serious breach or any repeated or continued material breach of its obligations under these Terms and/or Order or shall have been guilty of conduct tending to bring itself into disrepute, on written notice to the Supplier/Service Provider when such work on the Order shall stop.
- 8.2 Transnet shall pay the Supplier/Service Provider a fair and reasonable price for justified work in progress, where such price reflects only those costs not otherwise recoverable by the Supplier/Service Provider, at the time of termination, and the Supplier/Service Provider shall give Transnet full assistance to check the extent of such work in progress. Payment of such price shall be in full and final satisfaction of any claims arising out of such termination and upon such payment the Supplier/Service Provider shall deliver to Transnet all work, including any materials, completed or in progress. The sum payable to the Supplier/Service Provider under this clause will not in any event exceed the total amount that would have been payable to the Supplier/Service Provider had the Order not been terminated.
- 8.3 In the event of termination the Supplier/Service Provider must submit all claims within 2 [two] months of termination after which time claims will only be met in what Transnet considers exceptional circumstances.
- 8.4 If the Goods or Services are not provided in accordance with an Order, the Order shall be deemed terminated and the Supplier/Service Provider shall compensate Transnet for any costs incurred in obtaining substitute Goods or any damage caused due to the failure or delay in the delivery.

9 ACCESS

The Supplier/Service Provider shall be liable for the acts, omissions and defaults of its personnel or agents who, for the purposes of the Order, shall be treated as if they are the Supplier's/Service Provider's employees. The Supplier/Service Provider shall ensure that any such personnel or agents, whilst on Transnet's premises, shall comply with Transnet's health and safety, security and system security rules and procedures as and where required.

10 WARRANTY

The Supplier/Service Provider warrants that it is competent to supply the Goods/Services in accordance with these Terms to the reasonable satisfaction of Transnet and that all Goods/Services delivered under the Order: (a) conform and comply in all relevant legislation, standards, directives and orders related to [inter alia] the Services in force at the time of delivery, and to any specifications referred to in the Order; (b) will not cause any deterioration in the functionality of any Transnet equipment; and (c) do not infringe any third party rights of any kind. The Supplier/Service Provider hereby indemnifies Transnet against all

losses, liabilities, costs, claims, damages, expenses and awards of any kinds incurred or made against Transnet in connection with any breach of this warranty.

11 **INSOLVENCY**

If the Supplier/Service Provider shall have a receiver, manager, administrator, liquidator or like person appointed over all or any part of its assets or if the Supplier/Service Provider compounds with its creditors or passes a resolution for the writing up or administration of the Supplier/Service Provider, Transnet is at liberty to terminate the Order or Orders forthwith, or at its option, to seek performance by any such appointed person.

12 **ASSIGNMENT**

The Supplier/Service Provider shall not assign its obligations under an Order without Transnet's prior written consent, which consent shall not be unreasonably withheld or delayed.

13 **NOTICES**

Notices under these Terms shall be delivered by hand to the relevant addresses of the parties in the Order or may be served by facsimile or by email, in which event notice shall be deemed served on acknowledgement of receipt by the recipient.

14 **LAW**

Orders shall be governed by and interpreted in accordance with South African law and any disputes arising herein shall be subject to South African arbitration under the rules of the Arbitration Foundation of South Africa, which rules are deemed incorporated by reference in this clause. The reference to arbitration shall not prevent Transnet referring the matter to any South African courts, having jurisdiction, to which the Supplier/Service Provider hereby irrevocably submits but without prejudice to Transnet's right to take proceedings against the Supplier/Service Provider in other jurisdictions and/or obtaining interim relief on an urgent basis from a court of competent jurisdiction pending the decision in other courts or from instituting in any court of competent jurisdiction any proceedings for an interdict or any other injunctive relief. If the Supplier/Service Provider does not have a registered office in the South Africa it will at all times maintain an agent for service of process in South Africa and shall give Transnet the name and address of such agent as such may be amended, in writing, from time to time.

15 **GENERAL**

Completion or termination of an Order shall be without prejudice to any Term herein which by its nature would be deemed to continue after completion or termination, including but not limited to clauses **Error! Reference source not found., Error! Reference source not found., Error! Reference source not found., Error! Reference source not found.** and **Error! Reference source not found.** Headings are included herein for convenience only. If any Term herein be held illegal or unenforceable, the validity or enforceability of the remaining Terms shall not be affected. No failure or delay by Transnet to enforce any rights under these Terms will operate as a waiver thereof by Transnet. All rights and remedies available to either party under these Terms shall be in addition to, not to the exclusion of, rights otherwise available at law.

16 COUNTERPARTS

These Terms and conditions may be signed in any number of counterparts, all of which taken together shall constitute one and the same instrument. Any party may enter into this agreement by signing any such counterpart.

PREVIEW COPY ONLY

.....
Respondent's Signature

.....
Date & Company Stamp

By signing this RFQ document, the Respondent is deemed to acknowledge that he/she has made himself/herself thoroughly familiar with all the conditions governing this RFQ, including those contained in any printed form stated to form part hereof and Transnet SOC Ltd will recognise no claim for relief based on an allegation that the Respondent overlooked any such condition or failed to properly take it into account for the purpose of calculating quoted prices or otherwise.

SIGNED at _____ on this ____ day of _____ 20____

.....
SIGNATURE OF RESPONDENT'S AUTHORISED REPRESENTATIVE

NAME: _____

DESIGNATION: _____

REGISTERED NAME OF COMPANY: _____

PHYSICAL ADDRESS:

Respondent's contact person: *[Please complete]*

Name	:	_____
Designation	:	_____
Telephone	:	_____
Cell Phone	:	_____
Facsimile	:	_____
Email	:	_____
Website	:	_____

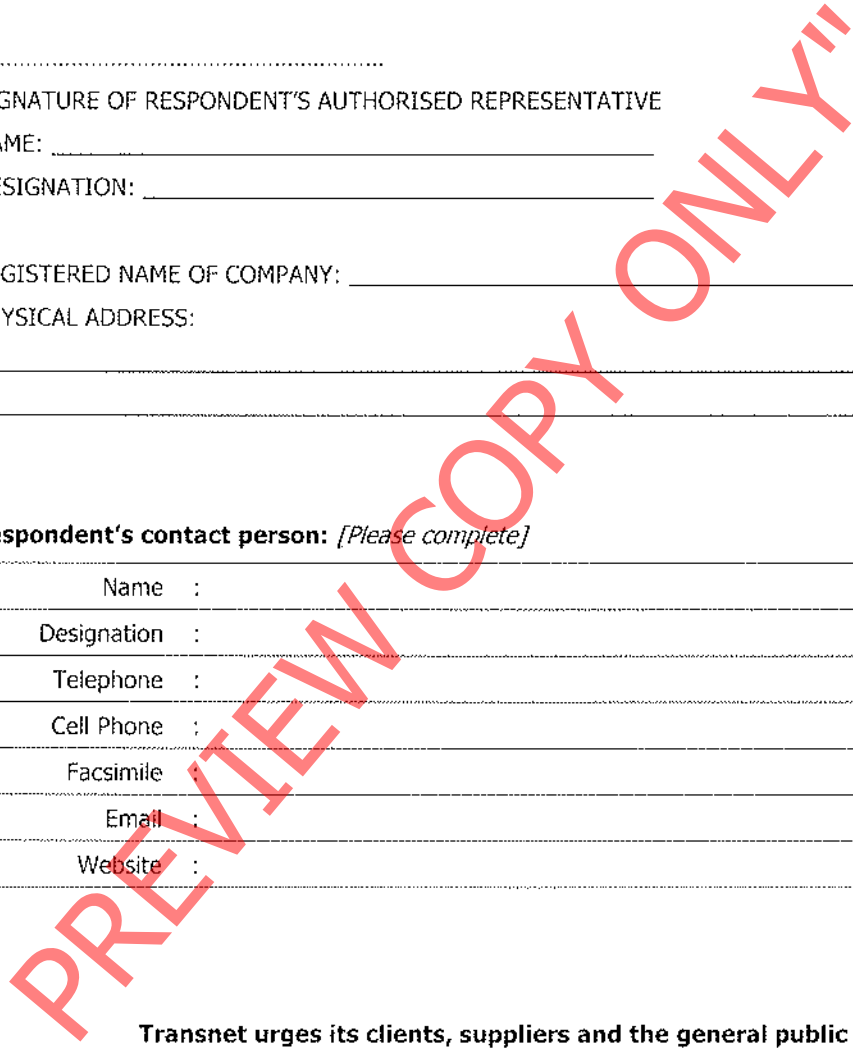

Transnet urges its clients, suppliers and the general public to report any fraud or corruption to TIP-OFFS ANONYMOUS : 0800 003 056

.....
Respondent's Signature

.....
Date & Company Stamp

Section 4

VENDOR APPLICATION FORM

Transnet Supplier Declaration/Application

The Financial Director or Company Secretary

Transnet Vendor Management has received a request to load your company on to the Transnet vendor database. Please furnish us with the following to enable us to process this request:

1. Complete the "Supplier Declaration Form" (SDF) on page 2 of this letter
2. **Original** cancelled cheque **OR** letter from the bank verifying banking details (**with bank stamp**)
3. **Certified** copy of Identity document of Shareholders/Directors/Members (where applicable)
4. **Certified** copy of certificate of incorporation, CM29 / CM9 (name change)
5. **Certified** copy of share Certificates of Shareholders, CK1 / CK2 (if CC)
6. A letter with the company's letterhead confirming physical and postal addresses
7. **Original** or **certified** copy of SARS Tax Clearance certificate and Vat registration certificate
8. A signed letter from the Auditor / Accountant confirming most recent annual turnover and percentage black ownership in the company **AND/OR** BBBEE certificate and detailed scorecard from an accredited rating agency (SANAS member).
 - **Failure to submit the above documentation will delay the vendor creation process.**
 - *Where applicable, the respective Transnet business unit processing your application may request further information from you. E.g. proof of an existence of a Service/Business contract between your business and the respective Transnet business unit etc.*

IMPORTANT NOTES:

- a) **If your annual turnover is less than R5 million**, then in terms of the DTI codes, you are classified as an Exempted Micro Enterprise (EME). If your company is classified as an EME, please include in your submission, a signed letter from your Auditor / Accountant confirming your company's most recent annual turnover is less than R5 million and percentage of black ownership and black female ownership in the company **AND/OR** BBBEE certificate and detailed scorecard from an accredited rating agency (e.g. permanent SANAS Member), should you feel you will be able to attain a better BBBEE score.
- b) **If your annual turnover is between R5 million and R35million**, then in terms of the DTI codes, you are classified as a Qualifying Small Enterprise (QSE) and you claim a specific BBBEE level based on any 4 of the 7 elements of the BBBEE score-card, please include your BEE certificate in your submission as confirmation of your status.
NB: BBBEE certificate and detailed scorecard should be obtained from an accredited rating agency (e.g. permanent SANAS Member).
- c) **If your annual turnover is in excess of R35million**, then in terms of the DTI codes, you are classified as a Large Enterprise and you claim a specific BEE level based on all seven elements of the BBBEE generic score-card. Please include your BEE certificate in your submission as confirmation of your status.
NB: BBBEE certificate and detailed scorecard should be obtained from an accredited rating agency (permanent SANAS Member).
- d) **To avoid PAYE tax being automatically deducted from any invoices received from you**, you must also contact the Transnet person who lodged this request on your behalf, so as to be correctly classified in terms of Tax legislation.
- e) Unfortunately, **No payments can be made to a vendor** until the vendor has been registered, and no vendor can be registered until the vendor application form, together with its supporting documentation, has been received and processed.
- f) **Please return the completed Supplier Declaration Form (SDF) together with the required supporting documents mentioned above to the Transnet Official who is intending to procure your company's**
- g) **services/products in order that he/she should complete and Internal Transnet Departmental Questionnaire before referring the matter to the appropriate Transnet Vendor Master Office.**

.....
Respondent's Signature

.....
Date & Company Stamp

Supplier Declaration Form

Company Trading Name							
Company Registered Name							
Company Registration Number Or ID Number If A Sole Proprietor							
Form of entity	CC	Trust	Pty Ltd	Limited	Partnership	Sole Proprietor	
VAT number (if registered)							
Company Telephone Number							
Company Fax Number							
Company E-Mail Address							
Company Website Address							
Bank Name				Bank Account Number			
Postal Address						Code	
Physical Address						Code	
Contact Person							
Designation							
Telephone							
Email							
Annual Turnover Range (Last Financial Year)	< R5 Million	R5-35 million	> R35 million				
Does Your Company Provide	Products	Services	Both				
Area Of Delivery	National	Provincial	Local				
Is Your Company A Public Or Private Entity	Public		Private				
Does Your Company Have A Tax Directive Or IRP30 Certificate	Yes		No				
Main Product Or Service Supplied (E.G.: Stationery/Consulting)							
BEE Ownership Details							
% Black Ownership	% Black women ownership	% Disabled person/s ownership					
Does your company have a BEE certificate	Yes	No					
What is your broad based BEE status (Level 1 to 9 / Unknown)							
How many personnel does the firm employ	Permanent	Part time					
Transnet Contact Person							
Contact number							
Transnet operating division							
Duly Authorised To Sign For And On Behalf Of Firm / Organisation							
Name		Designation					
Signature		Date					
Stamp And Signature Of Commissioner Of Oath							
Name		Date					
Signature		Telephone No.					

Respondent's Signature

Date & Company Stamp

**SECTION 5
RFQ NUMBER**

**PROVISION OF AS & WHEN CONTROL OF VEGETATION INCLUDING TREES,BUSH AND CUTTING
OF GRASS IN THE BLOEMFONTEIN REGION
FOR A PERIOD OF 24 MONTHS
SPECIAL CONDITIONS PART A**

1. SCOPE OF REQUIREMENTS

This contract covers **the control of vegetation, including cutting of trees, pruning of trees, hoeing and cutting of grass and bush, on a basis of as and when required in a radius of 450 km of Bloemfontein** by means of portable and/or other approved equipment or methods on Transnet property. This work is to be done in the geographical area controlled by the Property Manager, Kimberley Region, to the extent that vegetation treated chemically or mechanically or otherwise in terms of this contract is kept under control, as defined, for the period specified herein. The work shall be done in normal working hours from 07:00 to 17:00 from Mondays to Fridays (excluding public holidays).

The performance due by the service provider(s) shall include any work arising from or incidental to the above or required of the service provider(s) for the proper completion of the contract in accordance with the true meaning and intent of the contract documents.

The service provider(s) shall obtain his/her own information regarding species, occurrence and extent of vegetation to be controlled in order to comply with the required standard

2. TO BE SUPPLIED BY THE CONTRACTOR

Except where otherwise specified, the Contractor shall supply all labour, transport, plant, equipment, tools, services required for the carrying out and completion of the work included in this contract.

3. ELECTRICITY AND WATER

Water and electricity will be supplied free of charge by Transnet. A continuous supply of water and electricity can however not be guaranteed. The Contractor shall at his own cost arrange for connections and extensions (if necessary) to existing supplies and for the removal of these connections and extensions on completion of the contract.

.....
Respondent's Signature

.....
Date & Company Stamp

4 CONSTRUCTION SITE

The Contractor must view the site and attend the compulsory site inspection before tendering.

5 DURATION OF CONTRACT

The contract values will not exceed **R1 900 000.00 (One Million NINE Hundred Thousand Rand)** and the duration will not exceed **24months**, whichever occurs first.

The period commences from the date when approval was granted to the Contractor to proceed with the work and includes all weekends and public holidays.

Should the cumulative amount spent approach the **R1 900 000.00** limit, the issue of work will be curtailed.

Transnet reserves the right to terminate the contract at any time should the use of the contract no longer be required.

6 MAINTENANCE PERIOD (GUARANTEE)

The contractor must, at his own expense, make good to the satisfaction of the Maintenance Supervisor all workmanship which may manifest itself within a period of **six months** after completion of work.

7 PENALTIES

Transnet retains the right to cancel any order and have work, which is not attended to as in the specification, executed by others, without prior notice and recover the difference in cost, if any, from the contractor.

8 LABOUR

The sole responsibility for the work as specified in the particular specification shall rest entirely with the Contractor, who shall be required to undertake rectification of any defects, which become apparent within the period as defined above. The Contractor shall make good to the satisfaction of Transnet any defects which may arise during inspection.

9 PAYMENT

When making a claim for payment, the Contractor shall submit an informal claim for the consideration of the Manager. Only upon agreement being reached on the amount to be included in the payment certificate, will the Contractor be required to submit a complete and correct VAT invoice. Payment will be effected on or before the end of the calendar month following the calendar month in which the work was performed.

.....
Respondent's Signature

.....
Date & Company Stamp

TRAVELING

10

The price shall be inclusive of traveling within 10 Km radius from the station. However, if the work is outside this 10 km radius then the contractor shall be compensated for this as per the Schedule of Rates and Prices. Note this rate is from the 10 km radius to the requested work site and the price is inclusive of the return trip (**only one way shall be paid for**).

Please note: A maximum of 23 interim payments (based on work completed on a monthly basis, after the receipt of a VAT invoice) The Contractor must indicate on his Tax Invoice Transnet's reference number, description of the work, Labour amount, kilometres travelled and the amount claimed), and a final payment will be made.

VAT

Rates shall be quoted exclusive of Value Added Tax. Provision is made in the Summary of Prices for the lump-sum addition of Value Added Tax.

11 SUMMARY OF PRICES

Tenderers must complete the Summary of Prices for the work in ink.

12 SAFETY ON WORK SITE (ACT NUMBER 85 OF 1993) ENVIRONMENT CONSERVATION ACT.(ACT No.73 OF 1989)

For the purposes of the Occupational Health and Safety Act, (Act Number 85 of 1993) and the Environment Conservation Act, (Act No.73 of 1989) the site is transferred, for the duration of the contract, to the control of the Contractor as if it is his property. As employer, he is in every respect responsible for the compliance with the provisions of these Acts, as well as the application of General Administrative Regulation 13 to the employees of Transnet who visit the site.

13 DAMAGE TO PROPERTY AND/OR SERVICES

The contractor shall take adequate precaution against damage to existing assets and injury to persons during the course of the contract. The successful tenderer will be responsible for the repairs and/or the costs incurred in such repairs to any damages caused to Transnet's property by the successful tenderer's staff while carrying out the required work.

14 SUPERVISION

The Manager will provide overall superintendence of the work and may direct the Contractor in terms of the provisions of the contract.

.....
Respondent's Signature

.....
Date & Company Stamp

Transnet will notify the successful contractor, in writing, of the name of the Maintenance Supervisor/s who will supervise and take charge of the contract. The Contractor must at all times, only take instructions from the appointed Maintenance Supervisor/s and (Manager) and nobody else.

The Contractor must be in possession of or have access to a cellular phone and a facsimile machine.

15 MATERIALS

Only materials of the best quality (SANS/SABS approved) are to be used in the execution of the contract and the work is to be performed in a proper workmanlike manner to the full satisfaction of Transnet.

16 CANCELLATION OF CONTRACT

In the event of non-performance and/or non-adherence to the specifications by the Contractor, Transnet reserves the right to terminate the contract immediately.

17 AMENDMENTS AND/OR ADDITIONS

Transnet reserves the right to add or withdraw any part of the work specified at any time. No amendments, variations and/or additions to the contract shall, however, be of any force or effect unless reduced to writing and signed by both parties.

18 HOUSING OF EMPLOYEES

Accommodation of the Contractor's employees on site will not be permitted and the Contractor shall make his own arrangements.

19 TOILET FACILITIES

Use of existing toilet facilities will be permitted.

20 ESCALATION OF COST

Escalation of 12% will be allowed after the first 12 month

20 WAGE REGULATING MEASURES

The Contractor shall acquaint himself with any relevant wage regulating measure and/or statutory enactment which may be in force or may be contemplated, and which will affect conditions of employment during the progress of the contract, and he shall give effect to the provisions of such wage regulating measure and/or statutory enactment as they come into force.

21 SUBLETTING OF THE CONTRACT

The successful service provider(s) shall not be permitted to sublet the contract. Only persons directly employed by the service provider(s) shall carry out the work.(The respondent or a representative must

.....
Respondent's Signature

.....
Date & Company Stamp

comply, which means if the owners don't comply, another person who works for the company should comply..Not a representative of another company which make that Sub-Contracting

22 SUBSTANCE ABUSE TESTING

The OH Act (Act 85 of 1993) clearly states in the Safety Regulations no. **2A "INTOXICATION" An employer or user, as the case may be, shall not permit any person who appears to be under the influence of intoxicating liquor or drugs, to enter or remain at a workplace".** Transnet Freight Rail enforces this legislation by means of its Substance Abuse Policy, and therefore reserves the right to do substance abuse testing on anyone who enters their premises.

23 GENERAL

All activities between Contractors and Transnet personnel will be co-ordinated through the Manager in charge.

For more information contact Mr. L G Vermaak at telephone (053) 838-3304.

The lowest or only tender will not necessarily be accepted.

PREVIEW COPY ONLY

.....
Respondent's Signature

.....
Date & Company Stamp

PARTICULAR SPECIFICATION PART B**25. DEFINITIONS**

Control is achieved when;

- a. No new growth, such as seedlings or saplings, of woody plant material and reeds, of any height, occur,
- b. Plant material, other than woody material and reeds, such as grasses and herbaceous plants are to remain alive to prevent soil erosion.
- c. Cut woody plant, i.e. trees, bush, noxious weed and plant invaders, as well as reeds cease to exist.
- d. Declared weeds means category 1 plants and declared invader plants means category 2 and 3 plants proclaimed under the Conservation of Agricultural Resources Act, Act No. 43 of 1983, including amendments (GN Regulation 1048 of 25/05/1984 amended by GH Regulation 280 of 30/03/2001) thereto.
- e.

26. METHOD OF VEGETATION MAINTENANCE AND CONTROL

The service provider(s) methods shall provide rapid and effective control and maintenance in all areas. Techniques, and programming employed shall therefore be directed at this aim.

Where plant material, stipulated in the Specification, is severely damaged or destroyed due to negligence on the part of the service provider(s), the service provider(s) shall be held responsible for the full reinstatement thereof.

27. PROCEDURE TO BE FOLLOWED.

The Project Manager will issue a written instruction to the service provider(s) before work can commence. Where work is of an emergency nature, the Project Manager may give a verbal instruction that must be confirmed in writing. No work must be performed without a **reference number**.

28. WORK TO BE DONE

- a. The service provider(s) shall have a competent team leader to take charge of the work team
- b. Grass areas and grass verges shall be hoed around buildings (radius not less than 6m).
- c. In areas as pointed out, the grass must be cut to a maximum growth height of 0,05 metres
- d. Decorative trees shall be pruned in such a manner to enable a person to walk underneath without hindrance at 2 meters above ground level.
- e. All cut, dead or dry remains of any vegetation, refuse generated, general refuse, i.e. paper and paper products, plastic and plastic products, building rubble, containers and discarded matter within the maintained area are completely removed from Transnet property to a designated municipal landfill site (This clause may vary from area to area and will be instructed by the Project Manager)

.....
Respondent's Signature

.....
Date & Company Stamp

- f. No burning of any kind will be allowed
- g. Cut back wood Prosopis and other trees and certain plant material, i.e. declared weeds and declared invader plants to a maximum height of 0.10 meter's and treat with Herbicide as specified so that the remaining stumps and growth cease to exist as living organisms or entities. (Tread with **GARLON* 480 EC** and diesel as specified).
- h. The Contractor shall not depart from the methods of vegetation control or minimum herbicide usage as specified without approval from the Project Manager or his/her deputy

29. **HERBICIDE / GARRLON* 480 EC**

- a. For the control of woody plants and weeds listed for forestry, grass pastures, industrial areas and sugarcane.

Mixing

- b. For foliar applications, half fill the spray tank with water and add the required quantity of **GARLON* 480 EC**. While filling the spray tank add **ACTIPRON SUPER** at the rate indicated below while maintaining constant agitation
- c. Where herbicides are to be used for stump treatment it is required that suitable colorant (**ECORED DYE**) be added to the herbicide or that an herbicide containing a colorant be used. Detail of the colorants, and with which products they are to be used, must be provided.

Application

Foliar Application

NOTE : ACTIPRON SUPER SHOULD BE ADDED AT A RATE OF 500ML/100 LITRES SPRAY MIX FOR ALL FOLIAR APPLICATIONS

- a. Use only on actively growing plants with full leaf cover
- b. Apply as a full cover spray to leaves and stems to the point of spray solution run-off.
- c. Do not apply to wet foliage.
- d. Avoid spray drift on to non-target plants.
- e. Rain after application will have no effect on efficacy (efficiency) provided the spray has dried on the target plants.
- f. Use a knapsack sprayer with a solid cone nozzle (e.g. Spraying Systems TG-1or equivalent type) that will ensure an even coverage of the target area. Maintain a constant pressure of between 200-250 kpa.

.....
Respondent's Signature

.....
Date & Company Stamp

Cut Stump

- g. Apply on the day of felling (within 30 minutes).
- h. Use solid cone nozzle tips (e.g. Spraying Systems TG-1, Delavan CE 1 or equivalent type) at 100 kpa, (low pressure).
- i. Apply mixture to the point of run-of according to directions for stump and cut stumps in the table below.

Basal Bark Treatment

(For plants with stem diameter up to 600 mm.)

- j. **GARLON* 480 EC** in diesel should not be applied to stems if surface is wet from rain or dew.
- k. Apply paintbrush or knapsack as a coarse, low-pressure spray using narrow angle solid cone nozzle. Apply all-round the basal stem or trunk of the woody plant from soil level to a height indicated (as per the manufacturer), as well as any exposed roots. In order to obtain satisfactory results a thorough wetting of the indicated area is imperative. Old or rough bark may require more mixture than young or smooth bark. In the case of multi-stemmed plants, each stem should be treated separately.

30. GENERAL

- a. The service provider(s) must not turn off any Electrical or water supply without obtaining permission from the Depot Manager.
- b. The service provider(s) will be responsible for his own measurements
- c. The premises shall be left perfectly clean after completion of the work, before payment will be made.
- d. The service provider(s) will supply all equipment and material.
- e. The service provider(s) shall include for the proper completion of the work as described and shall allow for all cost incurred.
- f. Contract specifications are to be read in conjunction with the minutes. The service provider(s) attention is drawn to the possibility of items being required varying from those on the specification. The cost of the requirements in the minutes is to be allowed for in the tender price.
- g. The service provider(s) will be responsible for obtaining the minutes of said meeting before specified closing date.

Please note

- h. A certified copy of the certificate issued by the Department of Agriculture to certify that the respondent or his/her representative (the representative must be employed by the successful bidder) is a pest control operator to handle weed killer chemicals in terms of Act 36 of 1947 must be supplied with contract document (See Names of Directors).

.....
Respondent's Signature

.....
Date & Company Stamp

WRITTEN INSTRUCTION FORM

FOR THE AS AND WHEN CONTROL OF VEGETATION INCLUDING TREES, BUSH AND CUTTING OF GRASS IN THE BLOEMFONTEIN REGION

FAULTS.

REFERENCE	(i) <u>PLACE</u>	DESCRIPTION	Asset no

COMMENTS:

Should the cumulative amount spent approach the **R1 900 000.00** limit, the issue of work will be curtailed.

**MAINTENANCE SUPERVISOR
REM TECHNICAL**

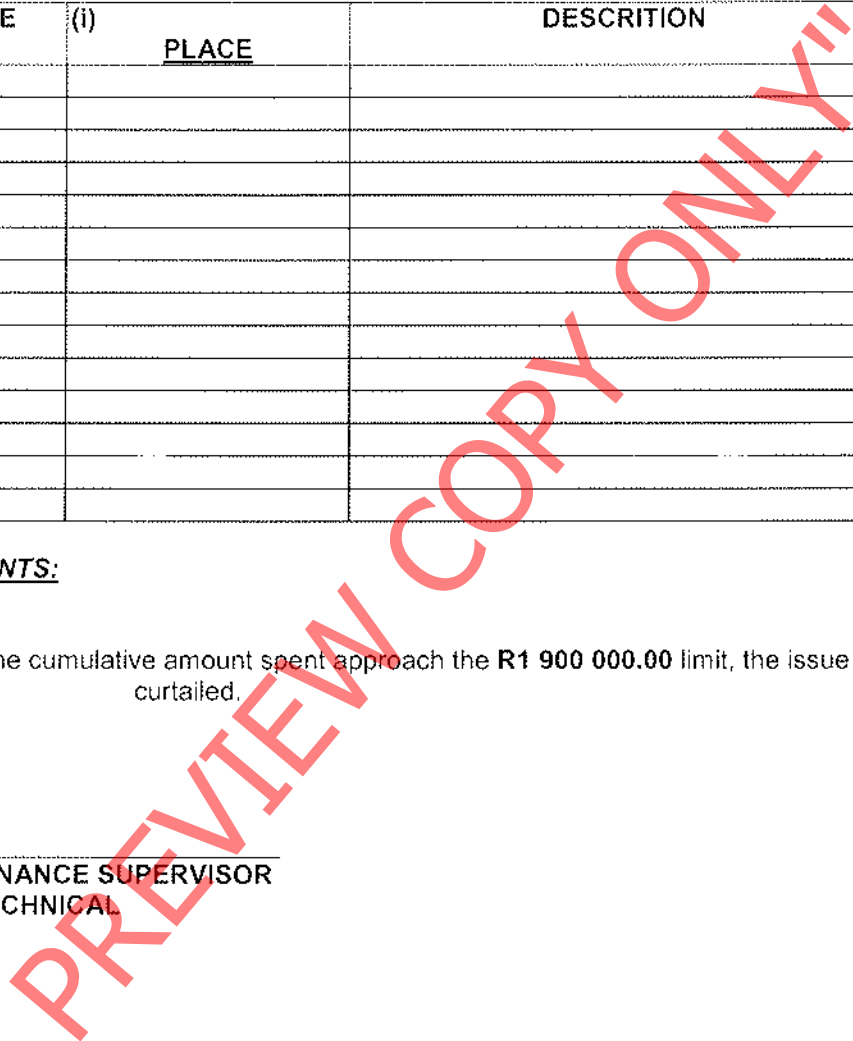

ESTIMATE OF TREE'S/GRASS TO BE CUT

ITEM	DESCRIPTION	SIZE / UNIT	RATE	UNITS
1	Travelling Beyond 10Km from Bloemfontein Station (One Way)	Km	Per Km	11690
2	Spray plants with full leave cover (Confront or similar herbicide) (Min 10 Trees)	0 – 1 Mt in height	Per Tree	759
3	Cut to 1m and treat small tree and remove trees (Min 5 Trees)	1 – 4 Mt in height	Per Tree	819
4	Cut to 600mm and treat medium tree and remove tree (Min 1 Tree)	4 – 9 Mt in height	Per Tree	1759
5	Cut to 600mm and treat medium tree near power lines, railway lines and buildings and remove tree (Min 1 Tree)	4 – 9 Mt in height	Per Tree	318
6	Cut to 600mm and treat big tree and remove tree (Min 1 Tree)	9 – 20 Mt in height	Per Tree	869
7	Cut to 600mm treat big tree near power line, railway line, buildings and fences and remove tree (Min 1 Tree)	9 – 20 Mt in height	Per Tree	335
8	Pruning of trees (Up to 2Mt from ground level)	Tree	Ea	172
9	Rate for cutting and removing of grass (Min 200M ²)	M ²	M ²	152890
10	Hoeing (6Mt radius around buildings)	M ²	M ²	2689

QUOTATION AUTHORITY FOR

ITEM	DESCRIPTION	SIZE / UNIT	RATE	UNITS	R / C
1	Travelling Beyond 10Km from Bloemfontein Station (One Way)	Km	Per Km		
2	Spray plants with full leave cover (Confront or similar herbicide) (Min 10 Trees)	0 – 1 Mt in height	Per Tree		
3	Cut to 1m and treat small tree and remove trees (Min 5 Trees)	1 – 4 Mt in height	Per Tree		
4	Cut to 500mm and treat medium tree and remove tree (Min 1 Tree)	4 – 9 Mt in height	Per Tree		
5	Cut to 600mm and treat medium tree near power lines, railway lines and buildings and remove tree (Min 1 Tree)	4 – 9 Mt in height	Per Tree		
6	Cut to 500mm and treat big tree and remove tree (Min 1 Tree)	9 – 20 Mt in height	Per Tree		
7	Cut to 500mm treat big tree near power line, railway line, buildings and fences and remove tree (Min 1 Tree)	9 – 20 Mt in height	Per Tree		
8	Pruning of trees (Up to 2Mt from ground level)	Tree	Ea		
9	Rate for cutting and removing of grass (Min 200M ²)	M ²	M ²		
10	Hoeing (6Mt radius around buildings)	M ²	M ²		
			SUB TOTAL		
			ADD 14% VAT		
			TOTAL TENDER PRICE		

.....
Respondent's Signature

.....
Date & Company Stamp

SECTION 6**RFP NUMBER****FOR THE AS AND WHEN CONTROL OF VEGETATION INCLUDING TREES, BUSH
AND CUTTING OF GRASS IN THE BLOEMFONTEIN REGION****FOR A PERIOD OF 24 Months****Safety Arrangements – Act 85 of 1993 and Regulations E4E****SAFETY ARRANGEMENTS AND PROCEDURAL COMPLIANCE****WITH THE OCCUPATIONAL HEALTH AND SAFETY ACT
(ACT 85 OF 1993) AND APPLICABLE REGULATIONS****1. General**

- 1.1 The Contractor and Transnet Limited (hereinafter referred to as "Transnet") are individual employers, each in its own right, with their respective duties and obligations set out in the Occupational Health and Safety Act, Act 85 of 1993 (the Act) and applicable Regulations.
- 1.2 The Contractor accepts, in terms of the General Conditions of Contract and in terms of the Act, his obligations as an employer in respect of all persons in his employ, other persons on the premises or the Site or place of work or on the work to be executed by him, and under his control. He shall, before commencement with the execution of the contract work, comply with the provisions set out in the Act, and shall implement and maintain a Health and Safety Plan as described in the Construction Regulations, 2003 and as approved by Transnet, on the Site and place of work for the duration of the Contract.
- 1.3 The Contractor accepts his obligation to complying fully with the Act and applicable Regulations notwithstanding the omission of some of the provisions of the Act and the Regulations from this document.
- 1.4 Transnet accepts, in terms of the Act, its obligations as an employer of its own employees working on or associated with the site or place of work, and the Contractor and Technical Officer or his deputy shall at all times, co-operate in respect of the health and safety management of the site, and shall agree on the practical arrangements and procedures to be implemented and maintained during execution of the Works.
- 1.5 In the event of any discrepancies between any legislation and this specification, the applicable legislation will take precedence.

2. Definitions

- 2.1 In this Specification any word or expression to which a meaning has been assigned in the Construction Regulations, shall have the meaning so assigned to it, unless the context otherwise indicates: -
- 2.2 The work included in this Contract shall for the purposes of compliance with the Act be deemed to be "**Construction Work**", which, in terms of the Construction Regulations, 2003 means any work in connection with: -
- (a) the erection, maintenance, alteration, renovation, repair, demolition or dismantling of or addition to a building or any similar structure;
 - (b) the installation, erection, dismantling or maintenance of fixed plant where such work includes the risk of a person falling;
 - (c) the construction, maintenance, demolition or dismantling of any bridge, dam, canal, road, railway, runway, sewer or water reticulation system or any similar civil engineering structure; or
 - (d) the moving of earth, clearing of land, the making of an excavation, piling, or any similar type of work;
- 2.3 "**competent person**" in relation to construction work, means any person having the knowledge, training and experience specific to the work or task being performed: Provided that where appropriate qualifications and training are registered as per the South African Qualifications Authority Act, 1995 these qualifications and training shall be deemed to be the required qualifications and training;
- 2.4 "**contractor**" means principal contractor and "subcontractor" means contractor as defined by the Construction Regulations, 2003.
- 2.5 "**fall protection plan**" means a documented plan, of all risks relating to working from an elevated position, considering the nature of work undertaken, and setting out the procedures and methods applied to eliminate the risk;
- 2.6 "**health and safety file**" means a file, or other record in permanent form, containing the information required to be kept on site in accordance with the Act and applicable Regulations;
- 2.7 "**Health and Safety Plan** " means a documented plan which addresses the hazards identified and include safe work procedures to mitigate, reduce or control the hazards identified;
- 2.8 "**Risk Assessment**" means a programme to determine any risk associated with any hazard at a construction site, in order to identify the steps needed to be taken to remove, reduce or control such hazard;
- 2.9 "**the Act**" means the Occupational Health and Safety Act No. 85 of 1993.

3. Procedural Compliance

- 3.1 The Contractor who intends to carry out any construction work shall, before carrying out such work, notify the Provincial Director in writing if the construction work:-

includes the demolition of a structure exceeding a height of 3 meters; or

includes the use of explosives to perform construction work; or

- (c) includes the dismantling of fixed plant at a height greater than 3m, and shall also notify the Provincial Director in writing when the construction work exceeds 30 days or will involve more than 300 person days of construction work and if the construction work:-
- (d) includes excavation work deeper than 1m; or
- (e) Includes working at a height greater than 3 meters above ground or a landing.

The notification to the Provincial Director shall be on a form similar to Annexure A of the Construction Regulations, 2003, also shown in Annexure 1 of this Specification. The Contractor shall ensure that a copy of the completed notification form is kept on site for inspection by an inspector, Technical Officer or employee.

The Contractor shall, in accordance with the Act and applicable Regulations, make all the necessary appointments of competent persons in writing on a form similar to Annexure 2 of this Specification and deliver copies thereof to the Technical Officer. Copies should also be retained on the health and safety file.

Subcontractors shall also make the above written appointments and the Contractor shall deliver copies thereof to the Technical Officer.

In the case of a self-employed Contractor or any subcontractor who has the appropriate competencies and supervises the work himself, the appointment of a construction supervisor in terms of regulation 6.1 of the Construction Regulations, 2003 will not be necessary. The Contractor shall in such a case execute and sign a declaration, as in Annexure 3, by which he personally undertakes the duties and obligations of the "Chief Executive Officer" in terms of section 16(1) of the Act.

The Contractor shall, before commencing any work, obtain from the Technical Officer an access certificate as in Annexure 4 executed and signed by him, permitting and limiting access to the designated site or place of work by the Contractor and any subcontractors under his control.

Procedural compliance with Act and Regulations, as above, shall also apply to any subcontractors as employers in their own right. The Contractor shall furnish the Technical Officer with full particulars of such subcontractors and shall ensure that they comply with the Act and Regulations and Protekon's safety requirements and procedures.

4. Special Permits

Where special permits are required before work may be carried out such as for hot work, isolation permits, work permits and occupations, the Contractor shall apply to the Technical Officer or the relevant authority for such permits to be issued. The Contractor shall strictly comply with the conditions and requirements pertaining to the issue of such permits.

5. Health and Safety Programme

- 5.1 The Tenderer shall, with his tender, submit a Health and Safety Programme setting out the practical arrangements and procedures to be implemented by him to ensure compliance by him with the Act and Regulations and particularly in respect of: -

- (i) The provision, as far as is reasonably practical, of a working environment that is safe and without risk to the health of his employees and subcontractors in terms of section 8 of the Act;
 - (ii) the execution of the contract work in such a manner as to ensure in terms of section 9 of the Act that persons other than those in the Contractor's employment, who may be directly affected by the contract work are not thereby exposed to hazards to their health and safety;
 - (iii) ensuring, as far as is reasonably practical, in terms of section 37 of the Act that no employee or subcontractor of the Contractor does or omits to do any act which would be an offence for the Contractor to do or omit to do.
- 5.2 The Contractor's Health and Safety Programme shall be based on a risk assessment in respect of the hazards to health and safety of his employees and other persons under his control that are associated with or directly affected by the Contractor's activities in performing the contract work and shall establish precautionary measures as are reasonable and practical in protecting the safety and health of such employees and persons.
- 5.3 The Contractor shall cause a risk assessment contemplated in clause 5.2 above to be performed by a competent person, appointed in writing, before commencement of any Construction Work and reviewed during construction. The Risk Assessments shall form part of the Health and Safety programme to be applied on the site and shall include at least the following:
- (a) The identification of the risks and hazards that persons may be exposed to;
 - (b) the analysis and evaluation of the hazards identified;
 - (c) a documented Health and Safety Plan, including safe work procedures to mitigate, reduce or control the risks identified;
 - (d) a monitoring and review plan.
- 5.4 The Health and Safety Plan shall include full particulars in respect of: -
- (a) The safety management structure to be instituted on site or place of work and the names of the Contractor's health and safety representatives and members of safety committees where applicable;
 - (b) the safe working methods and procedures to be implemented to ensure the work is performed in compliance with the Act and Regulations;
 - (c) the safety equipment, devices and clothing to be made available by the Contractor to his employees;
 - (d) the site access control measures pertaining to health and safety to be implemented;
 - (e) the arrangements in respect of communication of health and safety related matters and incidents between the Contractor, his employees, subcontractors and the Technical Officer with particular reference to the reporting of incidents in compliance with Section 24 and General Administrative Regulation 8 of the Act and with the pertinent clause of the General Conditions of Contract forming part of the Contract and
 - (f) the introduction of control measures for ensuring that the Safety Plan is maintained and monitored for the duration of the Contract.

- 5.4 The Health and Safety programme shall be subject to the Technical Officer's approval and he may, in consultation with the Contractor, order that additional and/or supplementary practical arrangements and procedures be implemented and maintained by the Contractor or that different working methods or safety equipment be used or safety clothes be issued which, in the Technical Officer's opinion, are necessary to ensure full compliance by the Contractor with his obligations as an employer in terms of the Act and Regulations. The Technical Officer or his deputy shall be allowed to attend meetings of the Contractor's safety committee as an observer.
- 5.5 The Contractor shall take reasonable steps to ensure that each subcontractor's Health and Safety Plan is implemented and maintained on the construction site: Provided that the steps taken shall include periodic audits at intervals mutually agreed to between them, but at least once every month.
- 5.6 The Contractor shall stop any subcontractor from executing any construction work, which is not in accordance with the Contractor's, and/or subcontractor's Health and Safety Plan for the site or which poses a threat to the health and safety of persons.
- 5.7 The Contractor shall ensure that a copy of the Health and Safety Plan is available on site for inspection by an inspector, Technical Officer, agent, subcontractor, employee, registered employee organization, health and safety representative or any member of the health and safety committee.
- 5.8 The Contractor shall consult with the health and safety committee or, if no health and safety committee exists, with a representative group of employees, on the development, monitoring and review of the Risk Assessment.
- 5.9 The Contractor shall ensure that all employees under his control are informed, instructed and trained by a competent person regarding any hazard and the related work procedures before any work commences, and thereafter at such times as may be determined in the Risk Assessment.
- 5.10 The Contractor shall ensure that all subcontractors are informed regarding any hazard as stipulated in the Risk Assessment before any work commences, and thereafter at such times as may be determined in the Risk Assessment.
- 5.11 The Contractor shall ensure that all visitors to a construction site undergoes health and safety induction pertaining to the hazards prevalent on the site and shall be provided with the necessary personal protective equipment.

6. Fall Protection Plan

- 6.1 In the event of the risk and hazard identification, as required in terms of clause 5.3 of this Specification, revealing risks relating to working from an elevated position the contractor shall cause the designation of a competent person, responsible for the preparation of a fall protection plan;
- 6.2 The Contractor shall implement, maintain and monitor the fall protection plan for the duration of Contract. The Contractor shall also take such steps to ensure the continued adherence to the fall protection plan.

6.3 The fall protection plan shall include:-

- (a) A Risk Assessment of all work carried out from an elevated position;
- (b) the procedures and methods to address all the identified risks per location;
- (c) the evaluation of the employees physical and psychological fitness necessary to work at elevated positions;
- (d) the training of employees working from elevated positions; and
- (e) the procedure addressing the inspection, testing and maintenance of all fall protection equipment.

7. Hazards and Potential Hazardous Situations

The Contractor and the Technical Officer shall immediately notify one another of any hazardous or potentially hazardous situations which may arise during performance of the Contract by the Contractor or any subcontractor and, in particular, of such hazards as may be caused by the design, execution and/or location and any other aspect pertaining to the contract work.

8. Health and Safety File

- 8.1 The Contractor shall ensure that a health and safety file is opened and kept on site and shall include all documentation required as per the Act and applicable regulations, and made available to an inspector, the Technical Officer, or subcontractor upon request.
- 8.2 The Contractor shall ensure that a copy of the both his Health and Safety Plan as well as any subcontractor's Health and Safety Plan is available on request to an employee, inspector, contractor or the Technical Officer.
- 8.3 The Contractor shall hand over a consolidated health and safety file to the Technical Officer upon completion of the Construction Work and shall in addition to documentation mentioned in the Act and applicable Regulations include a record of all drawings, designs, materials used and other similar information concerning the completed structure.

CONTRACTORS "HEALTH & SAFETY FILE" CHECKLIST**FOR THE AS AND WHEN CONTROL OF VEGETATION INCLUDING TREES,
BUSH AND CUTTING OF GRASS IN THE BLOEMFONTEIN REGION**

Contractor's Name:

Contract
Number: _____**CONTENTS OF THE HEALTH & SAFETY FILE**

The safety file shall at least contain "but not limited to" the following documentation/copies on site.

		YES	NO
1.	Notice of construction work to Dept. of Labour (where applicable) .		
2.	Letter of good standing – Compensation.		
3.	Section 37(2) agreements. (Written defined responsibilities by mandatories)		
4.	Safety plan "which shall contain": - Appointments letters i.e. copies. - Applicable Written Safe Work Procedures (WSWP's) and Job Observations (J O's). - Fall protection plan (where applicable).		
5.	Your Health and Safety structure on site . - i.e. Organogram "also depicting sub-contractors on site (In the event of large contracts).		
6.	Appointments letters i.e. copies. - Safety Reps (E4E). (Health and Safety structure for large contracts) . - Sub-contractors.		
7.	Emergency equipment and procedures e.g. First Aid box, Fire Extinguishers, tele nos. etc.		
8.	Competency certificates "i.e. copies" . - "Competent persons" as required by the Regulations (Construction Regs.). - Machine operators (Large & Small plant) . - Lifting Equipment operators.		
9.	Health and Safety induction records.		
10.	Copies of medical surveillance records. - Fitness certificates "e.g. working at heights.		
11.	Inspect Plant and Equipment (Includes all electrical equipment) and checklist.		
12.	Test certificates (e.g. Gases, Vapours etc. in confined spaces) .		
13.	Minutes of safety meetings held on site.		
14.	Daily Safety talks by Contractor, etc, including attendance register (Green Areas etc.)		

Respondent's Signature

Date & Company Stamp

15.	Copies of hazardous waste removal and disposal certificates.		
16.	Copies of audit reports. (Contractor's & Spoornet)		
17.	Copies of site inspections. (Contractor's) (Initial and daily)		
18.	Incident investigation records.		
19.	Permits / occupation certificates		
20.	Notices served by Dept. of Labour.		
21.			
22.			
23.			

* If the response to any of the above questions was negative, what actions were taken to rectify it?

Technical Officer of Contract

Site Supervisor

PREVIEW COPY ONLY

.....
Respondent's Signature

.....
Date & Company Stamp

SECTION 7

RFP NUMBER

**FOR THE AS AND WHEN CONTROL OF VEGETATION INCLUDING TREES, BUSH
AND CUTTING OF GRASS IN THE BLOEMFONTEIN REGION**

FOR A PERIOD OF 24 Months

Railway Lines and High Voltage Equipment E7/1

E7/1 (July 1998)

**SPECIFICATION FOR WORKS ON, OVER, UNDER OR ADJACENT TO RAILWAY LINES AND
NEAR HIGH VOLTAGE EQUIPMENT**

(This Specification shall be used in Transnet Contracts)

CONTENTS

<u>CLAUSE</u>	<u>DESCRIPTION</u>
1.	<u>DEFINITIONS</u>
	<u>PART A - GENERAL SPECIFICATION</u>
2.	Authority of officers of Transnet
3.	Contractor's representatives
4.	Occupations and work permits
5.	Speed restrictions and protection
6.	Roads on Transnet property
7.	Clearances
8.	Stacking of material
9.	Excavation, shoring, dewatering and drainage
10.	False work for structures
11.	Piling
12.	Underground services
13.	Blasting
14.	Rail trolleys
15.	Signal track circuits
16.	Penalty for delays to trains
	<u>PART B - ADDITIONAL SPECIFICATION FOR WORK NEAR HIGH-VOLTAGE ELECTRICAL EQUIPMENT</u>
17.	General
18.	Work on buildings of fixed structures
19.	Work done on or outside of rolling stock, including loading and unloading
20.	Use of equipment
21.	Carrying and handling material and equipment
22.	Precautions to be taken when erecting or removing poles, antennae and trees
23.	Use of water
24.	Use of construction plant
25.	Work performed under dead conditions under cover

- of a work permit
26. Traction return circuits in rails
 27. Blasting
 28. High-voltage electrical equipment not maintained and/or operated by Transnet

ANNEXES

1. Horizontal clearances 1 065 mm gauge
2. Vertical clearances 1 065 mm gauge
3. Clearances 610 mm gauge
4. Platform clearances

1 DEFINITIONS

The following definitions shall apply :

Authorised Person. A person whether an employee of Transnet or not, who has been specially authorised to undertake specific duties in terms of Transnet's publication SAFETY INSTRUCTIONS: HIGH-VOLTAGE ELECTRICAL EQUIPMENT, and who holds a certificate or letter of authority to that effect.

Barrier. Any device designed to restrict access to "live" high-voltage electrical equipment.

Bond. A short conductor installed to provide electrical continuity.

Contractor. Any person or organisation appointed by Transnet to carry out work on its behalf.

Dead. Isolated and earthed.

Electrical Officer (Contracts). The person appointed in writing by the responsible Electrical Engineer in Transnet as the person who shall be consulted by the Contractor in all electrical matters to ensure that adequate safety precautions are taken by the Contractor.

Executive Officer. The person appointed by Transnet from time to time as the Executive Officer to act according to the rights and powers held by and obligations placed upon him in terms of the Contract.

High-Voltage. A voltage normally exceeding 1 000 volts.

Live. A conductor is said to be "live" when it is at a potential different from that of the earth or any other conductor of the system of which it forms a part.

Near. To be in such a position that a person's body or the tools he is using or any equipment he is handling may come within 3 metres of live exposed high-voltage electrical equipment.

Occupation. An authorisation granted by Transnet for work to be carried out under specified conditions on, over under or adjacent to railway lines.

Occupation Between Trains. An occupation during an interval between successive trains.

Project Manager. The person or juristic person appointed by Transnet from time to time as the Project Manager, to administer the Contract according to the powers and rights held by and obligations placed upon him in terms of the Contract.

Responsible Representative. The responsible person in charge, appointed by a contractor, who has undergone specific training (and holds a certificate) to supervise staff under his control to work on, over, under or adjacent to railway lines and in the vicinity of high-voltage electrical equipment.

Technical Officer. The person or juristic person appointed by Transnet from time to time as the Technical Officer, to administer the Contractor's performance and execution of the Works according to the powers and rights held by and obligations placed upon the Technical Officer in terms of the Contract.

Total Occupation. An occupation for a period when trains are not to traverse the section of line covered by the occupation.

Work on. Work undertaken on or so close to the equipment that the specified working clearances to the live equipment cannot be maintained.

Work Permit. A combined written application and authority to proceed with work on or near dead electrical equipment.

PART A - GENERAL SPECIFICATION

2. AUTHORITY OF OFFICERS OF TRANSNET

- 2.1 The Contractor shall co-operate with the officers of Transnet and shall comply with all instructions issued and restrictions imposed with respect to the Works which bear on the existence and operation of Transnet's railway lines and high-voltage equipment.
- 2.2 Without limiting the generality of the provisions of 2.1, any duly authorised representative of Transnet, having identified himself, may stop the work if, in his opinion, the safe passage of

trains or the safety of Transnet assets or any person is affected. **CONSIDERATIONS OF SAFETY SHALL TAKE PRECEDENCE OVER ALL OTHER CONSIDERATIONS.**

3. **CONTRACTOR'S REPRESENTATIVES**

- 3.1 The Contractor shall nominate Responsible Representatives of whom at least one shall be available at any hour for call-out in cases of emergency. The Contractor shall provide the Technical Officer with the names, addresses and telephone numbers of the representatives.
- 3.2 The Contractor guarantees that he has satisfied himself that the Responsible Representative is fully conversant with this specification and that he shall comply with all his obligations in respect thereof.

4. **OCCUPATIONS AND WORK PERMITS**

- 4.1 Work to be done during total occupation or during an occupation between trains or under a work permit shall be done in a manner decided by the Technical Officer and at times to suit Transnet requirements.
- 4.2 The Contractor shall organise the Works in a manner, which will minimise the number and duration of occupations and work permits required.
- 4.3 Transnet will not be liable for any financial or other loss suffered by the Contractor arising from his failure to complete any work scheduled during the period of an occupation or work permit.
- 4.4 The Contractor shall submit to the Technical Officer, in writing, requests for occupations or work permits together with details of the work to be undertaken, at least 14 days before they are required. Transnet does not undertake to grant an occupation or work permit for any particular date, time or duration.
- 4.5 Transnet reserves the right to cancel any occupation or work permit at any time before or during the period of occupation or work permit. If, due to cancellation or change in date or time, the Contractor is not permitted to start work under conditions of total occupation or work permit at the time arranged, all costs caused by the cancellation shall be borne by the Contractor except as provided for in clauses 4.6 to 4.8.

- 4.6 When the Contractor is notified less than 2 hours before the scheduled starting time that the occupation or work permit is cancelled, he may claim reimbursement of his direct financial losses caused by the loss of working time up to the time his labour and plant are employed on other work, but not exceeding the period of the cancelled occupation or work permit.
- 4.7 When the Contractor is notified less than 2 hours before the schedule starting time, or during an occupation or work permit, that the duration of the occupation or work permit is reduced, he may claim reimbursement of his direct financial losses caused by the loss of working time due to the reduced duration of the occupation or work permit.
- 4.8 Reimbursement the Contractor for any loss of working time in terms of 4.6 and 4.7, shall be subject to his claims being submitted within 14 days of the event with full details of labour and plant involved, and provided that the Technical Officer certifies that no other work on which the labour and plant could be employed was immediately available.
- 4.9 Before starting any work for which an occupation has been arranged, the Contractor shall obtain from the Technical Officer written confirmation of the date, time and duration of the occupation.
- 4.10 Before starting any work for which a work permit has been arranged, the Responsible Representative shall read and sign portion C of form No. T.1276 signifying that he is aware of the limits within which work may be undertaken. After the work for which the permit was granted has been completed, or when the work permit is due to be terminated, or if the permit is cancelled after the start, the same person who signed portion C shall sign portion D of the T.1276 form, thereby acknowledging that he is aware that the electrical equipment is to be made "live". The Contractor shall advise all his workmen accordingly.

5. SPEED RESTRICTIONS AND PROTECTION

- 5.1 When speed restrictions are imposed by Transnet because of the Contractor's activities, the Contractor shall organise and carry out his work so as to permit the removal of the restrictions as soon as possible.
- 5.2 When the Technical Officer considers protection to be necessary the Contractor shall, unless otherwise agreed, provide all protection including flagmen, other personnel and all equipment for the protection of Transnet's and the Contractor's personnel and assets, the public and including trains. Transnet will provide training free of charge of the Contractor's flagmen and other personnel performing protection duties. The Contractor shall consult with the Technical Officer, whenever he considers that protection will be necessary, taking into account the minimum permissible clearances set out in appendixes 1 to 4.

- 5.3 The Contractor shall appoint a Responsible Representative to receive and transmit any instruction, which may be given by Transnet personnel providing protection.

6. **ROADS ON TRANSNET PROPERTY**

The provision of clause 25 of the E.5, General Conditions of Contract, or clause 23 of the E.5 (MW), General Conditions of Contract for Maintenance Works, shall apply to the use of existing roads on Transnet's property.

7. **CLEARANCES**

- 7.1 No temporary works shall encroach on the appropriate minimum clearances set out in Annexure 1 BE97-01 Sheets 1,2, 3 and 5 of 5.

8. **STACKING OF MATERIAL**

- 8.1 The Contractor shall not stack any material closer than 3 m from the centre line of any railway line without prior approval of the Technical Officer.

9. **EXCAVATION, SHORING, DEWATERING AND DRAINAGE**

- 9.1 Unless otherwise approved by the Technical Officer any excavation adjacent to a railway line shall not encroach on the hatched area shown in Figure 1.

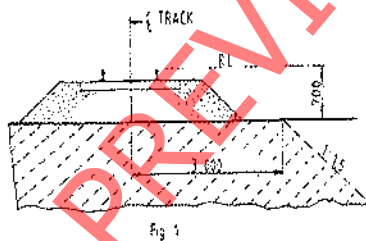

- 9.2 The Contractor shall provide at his own cost any shoring, dewatering or drainage of any excavation unless otherwise stipulated elsewhere in the Contract.
- 9.3 Where required by the Technical Officer, drawings of shoring for any excavation under or adjacent to a railway line shall be submitted and permission to proceed obtained, before the excavation is commenced.

9.4 The Contractor shall prevent ingress of water to the excavation but where water does enter, he shall dispose of it as directed by the Technical Officer.

9.5 The Contractor shall not block, obstruct or damage any existing drains either above or below ground level unless he has made adequate prior arrangements to deal with drainage.

10. **FALSEWORK FOR STRUCTURES**

10.1 Drawings of false work for the construction of any structure over, under or adjacent to any railway line shall be submitted to the Technical Officer and his permission to proceed obtained before the false work is erected. Each drawing shall be given a title and a distinguishing number and shall be signed by a registered professional engineer certifying that he has checked the design of the false work and that the drawings are correct and in accordance with the design.

10.2 After the false work has been erected and before any load is applied, the Contractor shall submit to the Technical Officer a certificate signed by a registered professional engineer certifying that he has checked the false work and that it has been erected in accordance with the drawings. Titles and numbers of the drawings shall be stated in the certificate. Notwithstanding permission given by the Technical Officer to proceed, the Contractor shall be entirely responsible for the safety and adequacy of the false work.

11. **PILING**

11.1 The Technical Officer will specify the conditions under which piles may be installed on Transnet property.

12. **UNDERGROUND SERVICES**

12.1 No pegs or stakes shall be driven or any excavation made before the Contractor has established that there are no underground services, which may be damaged thereby.

12.2 Any damage shall be reported immediately to the Technical Officer, or to the official in charge at the nearest station, or to the traffic controller in the case of centralised traffic control.

13. **BLASTING**

- 13.1 The provisions of clause 23 of the E.5, General Conditions of Contract or clause 21 of the E.5 (MW), General Conditions of Contract for Maintenance Work, shall apply to all blasting operations undertaken in terms of the Contract.
- 13.2 The Contractor shall provide proof that he has complied with the provisions of clauses 10.17.1 to 10.17.4 of the Explosives Regulations (Act 26 of 1956 as amended).
- 13.3 Blasting within 500m of a railway line will only be permitted during intervals between trains. A person appointed by the Technical Officer, assisted by flagmen with the necessary protective equipment, will be in communication with the controlling railway station. Only this person will be authorised to give the Contractor permission to blast, and the Contractor shall obey his instructions implicitly regarding the time during which blasting may take place.
- 13.4 The flagmen described in 13.3, where provided by Transnet, are for the protection of trains and Transnet property only, and their presence does not relieve the Contractor in any manner of his responsibilities in terms of Explosives Act or Regulations, or any obligation in terms of this Contract.
- 13.5 The person described in 13.3 will record in a book provided and retained by Transnet the dates and times -
- (i) When each request is made by him to the controlling station for permission to blast;
 - (ii) When blasting may take place;
 - (iii) When blasting actually takes place; and
 - (iv) When he advises the controlling station that the line is safe for the passage of trains.
- 13.6 Before each blast the Contractor shall record in the same book, the details of the blast to be carried out. The person appointed by the Technical Officer and the person who will do the blasting shall both sign the book whenever an entry described in 13.5 is made.
- 13.7 The terms of clause 27 hereof shall be strictly adhered to.

14. RAIL TROLLEYS

- 14.1 The use of rail trolleys or trestle trolleys on a railway line for working on high voltage equipment will be permitted only if approved by the Technical Officer and under the conditions stipulated by him.
- 14.2 All costs in connection with such trolley working requested by the Contractor shall, unless otherwise agreed, be borne by the Contractor, excluding the costs of any train protection services normally provided free of charge by Transnet.

15. **SIGNAL TRACK CIRCUITS**

- 15.1 Where signal track circuits are installed, the Contractor shall ensure that no material capable of conducting an electrical current makes contact between rails of a railway line/lines.
- 15.2 No signal connections on track-circuited tracks shall be severed without the Technical Officer's knowledge and consent.

16. **PENALTY FOR DELAYS TO TRAINS**

- 16.1 If any trains are delayed by the Contractor and the Technical Officer is satisfied that the delay was avoidable, a penalty will be imposed on the Contractor of R5 000 per hour or part thereof for the period of delay, irrespective of the number of trains delayed.

PART B - ADDITIONAL SPECIFICATION FOR WORK NEAR HIGH-VOLTAGE ELECTRICAL EQUIPMENT

17. **GENERAL**

- 17.1 This specification is based on the contents of Transnet's publication SAFETY INSTRUCTIONS, HIGH-VOLTAGE ELECTRICAL EQUIPMENT, as amended, a copy of which will be made available on loan to the Contractor for the duration of the contract. These instructions apply to all work near live high-voltage equipment maintained and/or operated by Transnet, and the onus rests on the Contractor to ensure that he obtains a copy.
- 17.2 The Contractor's attention is drawn in particular to the contents of Part I, Sections 1 and 2 of the Safety Instructions: High-Voltage Electrical Equipment.
- 17.3 The Safety Instructions : High-Voltage Electrical Equipment cover the minimum safety precautions which must be taken to ensure safe working on or near high-voltage electrical equipment, and must be observed at all times. Should additional safety measures be considered necessary because of peculiar local conditions, these may be ordered by and at the discretion of the Electrical Officer (Contracts).
- 17.4 This specification must be read in conjunction with and not in lieu of the Safety Instructions : High-Voltage Electrical Equipment.
- 17.5 The Contractor shall obtain the approval of the Electrical Officer (Contracts) before any work is done which causes or could cause any portion of a person's body or the tools he is using

or any equipment he is handling, to come within 3 metres of any live high-voltage equipment.

17.6 The Contractor shall regard all high-voltage equipment as live unless a work permit is in force.

17.7 Safety precautions taken or barriers erected shall comply with the requirements of the Electrical Officer (Contracts), and shall be approved by him before the work to be protected is undertaken by the Contractor. The Contractor shall, unless otherwise agreed, bear the cost of the provision of the barriers and other safety precautions required, including the attendance of Transnet staff where this is necessary.

17.8 No barrier shall be removed unless authorised by the Electrical Officer (Contracts).

18. **WORK ON BUILDINGS OR FIXED STRUCTURES**

Before any work is carried out or measurements are taken on any part of a building, fixed structure or earthworks of any kind above ground level situated within 3 metres of live high-voltage equipment, the Electrical Officer (Contracts) shall be consulted to ascertain the conditions under which the work may be carried out.

18.2 No barrier erected to comply with the requirements of the Electrical Officer (Contracts) shall be used as temporary staging or shuttering for any part of the Works.

18.3 The shuttering for bridge piers, abutments, retaining walls or parapets adjacent to or over any track may be permitted to serve as a barrier, provided that it extends at least 2,5 metres above any working level in the case of piers, abutments and retaining walls and 1,5 metres above any working level in the case of parapets.

19. **WORK DONE ON OR OUTSIDE OF ROLLING STOCK, INCLUDING LOADING OR UNLOADING**

19.1 No person shall stand, climb or work whilst on any platform, surface or foothold higher than the normal unrestricted places of access, namely -

- (i) the floor level of trucks;
- (ii) external walkways on diesel, steam and electric locomotives, steam heat vans, etc.
and
- (iii) walkways between coaches and locomotives.

When in these positions, no person may raise his hands or any equipment or material he is handling above his head.

- 19.2 In cases where the Contractor operates his own rail mounted equipment, he shall arrange for the walkways on this plant to be inspected by the Electrical Officer (Contracts) and approved, before commencement of work.
- 19.3 The handling of long lengths of material such as metal pipes, reinforcing bars, etc should be avoided, but if essential they shall be handled as nearly as possible in a horizontal position below head height.
- 19.4 The Responsible Representative shall warn all persons under his control of the danger of being near live high-voltage equipment, and shall ensure that the warning is fully understood.
- 19.5 Where the conditions in 19.1 to 19.3 cannot be observed the Electrical Officer (Contracts), shall be notified. He will arrange for suitable Safety measures to be taken. The Electrical Officer (Contracts), may in his discretion and in appropriate circumstances, arrange for a suitable employee of the Contractor to be specially trained by Transnet and at its costs, as an Authorised Person to work closer than 3 metres from live overhead conductors and under such conditions as may be imposed by the Senior responsible Electrical Engineer in Transnet.

20. USE OF EQUIPMENT

20.1 Measuring Tapes and Devices

- 20.1.1 Measuring tapes may be used near live high-voltage equipment provided that no part of any tape or a person's body comes within 3 metres of the live equipment.
- 20.1.2 In windy conditions the distance shall be increased to ensure that if the tape should fall it will not be blown nearer than 3 metres from the live high-voltage equipment.
- 20.1.3 Special measuring devices longer than 2 metres such as survey staves and rods may be used if these are of non-conducting material and approved by the responsible Electrical Engineer in Transnet, but these devices must not be used within 3 metres of live high-voltage equipment in rainy or wet conditions.
- 20.1.4 The assistance of the Electrical Officer (Contracts) shall be requested when measurements within the limits defined in 20.1.1 to 20.1.3 are required.

20.1.5 The restrictions described in 20.1.1 to 20.1.3 do not apply on a bridge deck between permanent parapets nor in other situations where a barrier effectively prevents contact with the live high-voltage equipment.

20.2 Portable Ladders

20.2.1 Any type of portable ladder longer than 2 metres may only be used near live high-voltage equipment under the direct supervision of the Responsible Representative. He shall ensure that the ladder is always used in such a manner that the distance from the base of the ladder to any live high-voltage equipment is greater than the fully extended length of the ladder plus 3 metres. Where these conditions cannot be observed, the Electrical Officer (Contracts) shall be advised, and he will arrange for suitable safety measures to be taken.

21. CARRYING AND HANDLING MATERIAL AND EQUIPMENT

21.1 Pipes, scaffolding, iron sheets, reinforcing bars and other material, which exceeds 2 metres in length, shall be carried completely below head height near live high-voltage equipment. For maximum safety two or more persons so as to maintain it as nearly as possible in a horizontal position should carry such material. The utmost care must be taking to ensure that no part of the material comes within 3 metres of any live high-voltage equipment.

21.2 Long lengths of wire or cable shall never be run out in conditions where a part of a wire or cable can come within 3 metres of any live high-voltage equipment unless the Electrical Officer (Contracts) has been advised and has approved appropriate safety precautions.

21.3 The presence of overhead power lines shall always be taken account of especially when communications lines or cables or aerial cables, stay wires, etc. are being erected above ground level.

22. PRECAUTIONS TO BE TAKEN WHEN ERECTING OR REMOVING POLES, ANTENNAE, TREES ETC.

22.1 A pole may be handled for the purpose of erection or removal near high-voltage equipment under the following conditions:

- (i) If the distance between the point at which the pole is to be erected or removed and the nearest live high-voltage equipment is more than the length of the pole plus 3 metres, the work shall be supervised by the Responsible Representative.
- (ii) If the distance described in (i) is less than the length of the pole plus 3 meter's, the Electrical Officer (Contracts) shall be consulted to arrange for an Authorized Person

to supervise the work and to ensure that the pole is earthed where possible. The pole shall be kept in contact with the point of erection, and adequate precautions shall be taken to prevent contact with live high-voltage equipment.

22.2 The cost of supervision by an Authorised Person and the provision of earthing shall, unless otherwise agreed, be borne by the Contractor.

22.3 The provisions of clauses 22.1 and 22.2 shall also apply to the erection or removal of columns, antennae, trees, posts, etc.

23. **USE OF WATER**

23.1 No water shall be used in the form of a jet if it can make contact with any live high-voltage equipment or with any person working on such equipment.

24. **USE OF CONSTRUCTION PLANT**

24.1 "Construction plant" entails all types of plant including cranes, piling frames, boring machines, excavators, draglines, dewatering equipment and road vehicles with or without lifting equipment.

24.2 When work is being undertaken in such a position that it is possible for construction plant or its load to come within 3 metres of live high-voltage equipment, the Electrical Officer (Contracts) shall be consulted. He will arrange for an Authorised Person to supervise the work and to ensure that the plant is adequately earthed. The Electrical Officer (Contracts) will decide whether further safety measures are necessary.

24.3 The cost of any supervision by an Authorised Person and the provision of earthing shall, unless otherwise agreed, be borne by the Contractor.

24.4 When loads are handled by cranes, non-metallic rope hand lines shall be used, affixed to such loads so as to prevent their swinging and coming within 3 metres of live high-voltage equipment.

24.5 Clauses 24.1 to 24.4 shall apply mutatis mutandis to the use of maintenance machines of any nature.

25. **WORK PERFORMED UNDER DEAD CONDITIONS UNDER COVER OF A WORK PERMIT**

- 25.1 If the Responsible Representative finds that the work cannot be done in safety with the high-voltage electrical equipment live, he shall consult the Electrical Officer (Contracts) who will decide on the action to be taken.
- 25.2 If a work permit is issued the Responsible Representative shall -
- (i) before commencement of work ensure that the limits within which work may be carried out have been explained to him by the Authorized Person who issued the permit to him, and that he fully understands these limits.
 - (ii) Sign portion C of the permit before commencement of work;
 - (iii) Explain to all persons under his control the limits within which work may be carried out, and ensure that they fully understand these limits;
 - (iv) Care for the safety of all persons under his control whilst work is in progress; and
 - (v) Withdraw all personnel under his control from the equipment on completion of the work before he signs portion D of the work permit.

26. **TRACTION RETURN CIRCUITS IN RAILS**

- 26.1 DANGEROUS CONDITIONS CAN BE CREATED BY REMOVING OR SEVERING ANY BOND.
- 26.2 Broken rails with an air gap between the ends, and joints, at which fishplates are removed under "broken bond" conditions, are potentially lethal. The rails on either side of an air gap between rail ends on electrified lines shall not be touched simultaneously until rendered safe by Transnet personnel.
- 26.3 The Contractor shall not break any permanent bonds between rails or between rails and any structure. He shall give the Technical Officer at least 7 days written notice when removal of such bonds is necessary.
- 26.4 No work on the track which involves interference with the traction return rail circuit either by cutting or removing the rails, or by removal of bonds shall be done unless the Electrical Officer (Contracts) is consulted. He will take such precautions as may be necessary to ensure continuity of the return circuit before permitting the work to be commenced.

27. **BLASTING**

- 27.1 The Contractor shall obtain the permission of the Electrical Officer (Contracts) before blasting, and shall give at least 14 day's notice of his intention to blast.
- 27.2 No blasting shall be done in the vicinity of electrified lines unless a member of Transnet's electrical personnel is present.

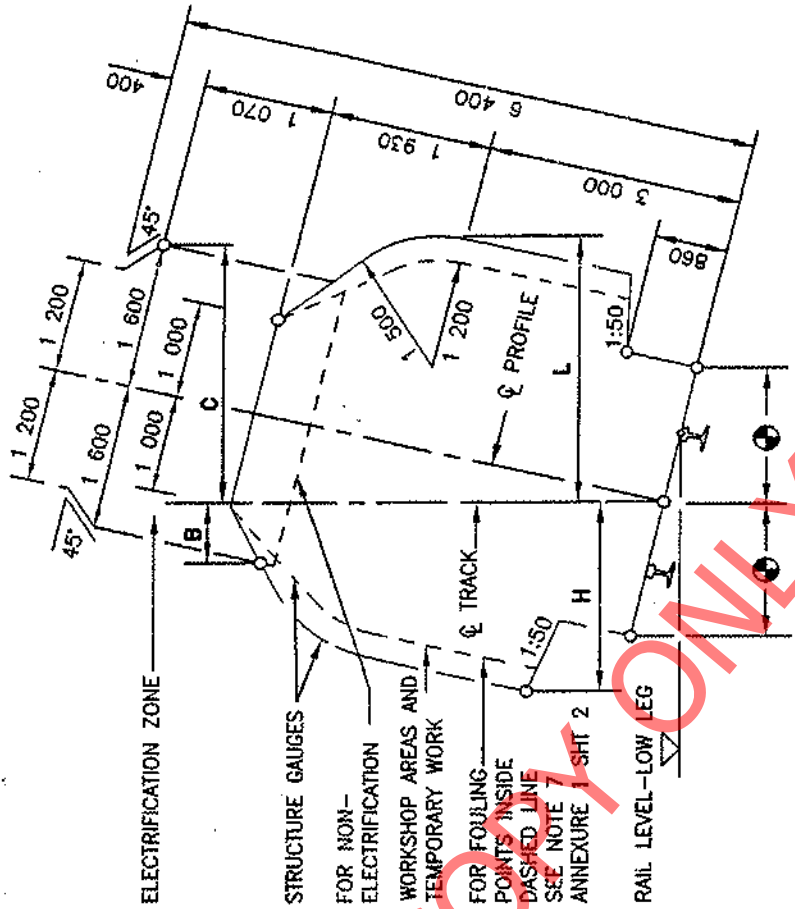

RADIUS (m)	WITH CANT		NO CANT		WITH CANT	
	H (mm)	L (mm)	H & L	B (mm)	C (mm)	
90	2 730	3 090	2 780	1 130	2 100	
100	2 700	3 030	2 750	1 140	2 050	
120	2 650	2 970	2 700	1 160	2 010	
140	2 620	2 920	2 660	1 175	1 990	
170	2 590	2 870	2 630	1 190	1 970	
200	2 570	2 820	2 600	1 205	1 950	
250	2 550	2 790	2 580	1 230	1 920	
300	2 540	2 760	2 560	1 250	1 900	
350	2 530	2 730	2 540	1 270	1 890	
400	2 520	2 710	2 530	1 290	1 875	
500	2 510	2 680	2 520	1 320	1 850	
600	2 500	2 660	2 510	1 340	1 830	
800	2 490	2 620	2 500	1 365	1 790	
1 000	2 480	2 600	2 490	1 380	1 760	
1 200	2 480	2 580	2 490	1 200	1 730	
1 500	2 480	2 550	2 480	1 415	1 700	
2 000	2 480	2 500	2 480	1 440	1 660	
3 000	2 470	2 470	2 470	1 500	1 600	
>5 000	2 460	2 460	2 460	1 600	1 600	

REMARKS:

1. H AND B IS THE REQUIRED HORIZONTAL CLEARANCE ON THE OUTSIDE OF THE CURVE BASED ON MINIMUM CANT.
2. L AND C IS THE REQUIRED HORIZONTAL CLEARANCE ON THE INSIDE OF THE CURVE BASED ON MAXIMUM CANT.
3. INTERMEDIATE VALUES MAY BE INTERPOLATED BY THE ENGINEER IN CHARGE.
4. FOR WORKSHOP AREAS AND TEMPORARY WORK, CLEARANCES H AND L MAY BE REDUCED BY 300mm.
5. SEE ANNEXURE 1 SHEET 3 FOR PLATFORM CLEARANCES.
6. ALSO REFER TO REMARKS 4 TO 8 OF ANNEXURE 1 SHEET 2.

ANNEXURE 1
SHEET 2 of 5
AMENDMENT

VERTICAL CLEARANCES :
1 065mm TRACK GAUGE

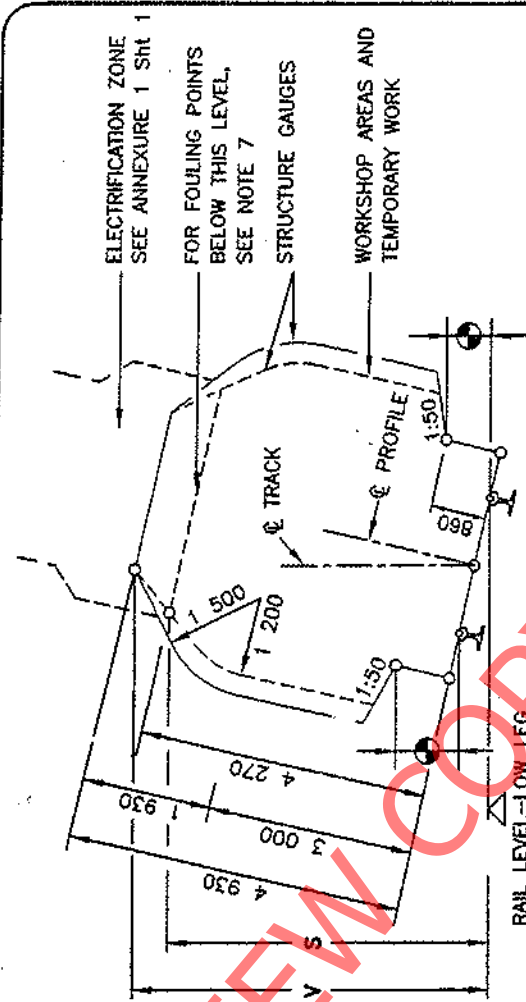

LOCATION	ELECTRIFIED (PRESENT OR FUTURE)	
	NOT ELECTRIFIED	3KV & 25KV 50KV
RADIUS (mm)	S (mm)	V (mm)
100	4 470	5 050
300	4 410	5 020
600	4 370	5 000
1 000	4 350	4 990
1 500	4 310	4 960
2 000	4 290	4 940
>3 000	4 270	4 930
* OVER OR NEAR POINTS AND CROSSING IF REQUIRED BY ELECTRICAL IRRESPECTIVE OF RADIUS		5 650
		6 000

ALL AREAS OTHER THAN
THOSE INDICATED BY
* BELOW

REMARKS:

- V IS THE REQUIRED VERTICAL CLEARANCE EXCEPT WHERE REDUCED CLEARANCE S APPLIES.
- S IS THE MINIMUM VERTICAL CLEARANCE FOR STRUCTURES AND TEMPORARY WORK OVER NON-ELECTRIFIED LINES.
- INTERMEDIATE VALUES MAY BE INTERPOLATED BY THE ENGINEER IN CHARGE.
- FOR APPLICATION AT CURVES
 - APPLY INCREASED CLEARANCES FOR CURVES TO POINTS 3m BEYOND THE ENDS OF THE CIRCULAR CURVE.
 - REDUCE CLEARANCES AT A UNIFORM RATE OVER THE REMAINDER OF THE TRANSITION CURVE.
 - FOR NON-TRANSITIONED CURVES REDUCE AT A UNIFORM RATE OVER A LENGTH OF 15m ALONG STRAIGHTS.
- NEW STRUCTURES: SEE BRIDGE CODE.
- TUNNELS: SEE DRAWING BE 82-35.
- FOULING POINTS: SEE CLAUSE 8.1.
- CLEARANCES ARE BASED ON 15m BOGIE CENTRES AND 21,2m VEHICLE BODY LENGTH.
- SEE ANNEXURE 1 SHEET 3 FOR PLATFORM CLEARANCES.

BE 97-01 Sht 2 of 5 DATE : JUNE 2000

ANNEXURE 1
SHEET 3 of 5
AMENDMENT

CLEARANCES : PLATFORMS

PLATFORMS : TRACK GAUGE 1 065mm

PASSENGERS

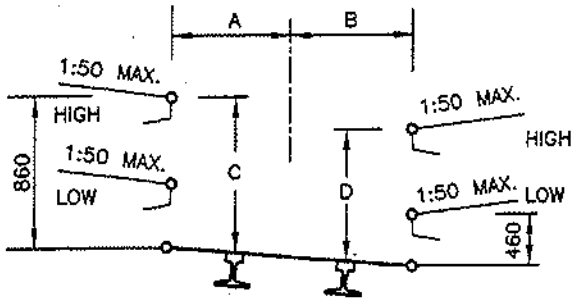

GOODS

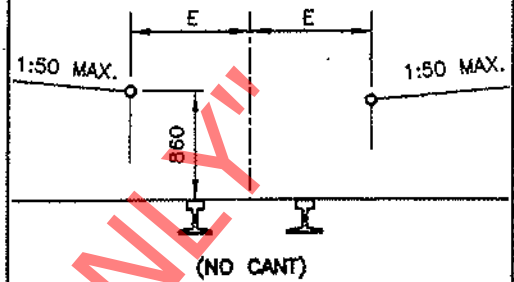

RADIUS (m)	A (mm)	B (mm)	C (mm)	D (mm)	E (mm)
90	1 690	1 820	890	810	1 840
100	1 650	1 790	890	810	1 810
120	1 610	1 740	890	810	1 760
140	1 580	1 700	890	810	1 720
170	1 550	1 660	890	810	1 690
200	1 530	1 630	890	820	1 670
250	1 520	1 600	890	820	1 640
300	1 520	1 580	890	830	1 620
350	1 520	1 560	880	830	1 600
400	1 520	1 550	880	840	1 590
500	1 520	1 540	880	850	1 580
600	1 520	1 530	870	850	1 570
800	1 520	1 520	860	860	1 560
1 200	1 520	1 520	860	860	1 550
2 000	1 520	1 520	860	860	1 540
3 000	1 520	1 520	860	860	1 530
STRAIGHT	1 520	1 520	860	860	1 520

REMARKS:

1. NO CANT TO BE APPLIED EXCEPT WHEN THE GOODS PLATFORM IS ON A RUNNING LINE.
2. INTERMEDIATE VALUES MAY BE INTERPOLATED BY THE ENGINEER IN CHARGE.
3. 8m TO MAIN STATION—BUILDINGS AND 3m TO ALL OTHER STRUCTURES.
4. TOLERANCES : SEE CLAUSE 8.0.10.

STRUCTURES ON PLATFORMS : 1 065mm AND 610mm TRACK GAUGE



BE 97-01 Sht 3 of 5 DATE : JUNE 2000

ANNEXURE 1
SHEET 5 of 5
AMENDMENT

CLEARANCES : 610mm TRACK GAUGE

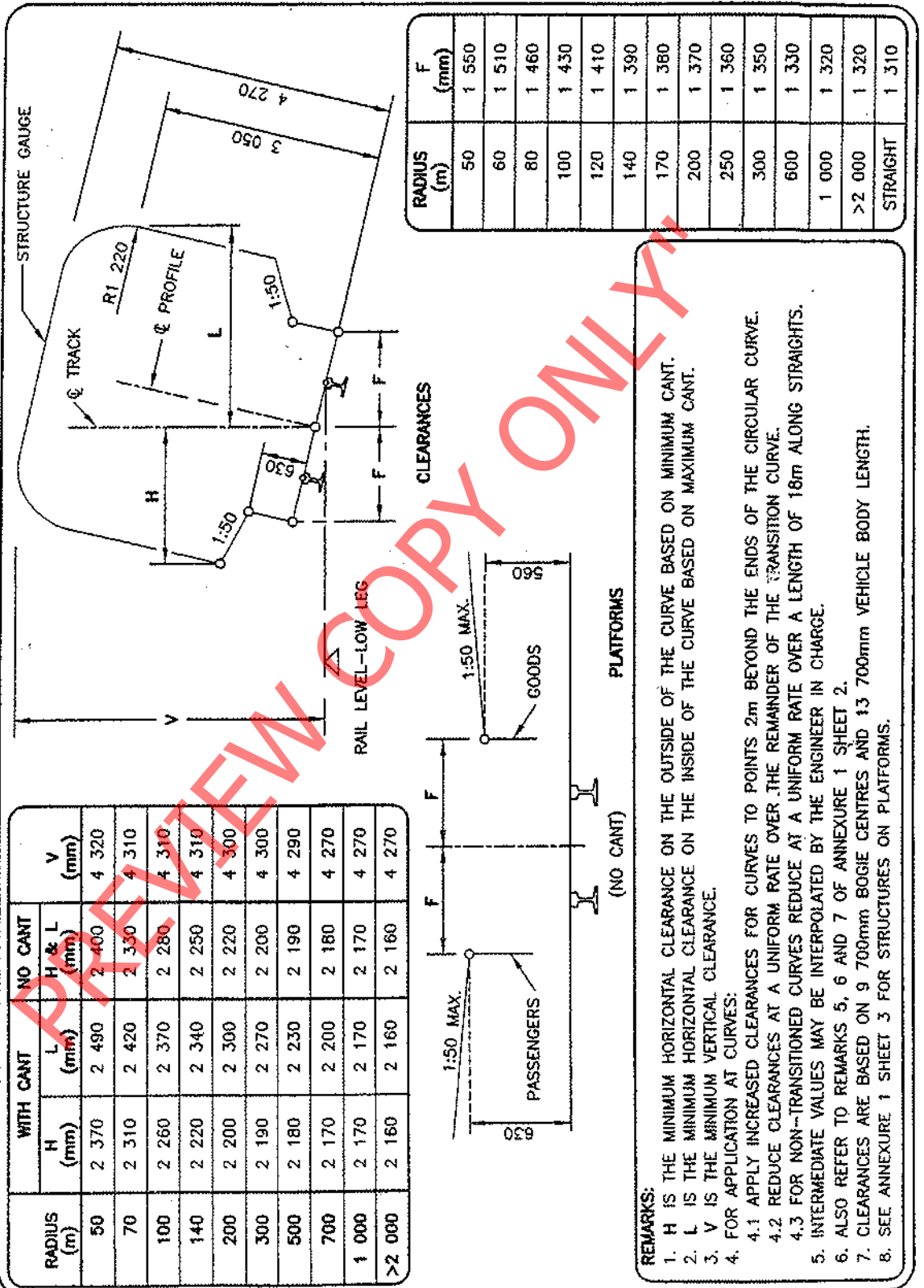

RADIUS (m)	F (mm)
50	1 550
60	1 510
80	1 460
100	1 430
120	1 410
140	1 390
170	1 380
200	1 370
250	1 360
300	1 350
600	1 330
1 000	1 320
>2 000	1 320
STRAIGHT	1 310

RADIUS (m)	WITH CANT		NO CANT		V (mm)
	H (mm)	L (mm)	H & L (mm)	V (mm)	
50	2 370	2 490	2 400	4 320	4 320
70	2 310	2 420	2 330	4 310	4 310
100	2 260	2 370	2 280	4 310	4 310
140	2 220	2 340	2 250	4 310	4 310
200	2 200	2 300	2 220	4 300	4 300
300	2 190	2 270	2 200	4 300	4 300
500	2 180	2 230	2 190	4 290	4 290
700	2 170	2 200	2 180	4 270	4 270
1 000	2 170	2 170	2 170	4 270	4 270
>2 000	2 160	2 160	2 160	4 270	4 270

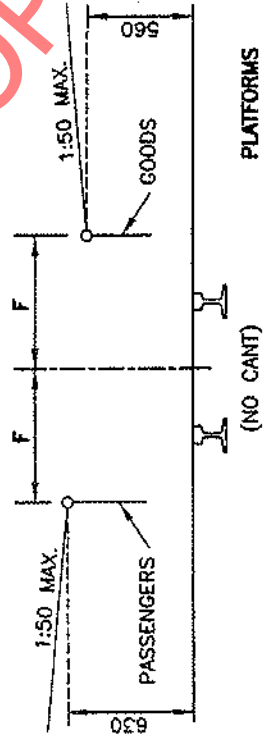

REMARKS:

- H IS THE MINIMUM HORIZONTAL CLEARANCE ON THE OUTSIDE OF THE CURVE BASED ON MINIMUM CANT.
- L IS THE MINIMUM HORIZONTAL CLEARANCE ON THE INSIDE OF THE CURVE BASED ON MAXIMUM CANT.
- V IS THE MINIMUM VERTICAL CLEARANCE.
- FOR APPLICATION AT CURVES:
 - 4.1 APPLY INCREASED CLEARANCES FOR CURVES TO POINTS 2m BEYOND THE ENDS OF THE CIRCULAR CURVE.
 - 4.2 REDUCE CLEARANCES AT A UNIFORM RATE OVER THE REMAINDER OF THE TRANSITION CURVE.
 - 4.3 FOR NON-TRANSITIONED CURVES REDUCE AT A UNIFORM RATE OVER A LENGTH OF 18m ALONG STRAIGHTS.
- INTERMEDIATE VALUES MAY BE INTERPOLATED BY THE ENGINEER IN CHARGE.
- ALSO REFER TO REMARKS 5, 6 AND 7 OF ANNEXURE 1 SHEET 2.
- CLEARANCES ARE BASED ON 9 700mm BOGIE CENTRES AND 13 700mm VEHICLE BODY LENGTH.
- SEE ANNEXURE 1 SHEET 3 FOR STRUCTURES ON PLATFORMS.

BE 97-01 Sht 5 of 5 DATE : JUNE 2000