

Transnet SOC Limited
Transnet RME

REQUEST FOR QUOTATION

TFR RME RFQ Board
TFR RME RFQ Board
Transnet Frieght Rail - RME
PROCUREMENT DEPARTMENT

Registration Number: 1990/000900/06
Vat Number : 4720103177

**Attention:**

Telephone Number :
Fax Number :
Vendor Number :500000

Quotation Deadline Date : 15.11.2013
Quotation Deadline Time : 16:00

REQUEST for QUOTATION

Transnet RME

RFQ Number / Date

6000180864 / 04.11.2013

Contact Person / Telephone

Troy Stevens / 021 940 1892

Return to VAX Number/EMAIL

0218100000 / TCPtendersCapeTown@Transnet.net

Item	Material	Description	RFQ Qty	UoM	Required Del date	Confirm Del date	Unit Price Excl	Total Price Excl
00010		Tie bar 2,75m	30	ea	29.11.2013			

Tie bar 2,75m

Tie bar 2,75m SAR T/C/L galv L=3015mm (TMHB 3)

Contact person Jeff Niemand 0834556385

Project number 1414792

Delivery address: Bellville Square store

Please note these requirements must accompany your response:

We also require a list of qualified welders coded welder's certificates.

Previous project completed in steelwork manufacture and references (3 years experience)

Requester and Delivery Address:



Transnet SOC Limited
 Transnet RME
 TFR RME RFQ Board
 TFR RME RFQ Board
 Transnet Freight Rail - RME
 PROCUREMENT DEPARTMENT
 0000

REQUEST FOR QUOTATION

Registration Number: 1990/000900/06
 Vat Number : 4720103177

Attention:
 Telephone Number :
 Fax Number :
 Vendor Number :500000

Quotation Deadline Date : 15.11.2013
Quotation Deadline Time : 16:00

REQUEST for QUOTATION
 Transnet RME
RFQ Number / Date
 6000180864 / 04.11.2013
Contact Person / Telephone
 Troy Stevens / 021 940 1892
Return to VAX Number/EMAIL
 0218100000 / TCPtendersCapeTown@Transnet.net

Item	Material	Description	RFQ Qty	UoM	Required Del date	Confirm Del date	Unit Price Excl	Total Price Excl
------	----------	-------------	---------	-----	-------------------	------------------	-----------------	------------------

Richard Carswell - Transnet Freight Rail (RME)
 Deliver to Bellville Square Bellville South
 Western Cape

Tel: Richard Carswell 0219401813 & 0834556391
 Cell: Jeff Niemand 0834556385
 Email: richard.carswell@transnet.net
 Fax: 021 9401938

If you are unable to quote for this enquiry, please submit a NO QUOTE, with a short reason, if possible, for not being able to quote.

Otherwise we look forward to receive your quote by the date and time stated.

00020		Backstrap	200	ea	29.11.2013			
-------	--	-----------	-----	----	------------	--	--	--

Backstrap
 Bracket and E/W cleat 280 CRS backstrap GALV (TMFB 168)

Contact person Jeff Niemand 0834556385

Project number 1414792



Transnet SOC Limited
 Transnet RME
 TFR RME RFQ Board
 TFR RME RFQ Board
 Transnet Freight Rail - RME
 PROCUREMENT DEPARTMENT
 0000

REQUEST FOR QUOTATION

Registration Number: 1990/000900/06
 Vat Number : 4720103177

Attention:

Telephone Number :
 Fax Number :
 Vendor Number :500000

Quotation Deadline Date : 15.11.2013
Quotation Deadline Time : 16:00

REQUEST for QUOTATION

Transnet RME
RFQ Number / Date
 6000180864 / 04.11.2013
Contact Person / Telephone
 Troy Stevens / 021 940 1892
Return to VAX Number/EMAIL
 0218100000 / TCPtendersCapeTown@Transnet.net

Item	Material	Description	RFQ Qty	UoM	Required Del date	Confirm Del date	Unit Price Excl	Total Price Excl
------	----------	-------------	---------	-----	-------------------	------------------	-----------------	------------------

Delivery address: Bellville Square store

Please note these requirements must accompany your response:

We also require a list of qualified welders coded welder's certificates.

Previous project completed in steelwork manufacture and references (3 years experience)

Requester and Delivery Address:

Richard Carswell - Transnet Freight Rail (RME)
 Deliver to Bellville Square Bellville South
 Western Cape

Tel: Richard Carswell 0219401813 & 0834556391
 Cell: Jeff Niemand 0834556385
 Email: richard.carswell@transnet.net
 Fax: 021 9401938

If you are unable to quote for this enquiry, please submit a NO QUOTE, with a short reason, if possible, for not being able to quote.

Otherwise we look forward to receive your quote by the date and time stated.



Transnet SOC Limited
 Transnet RME
 TFR RME RFQ Board
 TFR RME RFQ Board
 Transnet Freight Rail - RME
 PROCUREMENT DEPARTMENT
 0000

REQUEST FOR QUOTATION

Registration Number: 1990/000900/06
 Vat Number : 4720103177

Attention:
 Telephone Number :
 Fax Number :
 Vendor Number :500000

Quotation Deadline Date : 15.11.2013
Quotation Deadline Time : 16:00

REQUEST for QUOTATION
 Transnet RME
RFQ Number / Date
 6000180864 / 04.11.2013
Contact Person / Telephone
 Troy Stevens / 021 940 1892
Return to VAX Number/EMAIL
 0218100000 / TCPtendersCapeTown@Transnet.net

Item	Material	Description	RFQ Qty	UoM	Required Del date	Confirm Del date	Unit Price Excl	Total Price Excl
100030		Backstrap 280mm	200	ea	29.11.2013			

Backstrap 280mm
 Backstrap 280mm HOLE CRS (TMFB 145)

Contact person Jeff Niemand 0834556385

Project number 1414792

Delivery address: Bellville Square store

Please note these requirements must accompany your response:

We also require a list of qualified welders coded welder's certificates.

Previous project completed in steelwork manufacture and references (3 years experience)

Requester and Delivery Address:

Richard Carswell - Transnet Freight Rail (RME)
 Deliver to Bellville Square Bellville South



Transnet SOC Limited
 Transnet RME
 TFR RME RFQ Board
 TFR RME RFQ Board
 Transnet Freight Rail - RME
 PROCUREMENT DEPARTMENT
 0000

REQUEST FOR QUOTATION

Registration Number: 1990/000900/06
 Vat Number : 4720103177

Attention:
 Telephone Number :
 Fax Number :
 Vendor Number :500000

Quotation Deadline Date : 15.11.2013
Quotation Deadline Time : 16:00

REQUEST for QUOTATION
 Transnet RME
RFQ Number / Date
 6000180864 / 04.11.2013
Contact Person / Telephone
 Troy Stevens / 021 940 1892
Return to VAX Number/EMAIL
 0218100000 / TCPtendersCapeTown@Transnet.net

Item	Material	Description	RFQ Qty	UoM	Required Del date	Confirm Del date	Unit Price Excl	Total Price Excl
------	----------	-------------	---------	-----	-------------------	------------------	-----------------	------------------

Western Cape

Tel: Richard Carswell 0219401813 & 0834556391
 Cell: Jeff Niemand 0834556385
 Email: richard.carswell@transnet.net
 Fax: 021 9401938

If you are unable to quote for this enquiry, please submit a NO QUOTE, with a short reason, if possible, for not being able to quote.

Otherwise we look forward to receive your quote by the date and time stated.

00040		Base plate	60	ea	29.11.2013			
-------	--	------------	----	----	------------	--	--	--

Base plate
 Base plate tub CL 280mm hole CRS no77mm hole required (TMFB-135)

Contact person Jeff Niemand 0834556385

Project number 1414792

Delivery address: Bellville Square store

Transnet SOC Limited
 Transnet RME
 TFR RME RFQ Board
 TFR RME RFQ Board
 Transnet Freight Rail - RME
 PROCUREMENT DEPARTMENT
 0000

REQUEST FOR QUOTATION

Registration Number: 1990/000900/06
 Vat Number : 4720103177

**Attention:**

Telephone Number :
 Fax Number :
 Vendor Number :500000

Quotation Deadline Date : 15.11.2013
Quotation Deadline Time : 16:00

REQUEST for QUOTATION

Transnet RME
RFQ Number / Date
 6000180864 / 04.11.2013
Contact Person / Telephone
 Troy Stevens / 021 940 1892
Return to VAX Number/EMAIL
 0218100000 / TCPtendersCapeTown@Transnet.net

Item	Material	Description	RFQ Qty	UoM	Required Del date	Confirm Del date	Unit Price Excl	Total Price Excl
------	----------	-------------	---------	-----	-------------------	------------------	-----------------	------------------

Please note these requirements must accompany your response:

We also require a list of qualified welders coded welder's certificates.

Previous project completed in steelwork manufacture and references (3 years experience)

Requester and Delivery Address:

Richard Carswell - Transnet Freight Rail (RME)
 Deliver to Bellville Square Bellville South
 Western Cape

Tel: Richard Carswell 0219401813 & 0834556391
 Cell: Jeff Niemand 0834556385
 Email: richard.carswell@transnet.net
 Fax: 021 9401938

If you are unable to quote for this enquiry, please submit a NO QUOTE, with a short reason, if possible, for not being able to quote.

Otherwise we look forward to receive your quote by the date and time stated.



Transnet SOC Limited
 Transnet RME
 TFR RME RFQ Board
 TFR RME RFQ Board
 Transnet Freight Rail - RME
 PROCUREMENT DEPARTMENT
 0000

REQUEST FOR QUOTATION

Registration Number: 1990/000900/06
 Vat Number : 4720103177

Attention:
 Telephone Number :
 Fax Number :
 Vendor Number :500000

Quotation Deadline Date : 15.11.2013
Quotation Deadline Time : 16:00

REQUEST for QUOTATION
 Transnet RME
RFQ Number / Date
 6000180864 / 04.11.2013
Contact Person / Telephone
 Troy Stevens / 021 940 1892
Return to VAX Number/EMAIL
 0218100000 / TCPtendersCapeTown@Transnet.net

Item	Material	Description	RFQ Qty	UoM	Required Del date	Confirm Del date	Unit Price Excl	Total Price Excl
00050		Tie bar bracket	50	ea	29.11.2013			

Tie bar bracket
 Tie bar bracket galvanized (TMFB-125)

Contact person Jeff Niemand 0834556385

Project number 1414792

Delivery address: Bellville Square store

Please note these requirements must accompany your response:

We also require a list of qualified welders coded welder's certificates.

Previous project completed in steelwork manufacture and references (3 years experience)

Requester and Delivery Address:

Richard Carswell - Transnet Freight Rail (RME)
 Deliver to Bellville Square Bellville South
 Western Cape



Transnet SOC Limited
 Transnet RME
 TFR RME RFQ Board
 TFR RME RFQ Board
 Transnet Freight Rail - RME
 PROCUREMENT DEPARTMENT
 0000

REQUEST FOR QUOTATION

Registration Number: 1990/000900/06
 Vat Number : 4720103177

Attention:
 Telephone Number :
 Fax Number :
 Vendor Number :500000

Quotation Deadline Date : 15.11.2013
Quotation Deadline Time : 16:00

REQUEST for QUOTATION
 Transnet RME
RFQ Number / Date
 6000180864 / 04.11.2013
Contact Person / Telephone
 Troy Stevens / 021 940 1892
Return to VAX Number/EMAIL
 0218100000 / TCPtendersCapeTown@Transnet.net

Item	Material	Description	RFQ Qty	UoM	Required Del date	Confirm Del date	Unit Price Excl	Total Price Excl
------	----------	-------------	---------	-----	-------------------	------------------	-----------------	------------------

Tel: Richard Carswell 0219401813 & 0834556391
 Cell: Jeff Niemand 0834556385
 Email: richard.carswell@transnet.net
 Fax: 021 9401938

If you are unable to quote for this enquiry, please submit a NO QUOTE, with a short reason, if possible, for not being able to quote.

Otherwise we look forward to receive your quote by the date and time stated.



Transnet SOC Limited
 Transnet RME
 TFR RME RFQ Board
 TFR RME RFQ Board
 Transnet Freight Rail - RME
 PROCUREMENT DEPARTMENT
 0000

REQUEST FOR QUOTATION

Registration Number: 1990/000900/06
 Vat Number : 4720103177

Attention:

Telephone Number :
 Fax Number :
 Vendor Number : 500000

Quotation Deadline Date : 15.11.2013
Quotation Deadline Time : 16:00

REQUEST for QUOTATION

Transnet RME
RFQ Number / Date
 6000180864 / 04.11.2013
Contact Person / Telephone
 Troy Stevens / 021 940 1892
Return to VAX Number/EMAIL
 0218100000 / TCPtendersCapeTown@Transnet.net

Delivery Address

TFR RME Cape Town
 De Gatt Complex, Behind Propne
 Bellville South, Cape Tow
 7530

This RFQ is subject to the following conditions:

1. Price/s : The price/s quoted in SA currency and is excluding of V.A.T
2. Delivery : The price/s quoted should include delivery cost to the delivery address stated on the RFQ
3. Returnables : A valid tax clearance certificate and BBBEE certificate from a SANAS accredited verification agency attached to quotation for all quotes above R30 000.
Please note that only the official Transnet RFQ will be accepted and all other correspondence to be attached to the original
4. Safety : To confirm to Transnet Capital Projects Health & Safety plan and specification; HAS-std-0001, copy available on request.
5. Confirmation: To confirm your participation in this tender process please sign and return this document as immediate effect prior to the quotation deadline.
6. Negotiations: The Employer may elect to negotiate the final terms of the contract/order with the preferred tenderer in accordance with Clauses F.2.17 and F.3.13 of the CIDB Standard Conditions of Tender. A copy of which is available upon request.

 Signature

 Date

ORIGINAL FRAME SIZE
OORSPRONKLIKE RAAMGROOTTE 267 x 180



MAST Ø - TRACK Ø MAS H - SPOOR H	DEVELOPED LENGTH ONTWIKKELDE LENGTE	DIMENSION A AFMETING A	STORES MAGASYN	ITEM NO
2750	3015	2765	54/110227	
3200	3450	3200	54/110283	6
3700	3930	3680	54/110231	

AMENDMENTS.
WYSIGINGS.

NO.	NAME NAAM.	DATE DATUM.
6	W.R.G.	28-3-78

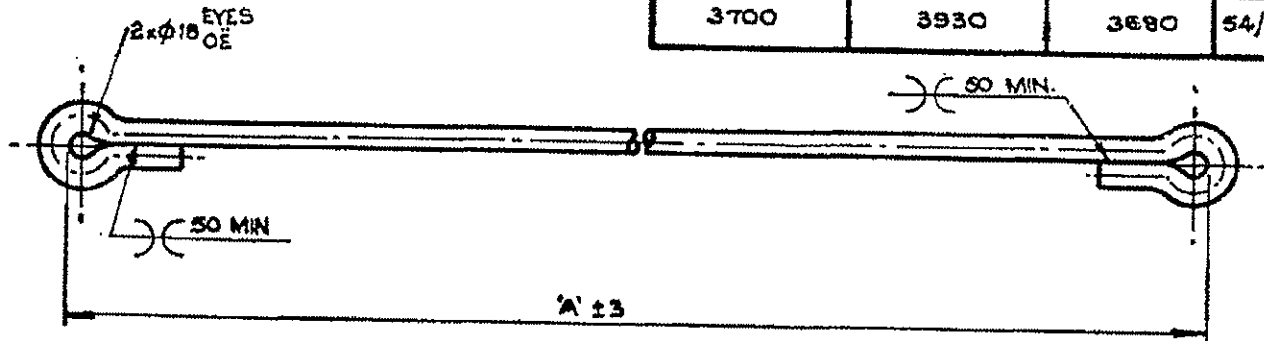

REDRAWN. ASSY. NO'S
FOR UNIVERSAL
COLUMNS ADDED.
WELDING NOTE ADDED.
OORGETEKEN. SAMES
NO'S. VIR UNIVERSELE
KOLOMME BYGEVOEG
D.O.REF.
TK-VERW. Y76/43

7. W.R.G. 78-06-30

ASSY. DRG. NO'S 40
AND SI REMOVED.
SAMES-TEK. NO'S 40
EN SI VERWYDER.
D.O.REF.
TK-VERW. Y77/108

DIMENSIONS : MILLIMETRES.
AFMETINGS : MILLIMETER.

MATERIAL - MATERIAAL
STEEL, ROUND. Ø 16
STAAL, ROND. Ø 16
SPEC. CME 9 SYM. 7
SPES. CME 9 SIM. 7
STORES ITEM
MAGASYNITEM NO. 11/21532
OR COMMERCIAL GRADE.
OF HANDELSGRAAD.

NOTE : WELDING TO CONFORM TO
OPMERKING : SWEISWERK MOET VOLDOEN AAN B.S. 5135
FABRICATION : FORM EYES AT 850°-900°C AND ALLOW TO COOL.
FREELY IN AIR.
VERVAARDIGING : VORM OE TEEN 850°-900°C EN LAAT
VRYLIK IN LUG AFKOEL.
FINISH : ZINC COAT TO SPEC
AFWERKING : SAKBEDEK VOLGENS SPES. S.A.B.S. 763.

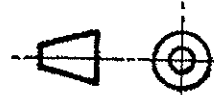

CEE TMG 60
CEE TMG 39,49

DRN. GET. A.J.S.	GEN. TOLERANCES: LIN. ± 1 ALG. TOLERANSIES: ANG./HOEK. —	
TRCD. NGT. Y. SWART	D.O.REF. TK-VERW. —	ENG. IR. —
CKD. NGS. F.W.C.	DATE. DATUM. 8-4-65	R. BARNES. for R.S.
CHIEF ELECTRICAL ENGINEER. ELEKTROTEGNIESE HOOFINGENIEUR. S.A.S. JOHANNESBURG		

TIE-BAR FOR TUBULAR CANTILEVERS.
NON STAGGERED CATENARY
KOPPELSTAAF VIR BUISVORMIGE VRYDRAERARMS.
NIE - GESLINGERDE DRAKABEL

ASSY. DRG./SAMES-TEK.
DRAWING. NO. CEE
TEKENING.

TMHB 3

A4
A4

ITEM	DESCRIPTION	QTY	STORES ITEM NO	DRG NO CEE-	AMENDMENTS		
1	CLAMPING BRACKET	1	—————	TMFB-138	NO	NAME	DATE
2	EARTH WIRE CLEAT	1	—————	TMHF-20	1	J v DYK	2000-10-30

REDRAWN. DRG NO
WAS CEE-TMF-202.
DO REF T95/067

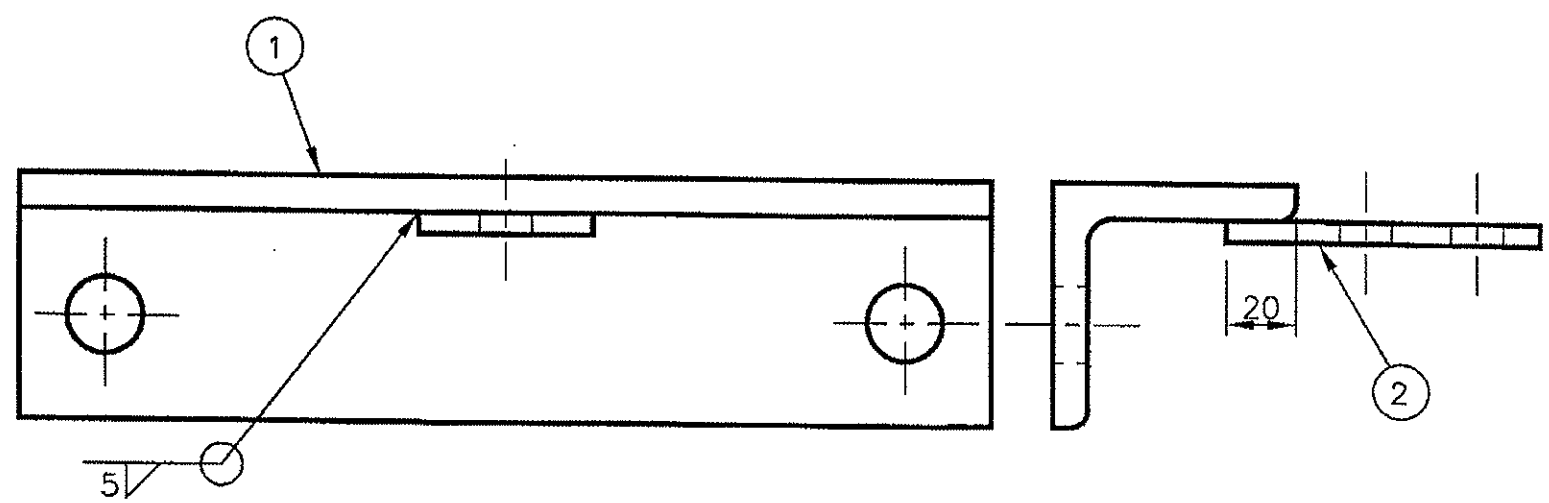

NOTE
WELDING TO CONFORM TO SPEC. B.S. 5135.
FINISH
ZINC COAT TO SPEC. SABS 763 FOR CONDITIONS IN SITU.

DIMENSIONS: mm
SCALE: 1:2

DO REF: Y76/43	GEN TOL: LIN± 1 ANG± -
DRN: B v RENSBURG	CKD: W R G DATE: 78-03-31
ENG: J de VILLIERS	F PIENAAR for CHIEF ENG

CLAMPING BRACKET
EARTH WIRE CLEAT
CANTILEVER & BOOM STRUCTURES
203 x 203 UNIVERSAL COLUMNS.

A4
 DRG NO **CEE-**
TMFB-168
 SHT — OF —

INFRASTRUCTURE
(ELECTRICAL)



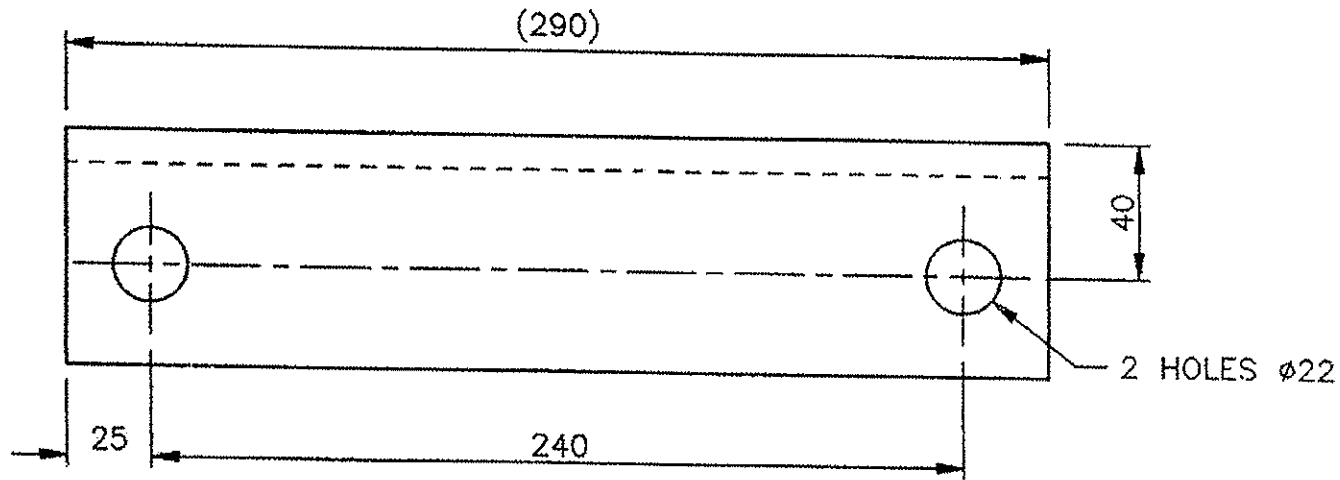

FINISH
 ITEM 1: ZINC COAT TO SABS 763 FOR CONDITIONS IN SITU.
 ITEM 2: NOT ZINC COATED.

AMENDMENTS		
NO	NAME	DATE
1	JVT	97-09-05
REVISED, DRAWING NO WAS TMHA-90. DO REF: T96/021		

DIMENSIONS: mm
 SCALE: 1:2

MATERIAL: STORES ITEM NO: 11/14508, STEEL, ANGLE, 70 x 70 x 10 x 290 LG.

DO REF: Y76/43	GEN TOL: LIN± 1,5	ANG± -
DRN: B v RENSBURG	CKD: W.R.G.	DATE: 78-03-31
for ENG: I DE V	F PIENAAR	for CHIEF ENG

CLAMPING BRACKET
 203 x 203 UNIVERSAL COLUMNS



DRG NO **CEE-**
TMFB-145

INFRASTRUCTURE
 (ELECTRICAL)



SHT - OF -

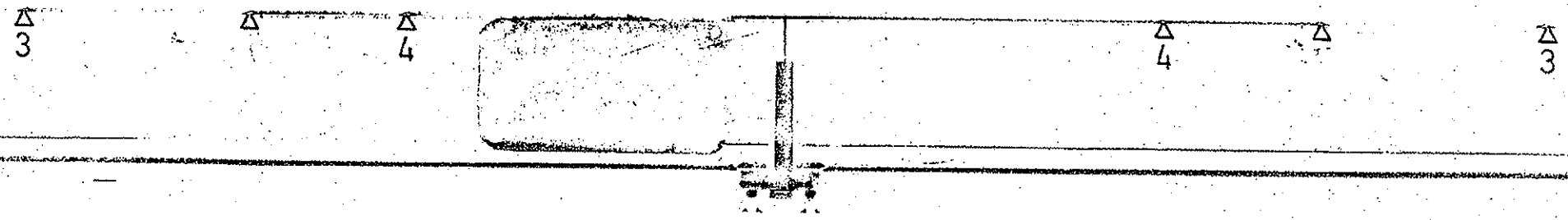
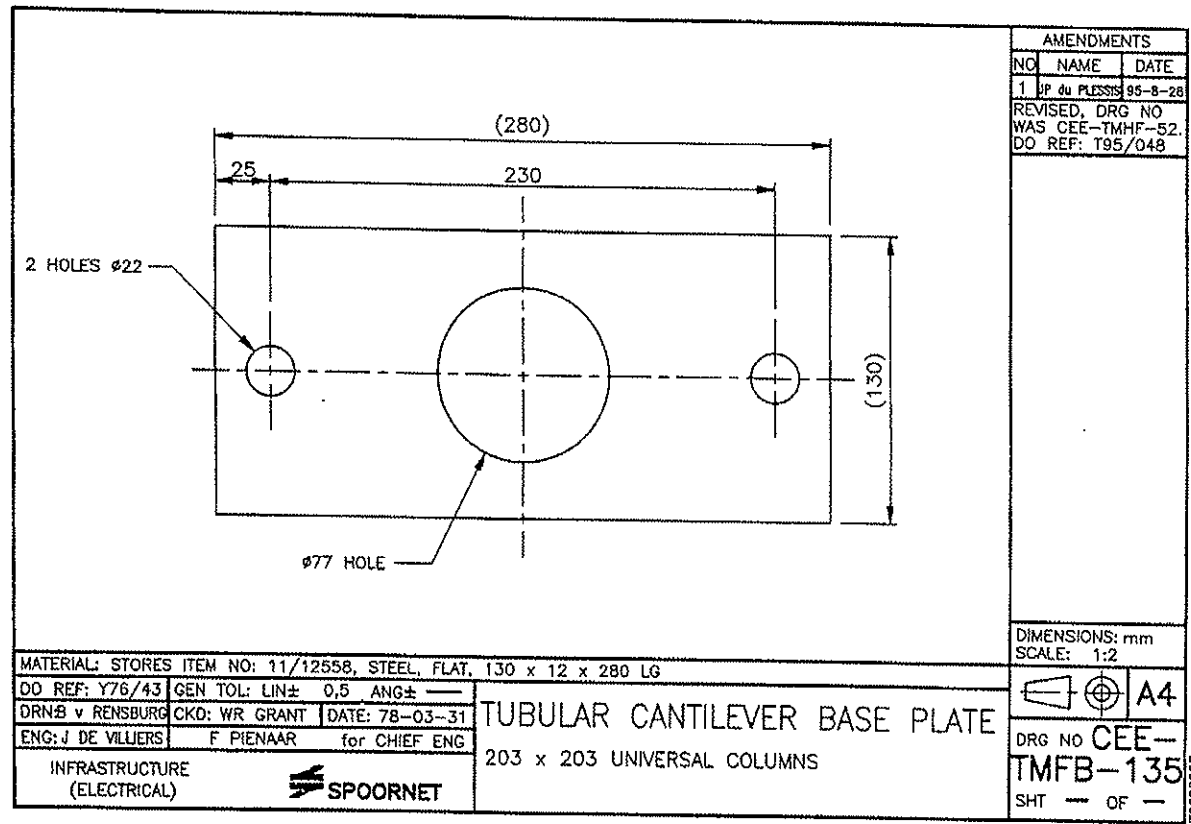

AMENDMENTS		DRG NO CEE-	STORES ITEM NO	QTY	DESCRIPTION	ITEM
NO	NAME	DATE	1	1	CLAMPING BRACKET	1
			2	2	CLEVIS PLATE	2

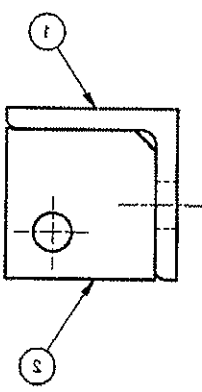
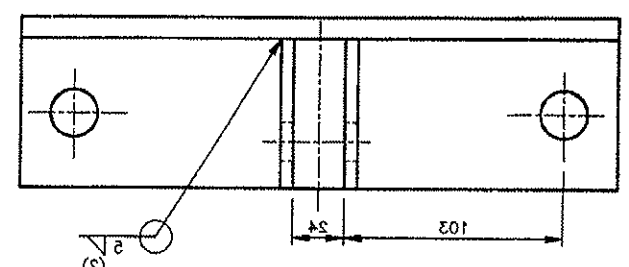
NOTE
WELDING TO CONFORM TO BS 5135
ZINC COAT TO SABS 763 AFTER WELDING FOR CONDITION IN SITU

TIE WIRE BRACKET
TUBULAR CANTILEVERS
208 x 204 AND 218 x 208 UC AND
CONCRETE MASTS

SPORNET
INFRASTRUCTURE
(ELECTRICAL)

DO REF: 194\044 GEN FOR: LINE 1 ANG ± ---
DRN: A PIETERSE CKD: LE WOOD DATE: 24-09-08
ENG: T. SUDWORTHY JP DU PLESSIS for CHIEF ENG

STORES ITEM NO. _____
 DIMENSIONS: mm
 SCALE: 1:2

 DRG NO CEE-
TMFB-122
 SHT - OF -

34300007

3

4

4

3