



Transnet SOC Limited  
Transnet RME

REQUEST FOR QUOTATION

TFR RME RFQ Board  
TFR RME RFQ Board  
Transnet Freight Rail - RME  
PROCUREMENT DEPARTMENT

Registration Number: 1990/000900/06  
Vat Number : 4720103177

**Attention:**  
  
Telephone Number :  
Fax Number :  
Vendor Number :500000

**Quotation Deadline Date : 04.10.2013**  
**Quotation Deadline Time : 16:00**

**REQUEST for QUOTATION**  
Transnet RME  
**RFQ Number / Date**  
6000175603 / 23.09.2013  
**Contact Person Telephone**  
Troy Stevens 021 940 1892  
**Return to VAX Number/EMAIL**  
0218100000 / TCPtendersCapeTown@Transnet.net

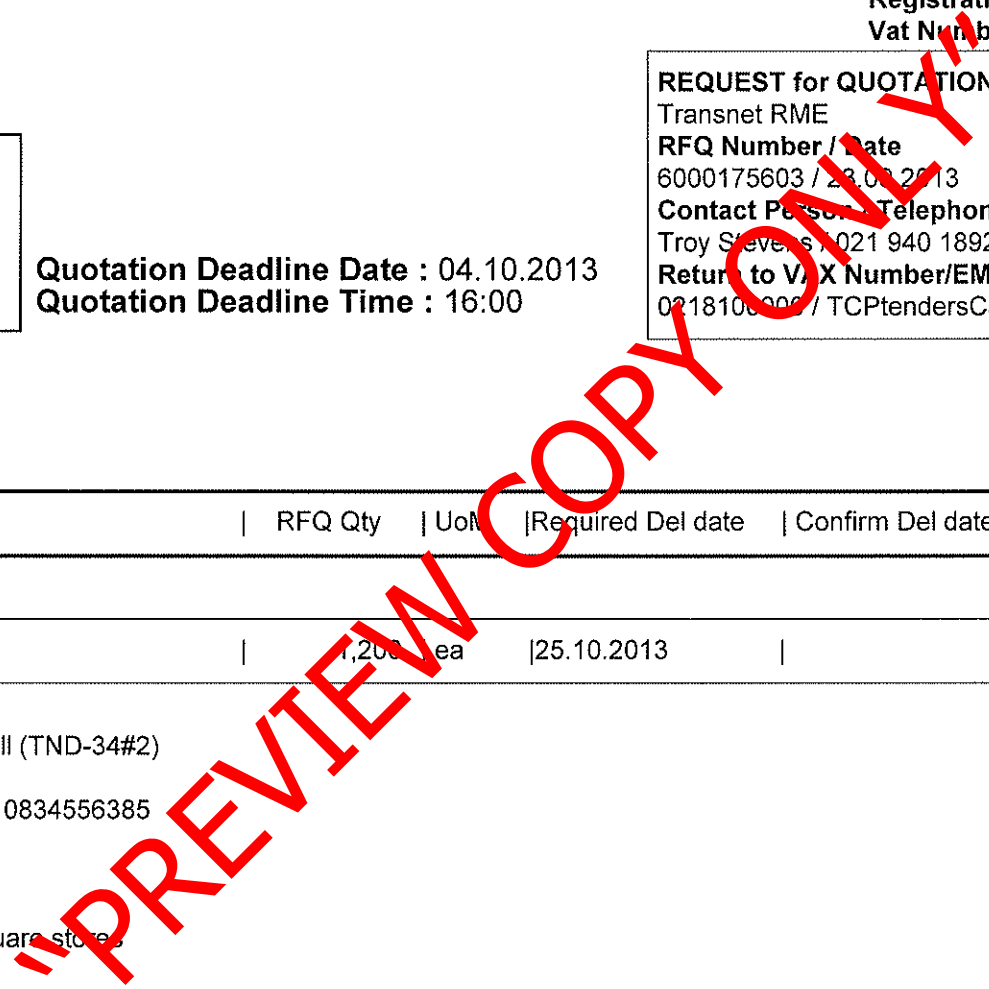

Item	Material	Description	RFQ Qty	Unit	Required Del date	Confirm Del date	Unit Price Excl	Total Price Excl
00010		OHTE fitting	1,200	ea	25.10.2013			

OHTE fitting  
Registration tube 1900mm pull (TND-34#2)

Contact person Jeff Niemand 0834556385

Project number 1414792

Delivery address: Bellville Square stores

Requester and Delivery Address:

Richard Carswell - Transnet Freight Rail (RME)  
Deliver to Bellville Square Bellville South  
Western Cape

Tel: Richard Carswell 0219401813 & 0834556391  
Cell: Jeff Niemand 0834556385



Transnet SOC Limited  
 Transnet RME  
 TFR RME RFQ Board  
 TFR RME RFQ Board  
 Transnet Freight Rail - RME  
 PROCUREMENT DEPARTMENT  
 0000

REQUEST FOR QUOTATION

Registration Number: 1990/000900/06  
 Vat Number : 4720103177

**Attention:**  
 Telephone Number :  
 Fax Number :  
 Vendor Number :500000

**Quotation Deadline Date : 04.10.2013**  
**Quotation Deadline Time : 16:00**

**REQUEST for QUOTATION**  
 Transnet RME  
**RFQ Number / Date**  
 6000175603 / 23.09.2013  
**Contact Person Telephone**  
 Troy Stevens 021 940 1892  
**Return to VAX Number/EMAIL**  
 0218100000 / TCPtendersCapeTown@Transnet.net

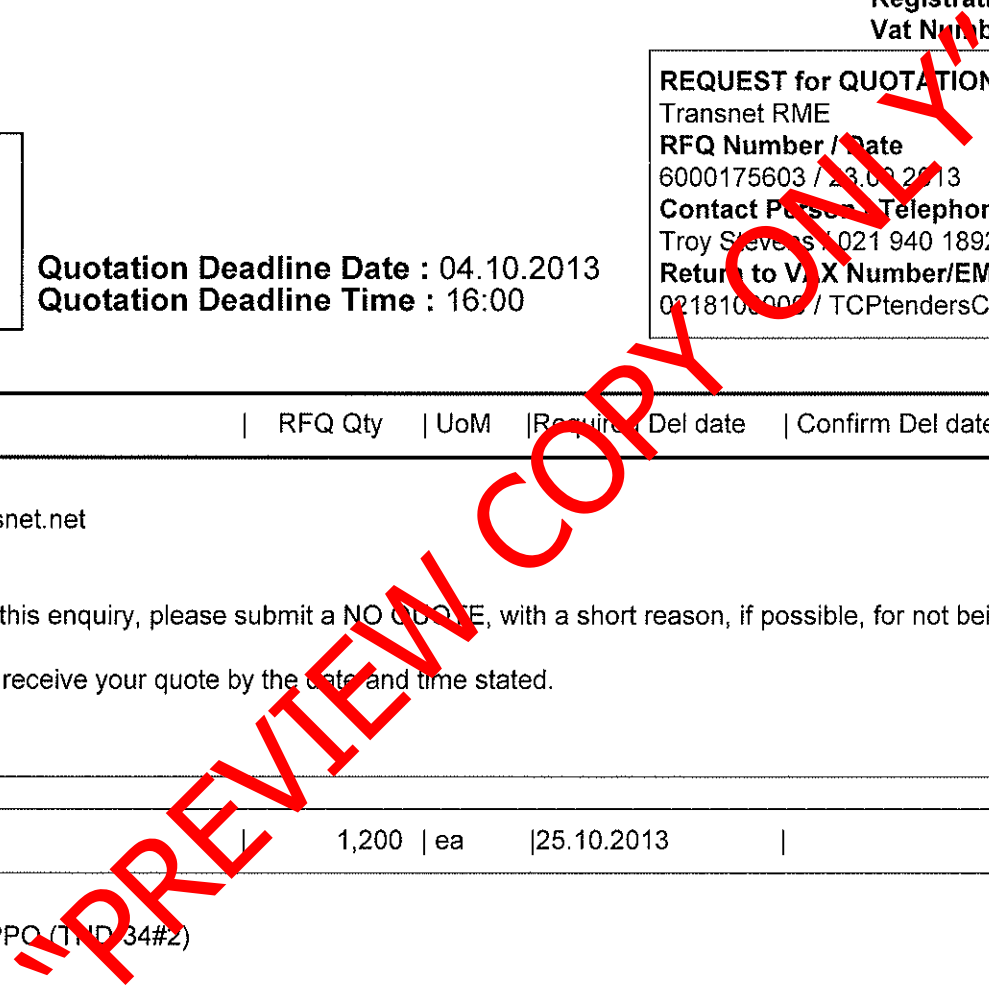

Item	Material	Description	RFQ Qty	UoM	Required Del date	Confirm Del date	Unit Price Excl	Total Price Excl
------	----------	-------------	---------	-----	-------------------	------------------	-----------------	------------------

Email: richard.carswell@transnet.net  
 Fax: 021 9401938

If you are unable to quote for this enquiry, please submit a NO QUOTE, with a short reason, if possible, for not being able to quote.  
 Otherwise we look forward to receive your quote by the date and time stated.

00020		OHTE fitting	1,200	ea	25.10.2013			
-------	--	--------------	-------	----	------------	--	--	--

OHTE fitting  
 Registration tube 30300mm PPO (T1D 34#2)  
 Contact person Jeff Niemand 0834556385  
 Project number 1414792  
 Delivery address: Bellville Square stores



Transnet SOC Limited  
 Transnet RME  
 TFR RME RFQ Board  
 TFR RME RFQ Board  
 Transnet Freight Rail - RME  
 PROCUREMENT DEPARTMENT  
 0000

REQUEST FOR QUOTATION

Registration Number: 1990/000900/06  
 Vat Number : 4720103177

**Attention:**  
 Telephone Number :  
 Fax Number :  
 Vendor Number :500000

**Quotation Deadline Date : 04.10.2013**  
**Quotation Deadline Time : 16:00**

**REQUEST for QUOTATION**  
 Transnet RME  
**RFQ Number / Date**  
 6000175603 / 23.09.2013  
**Contact Person Telephone**  
 Troy Stevens / 021 940 1892  
**Return to VAX Number/EMAIL**  
 0218100000 / TCPtendersCapeTown@Transnet.net

PREVIEW COPY

Item	Material	Description	RFQ Qty	UoM	Required Del date	Confirm Del date	Unit Price Excl	Total Price Excl
00030		OHTE fitting	4,000	ea	25.10.2013			
OHTE fitting Clip dropper S/Steel 161mm catenary (TND-36)  Contact person Jeff Niemand 0834556385  Project number 1414792  Delivery address: Bellville Square stores								
00040		OHTE fitting	2,000	ea	25.10.2013			
OHTE fitting Pivot pin M16x160mm L inc S/S split pin (TX-119)  Contact person Jeff Niemand 0834556385  Project number 1414792								



**Transnet SOC Limited**  
**Transnet RME**  
 TFR RME RFQ Board  
 TFR RME RFQ Board  
 Transnet Freight Rail - RME  
 PROCUREMENT DEPARTMENT  
 0000

**REQUEST FOR QUOTATION**

**Registration Number: 1990/000900/06**  
**Vat Number : 4720103177**

**Attention:**  
 Telephone Number :  
 Fax Number :  
 Vendor Number :500000

**Quotation Deadline Date : 04.10.2013**  
**Quotation Deadline Time : 16:00**

**REQUEST for QUOTATION**  
 Transnet RME  
**RFQ Number / Date**  
 6000175603 / 23.09.2013  
**Contact Person Telephone**  
 Troy Stevens 021 940 1892  
**Return to VAX Number/EMAIL**  
 0218100000 / TCPtendersCapeTown@Transnet.net

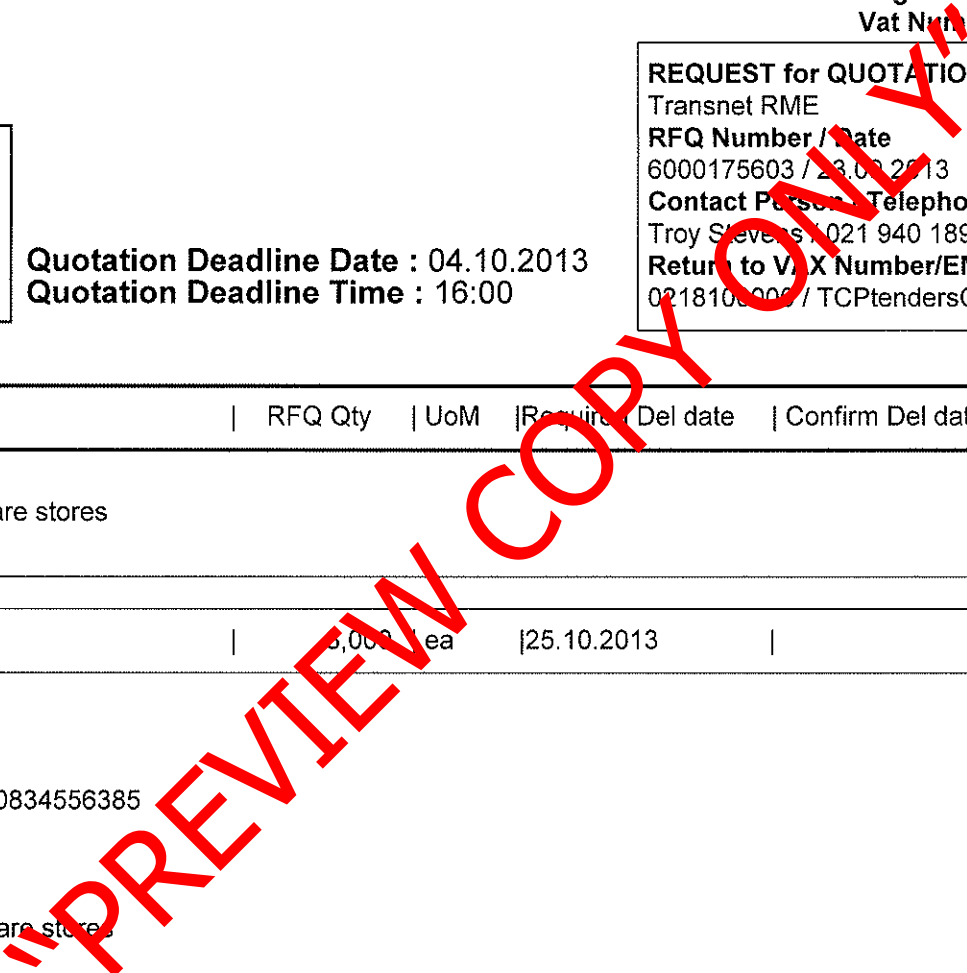

Item	Material	Description	RFQ Qty	UoM	Required Del date	Confirm Del date	Unit Price Excl	Total Price Excl
------	----------	-------------	---------	-----	-------------------	------------------	-----------------	------------------

Delivery address: Bellville Square stores

00050		OHTE fitting	3,000	ea	25.10.2013			
-------	--	--------------	-------	----	------------	--	--	--

OHTE fitting  
 Clevis pin 16x55L (TX-66)

Contact person Jeff Niemand 0834556385

Project number 1414792

Delivery address: Bellville Square stores

Requester and Delivery Address:

Richard Carswell - Transnet Freight Rail (RME)  
 Deliver to Bellville Square Bellville South  
 Western Cape

Tel: Richard Carswell 0219401813 & 0834556391  
 Cell: Jeff Niemand 0834556385  
 Email: richard.carswell@transnet.net



Transnet SOC Limited  
 Transnet RME  
 TFR RME RFQ Board  
 TFR RME RFQ Board  
 Transnet Freight Rail - RME  
 PROCUREMENT DEPARTMENT  
 0000

REQUEST FOR QUOTATION

Registration Number: 1990/000900/06  
 Vat Number : 4720103177

**Attention:**  
 Telephone Number :  
 Fax Number :  
 Vendor Number :500000

**Quotation Deadline Date : 04.10.2013**  
**Quotation Deadline Time : 16:00**

**REQUEST for QUOTATION**  
 Transnet RME  
**RFQ Number / Date**  
 6000175603 / 23.09.2013  
**Contact Person Telephone**  
 Troy Stevens / 021 940 1892  
**Return to VAX Number/EMAIL**  
 0218100000 / TCPtendersCapeTown@Transnet.net

"PREVIEW COPY ONLY"

Item	Material	Description	RFQ Qty	UoM	Required Del date	Confirm Del date	Unit Price Excl	Total Price Excl
------	----------	-------------	---------	-----	-------------------	------------------	-----------------	------------------

Fax: 021 9401938

If you are unable to quote for this enquiry, please submit a NO QUOTE, with a short reason, if possible, for not being able to quote.

Otherwise we look forward to receive your quote by the date and time stated.

**Transnet SOC Limited**  
**Transnet RME**  
 TFR RME RFQ Board  
 TFR RME RFQ Board  
 Transnet Freight Rail - RME  
 PROCUREMENT DEPARTMENT  
 0000

## REQUEST FOR QUOTATION

Registration Number: 1990/000900/06  
 Vat Number : 4720103177

**Attention:**

Telephone Number :  
 Fax Number :  
 Vendor Number :500000

**Quotation Deadline Date : 04.10.2013**  
**Quotation Deadline Time : 16:00**

**REQUEST for QUOTATION**  
 Transnet RME  
**RFQ Number / Date**  
 6000175603 / 23.09.2013  
**Contact Person Telephone**  
 Troy Stevens / 021 940 1892  
**Return to FAX Number/EMAIL**  
 0218102000 / TCPtendersCapeTown@Transnet.net

**Delivery Address**

TFR RME Cape Town  
 De Gatt Complex, Behind Propne  
 Bellville South, Cape Tow  
 7530

This RFQ is subject to the following conditions:

1. Price/s : The price/s quoted in SA currency and is excluding of V.A.T
2. Delivery : The price/s quoted should include delivery cost to the delivery address stated on the RFQ
3. Returnables : A valid tax clearance certificate and BBBEE certificate from a SANAS accredited verification agency attached to quotation for all quotes above R30 000.  
Please note that only the official Transnet RFQ will be accepted and all other correspondence to be attached to the original
4. Safety : To confirm to Transnet Capital Projects Health & Safety plan and specification; HAS-std-0001, copy available on request.
5. Confirmation: To confirm your participation in this tender process please sign and return this document as immediate effect prior to the quotation deadline.
6. Negotiations: The Employer may elect to negotiate the final terms of the contract/order with the preferred tenderer in accordance with Clauses F.2.17 and F.3.13 of the CIDB Standard Conditions of Tender. A copy of which is available upon request.

\_\_\_\_\_  
 Signature

\_\_\_\_\_  
 Date

ITEM	DESCRIPTION	QTY	STORES NO	DRG NO CEE-	AMENDMENTS
1	TUBE, STEEL $\phi$ 48 OD $\phi$ WALL THICKNESS 4 TO SABS 657 GRADE J40 ERW.	1	(M) 54/7303	---	NO NAME DATE 1 JVT 87-04-07
2	CLEVIS FITTING, LEAD END	2	---	TNB-75	REVISED, DRG NO WAS CEE-TMHH-2 DO REF: T96/001

TYPE	MAST TO TRACK CRS	PULL-OFF CANTI-LEVER	PUSH-PULL-OFF
		LENGTH OF TUBE "L"	LENGTH OF TUBE "L"
I	2750	1600	---
II		---	2730
III	3200	1900	---
IV		---	3030
V	3700	2230	---
VI		---	3360

FINISH  
ZINC COAT TO SABS 781 FOR CONDITIONS IN SITU.

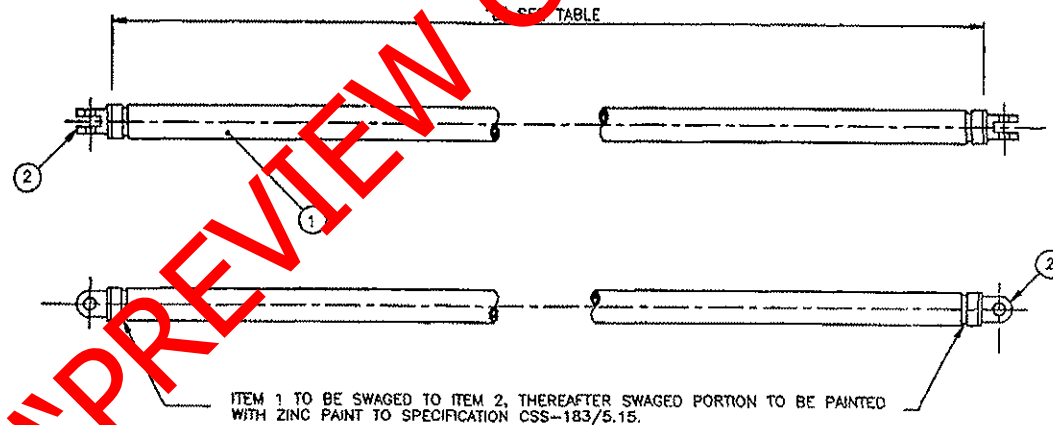

"PREVIEW COPY ONLY"

DO REF: T80/65	GEN TOL: LIN $\pm$ 3	ANG $\pm$ 1'
DRN: T HUMAN	CKD: RA McMILLAN	DATE: 80-02-13
ENG: ---	GA WILLIAMS	for CHIEF ENG
INFRASTRUCTURE (ELECTRICAL)	SPOORNET	

REGISTERING ARM ASSEMBLY

STORES ITEM NO	---
DIMENSIONS:	mm
SCALE:	1:5
	A2
DRAWING NO	CEE-
	TND-34
SHEET	OF

080114

ITEM	DESCRIPTION	QTY	STORES NO	DRG NO CEE-	AMENDMENTS		
					NO	NAME	DATE
1	TUBE, STEEL #48 OD & WALL THICKNESS 4 TO SABS 657 GRADE 340 ERW.	1	(M) 54/7303	---	1	JVT	87-04-07
2	CLEVIS FITTING, LEAD END	2	---	TNB-75	REVISED, DRG NO WAS CEE-TMHH-2 DO REF: T96/001		

TYPE	MAST TO TRACK CRS	PULL-OFF CANTI-LEVER	PUSH-PULL-OFF
		LENGTH OF TUBE "L"	LENGTH OF TUBE "L"
I	2750	1600	---
II		---	2730
III	3200	1900	---
IV		---	3030
V	3700	2230	---
VI		---	3360

FINISH  
ZINC COAT TO SABS 765 FOR CONDITIONS IN SITU.

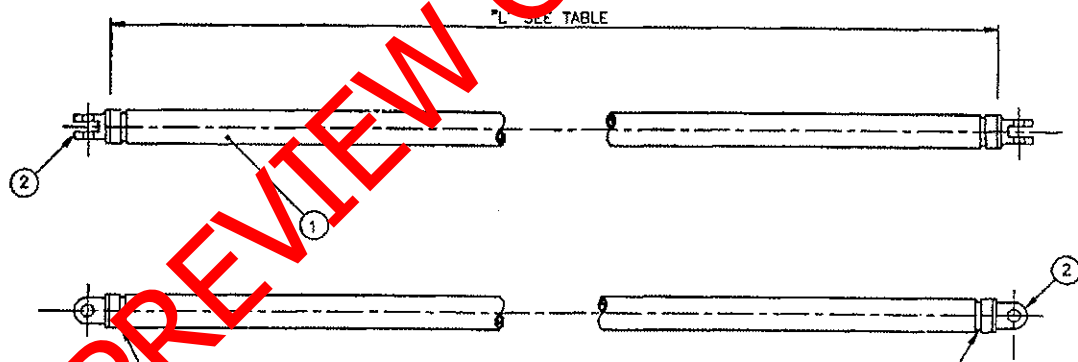

ITEM 1 TO BE SWAGED TO ITEM 2, THEREAFTER SWAGED PORTION TO BE PAINTED WITH ZINC PAINT TO SPECIFICATION CSS-183/5.15.

"PREVIEW COPY ONLY"

DO REF: T80/65	GEN TOL: LIN± 3	ANG± 1'
DRN: T HUMAN	CKD: RA McMILLAN	DATE: 80-02-13
ENG: ---	GA WILLIAMS	for CHIEF ENG
INFRASTRUCTURE (ELECTRICAL)	SPOORNET	

REGISTERING ARM ASSEMBLY

STORES ITEM NO	---
DIMENSIONS:	mm
SCALE:	1:5
	A2
DRAWING NO	CEE-
	TND-34
SHEET	OF ---

1/80117



ITEM	DESCRIPTION	QTY	STORES NO	STORES NO	AMENDMENTS		
1	Cu-Ni-Si 25 x 3 ALLOY x 54 LG	1			NO	NAME	DATE
2	Cu-Ni-Si 25 x 3 ALLOY x 54 LG	1			1	JVT	97-04-07
3	Cu-Ni-Si MACHINE SCREW ALLOY SLOTTED CSK HEAD (SPEC CEE.0063) M8-6g x 20LG	1	54/360B				

REVISED. DRG NO WAS CEE-TN-294.  
DO REF: T96/001

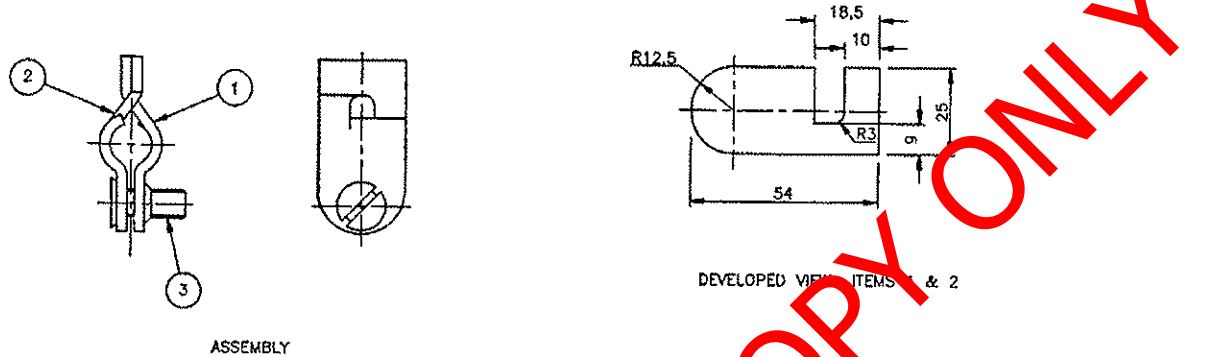

NOTES:

1. DRAW THROUGH FOR INCREASED LENGTH OF THREAD.
2. TO BE READ IN CONJUNCTION WITH SPECIFICATION NO. CEE.0063.
3. ALTERNATIVE MATERIAL: STAINLESS STEEL TO SPEC AISI GR 304.

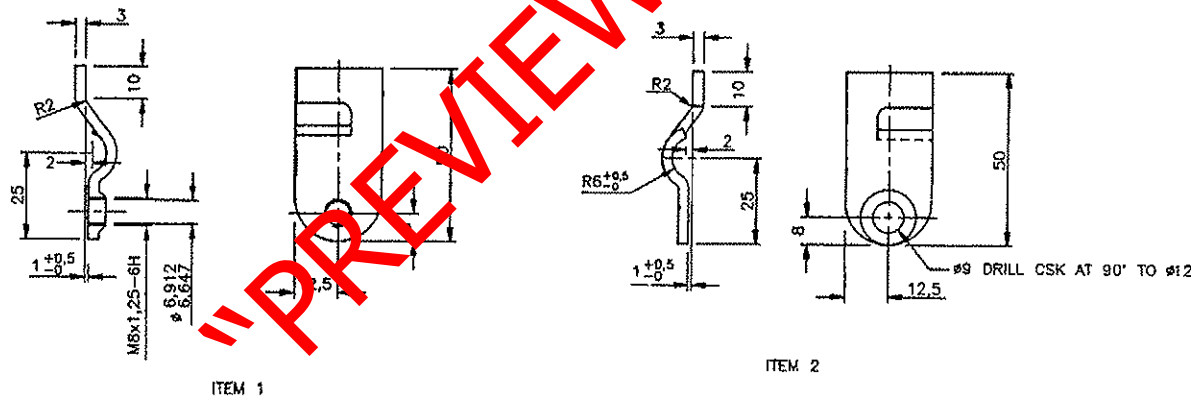

"PREVIEW COPY ONLY"

STORES ITEM NO  
54/552  
DIMENSIONS: mm  
SCALE: 1:1

DO REF: N41/70	GEN TOL: LIN± 0,5	ANG± 1°
DRN: NWL	CKD: HN	DATE: 70-05-04
ENG: F PIENAAR	W PHILLIPS for CHIEF ENG	
INFRASTRUCTURE (ELECTRICAL)	SPOORNET	

CLAMP ELECTRICAL: (DROPPER CLIP)  
CATENARY 80 mm<sup>2</sup> AND 100 mm<sup>2</sup>

A2  
DRAWING NO CEE-TND-36  
SHEET — OF —

ITEM	DESCRIPTION	QTY	STORES ITEM NO	DRG NO CEE-	AMENDMENTS		
1	RIVET, STEEL, SNAP HEAD, $\phi 16$ x 160 LG	1	—————	—————	NO	NAME	DATE
2	LOCKING SPLIT PIN	1	54/3734	TX-54	1	JVT	97-04-07

REVISED. DRG NO  
WAS TN-183.  
DO REF T96/001

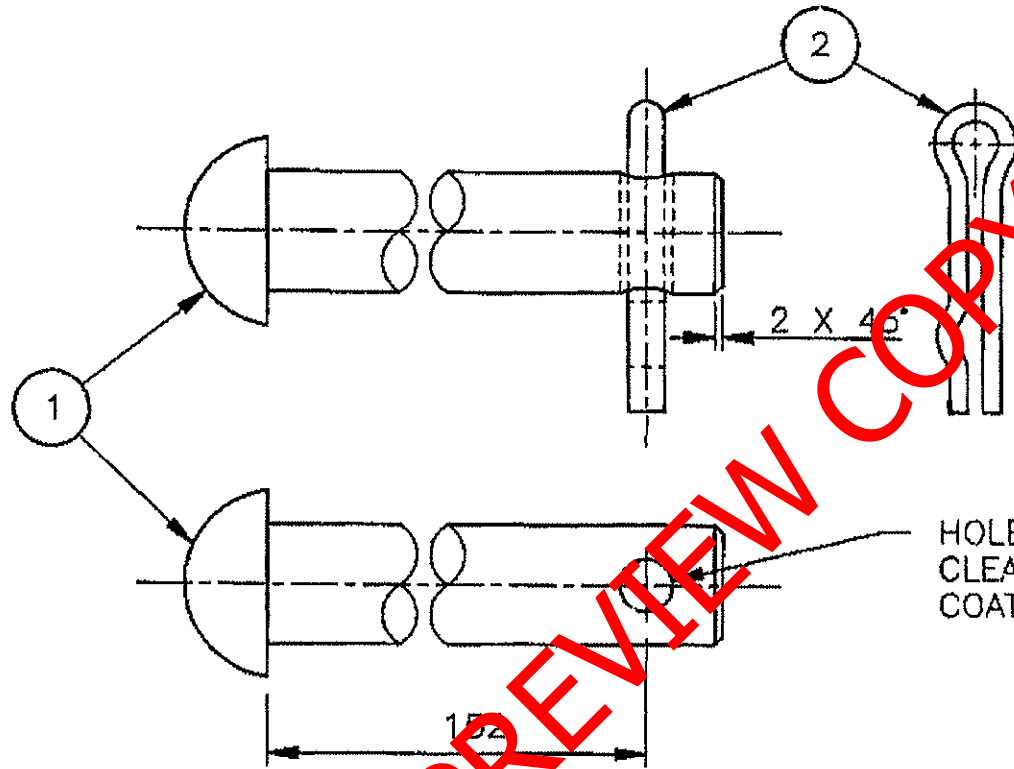

FINISH  
ZINC COAT ITEM 1 TO  
SPEC SABS 763 FOR  
CONDITIONS IN SITU.

HOLE  $\phi 7$  DRILL  
CLEAR AFTER ZINC  
COATING TO  $\phi 6,5$

DIMENSIONS: mm  
SCALE: 1:1



DO REF: T80/65	GEN TOL: LIN $\pm 0,5$	ANG $\pm 1^\circ$
DRN: T HUMAN	CKD: R McMILLAN	DATE: 80-04-02
ENG: ———	GA WILLIAMS	for CHIEF ENG

PIVOT PIN  $\phi 16$   
WITH LOCKING SPLIT PIN

DRG NO CEE-  
**TX-119**  
SHT — OF —

INFRASTRUCTURE  
(ELECTRICAL)



ITEM	DESCRIPTION	QTY	STORES ITEM NO	DRG NO CEE--	AMENDMENTS		
1	RIVET, STEEL, SNAP HEAD, $\phi 16$ x 60 LG	1	01/22722	---	NO	NAME	DATE
2	LOCKING SPLIT PIN	1	54/3734	TX-54	3	J v DYK	94/8/4

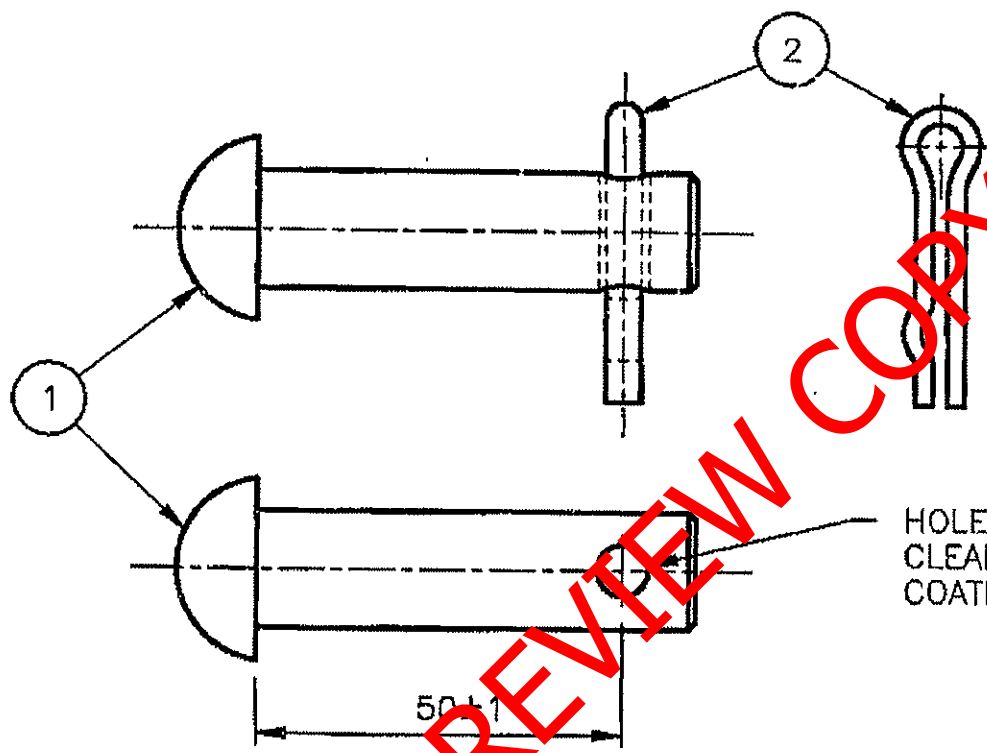

FINISH  
ZINC COAT ITEM 1 TO  
SPEC SABS 763 FOR  
CONDITIONS IN SITU.

HOLE  $\phi 7$  DRILL  
CLEAR AFTER ZINC  
COATING TO  $\phi 6,5$

DIMENSION 50 WAS  
46. TOL REVISED.  
ITEM 1 STORES ITEM  
NO WAS 01/22710.  
DO REF T94/046

STORES ITEM NO.  
54/4020

DIMENSIONS: mm  
SCALE: 1:1



DO REF: C84/70	GEN TOL: LIN $\pm 0,5$	ANG $\pm$ ---
DRN: G.J. v G.	CKD: I.T.	DATE: 70-09-09
ENG: ---	T.C. BROOK	for CHIEF ENG

PIN, STRAIGHT, HEADED,  $\phi 16$   
WITH LOCKING SPLIT PIN

DRG NO CEE--  
TX-66  
SHT --- OF ---

INFRASTRUCTURE  
(ELECTRICAL)

T0000639