



Transnet SOC Limited
Transnet RME

REQUEST FOR QUOTATION

TFR RME RFQ Board
TFR RME RFQ Board
Transnet Freight Rail - RME
PROCUREMENT DEPARTMENT

Registration Number: 1990/000900/06
Vat Number : 4720103177

Attention:

Telephone Number :
Fax Number :
Vendor Number :500000

Quotation Deadline Date : 04.10.2013
Quotation Deadline Time : 16:00

REQUEST for QUOTATION
Transnet RME
RFQ Number / Date
6000175597 / 23.09.2013
Contact Person / Telephone
Troy Stevens / 021 940 1892
Return to FAX Number/EMAIL
0218100000 / TCPTendersCapeTown@Transnet.net

"PREVIEW COPY ONLY"

Item	Material	Description	RFQ Qty	UoM	Required Del date	Confirm Del date	Unit Price Excl	Total Price Excl
00010		OHTE fitting	1,000	ea	25.10.2013			
OHTE fitting Thimble 50/80/100mm Cu Wires (TNB-85) Contact person Jeff Niemand 0834556385 Project number 1414792 Delivery address: Bellville Square stores								
00020		OHTE fitting	4,000	ea	25.10.2013			
OHTE fitting Swivel clamp retainer (TND-25) Contact person Jeff Niemand 0834556385								



Transnet SOC Limited
 Transnet RME
 TFR RME RFQ Board
 TFR RME RFQ Board
 Transnet Freight Rail - RME
 PROCUREMENT DEPARTMENT
 0000

REQUEST FOR QUOTATION

Registration Number: 1990/000900/06
 Vat Number : 4720103177

Attention:
 Telephone Number :
 Fax Number :
 Vendor Number :500000

Quotation Deadline Date : 04.10.2013
Quotation Deadline Time : 16:00

REQUEST for QUOTATION
 Transnet RME
RFQ Number / Date
 6000175597 / 23.09.2013
Contact Person / Telephone
 Troy Stevens / 021 940 1892
Return to FAX Number/EMAIL
 0218100000 / TCPtendersCapeTown@Transnet.net

"PREVIEW COPY ONLY"

Item	Material	Description	RFQ Qty	UoM	Required Del date	Confirm Del date	Unit Price Excl	Total Price Excl
------	----------	-------------	---------	-----	-------------------	------------------	-----------------	------------------

Project number 1414792

Delivery address: Bellville Square stores

100030		OHTE fitting	2,000	ea	25.10.2013			
--------	--	--------------	-------	----	------------	--	--	--

OHTE fitting
 Steady arm assembly (TND-28)

Contact person Jeff Niemand 0834556385

Project number 1414792

Delivery address: Bellville Square stores

100040		OHTE fitting	2,000	ea	25.10.2013			
--------	--	--------------	-------	----	------------	--	--	--

OHTE fitting
 Swivel clip assembly 107mm (TND-33)



Transnet SOC Limited
 Transnet RME
 TFR RME RFQ Board
 TFR RME RFQ Board
 Transnet Freight Rail - RME
 PROCUREMENT DEPARTMENT
 0000

REQUEST FOR QUOTATION

Registration Number: 1990/000900/06
 Vat Number : 4720103177

Attention:
 Telephone Number :
 Fax Number :
 Vendor Number :500000

Quotation Deadline Date : 04.10.2013
Quotation Deadline Time : 16:00

REQUEST for QUOTATION
 Transnet RME
RFQ Number / Date
 6000175597 / 23.09.2013
Contact Person / Telephone
 Troy Stevens / 021 940 1892
Return to FAX Number/EMAIL
 02181 00000 / TCPtendersCapeTown@Transnet.net

"PREVIEW COPY ONLY"

Item	Material	Description	RFQ Qty	UoM	Required Del date	Confirm Del date	Unit Price Excl	Total Price Excl
------	----------	-------------	---------	-----	-------------------	------------------	-----------------	------------------

Contact person Jeff Niemand 0834556385
 Project number 1414792
 Delivery address: Bellville Square stores



Transnet SOC Limited
 Transnet RME
 TFR RME RFQ Board
 TFR RME RFQ Board
 Transnet Freight Rail - RME
 PROCUREMENT DEPARTMENT
 0000

REQUEST FOR QUOTATION

Registration Number: 1990/000900/06
 Vat Number : 4720103177

Attention:

Telephone Number :
 Fax Number :
 Vendor Number :500000

Quotation Deadline Date : 04.10.2013
Quotation Deadline Time : 16:00

REQUEST for QUOTATION
 Transnet RME
RFQ Number / Date
 6000175597 / 23.09.2013
Contact Person / Telephone
 Troy Stevens / 021 940 1892
Return to FAX Number/EMAIL
 0218100000 / TCPTendersCapeTown@Transnet.net

"PREVIEW COPY"

Delivery Address

TFR RME Cape Town
 De Gatt Complex, Behind Propne
 Bellville South, Cape Tow
 7530

This RFQ is subject to the following conditions:

1. Price/s : The price/s quoted in SA currency and is excluding of V.A.T
2. Delivery : The price/s quoted should include delivery cost to the delivery address stated on the RFQ
3. Returnables : A valid tax clearance certificate and BBBEE certificate from a SANAS accredited verification agency attached to quotation for all quotes above R30 000.
 Please note that only the official Transnet RFQ will be accepted and all other correspondence to be attached to the original
4. Safety : To confirm to Transnet Capital Projects Health & Safety plan and specification; HAS-std-0001, copy available on request.
5. Confirmation: To confirm your participation in this tender process please sign and return this document as immediate effect prior to the quotation deadline.
6. Negotiations: The Employer may elect to negotiate the final terms of the contract/order with the preferred tenderer in accordance with Clauses F.2.17 and F.3.13 of the CIDB Standard Conditions of Tender. A copy of which is available upon request.

 Signature

 Date

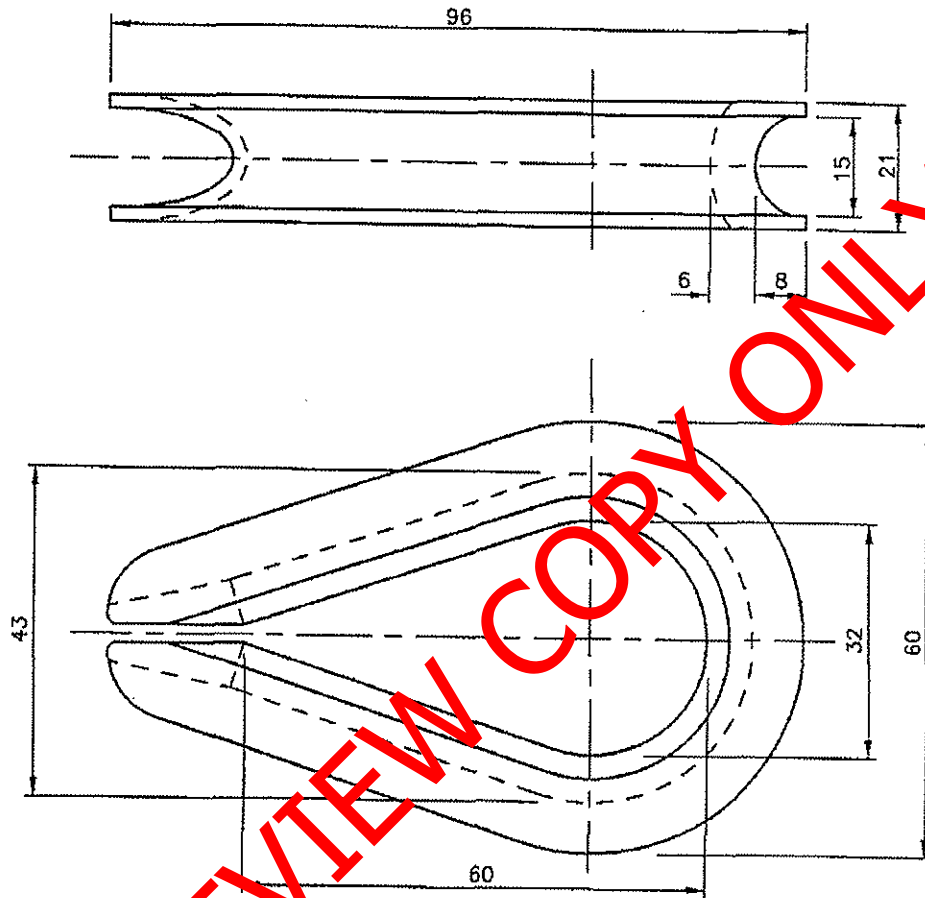

AMENDMENTS		
NO	NAME	DATE
1	JVT	2000-10-30

REVISED, DRG NO WAS CEE-TN-292.
DO REF: T96/001

STORES ITEM NO.
54/5264

DIMENSIONS: mm
SCALE: NTS



DRG NO CEE-
TNB-85
SHT - OF -

FINISH
ZINC COAT TO SABS 763 FOR CONDITIONS IN SITU.

MATERIAL: ITEM NO 11/ ———, STEEL SEE SPEC SABS 811

DO REF: J27/68 GEN TOL: LIN± 0,5 ANG± 1°

DRN: L N CKD: E F J DATE: 68-03-27

ENG: D McKAY W PHILLIPS for CHIEF ENG

CENTRAL DRAWING OFFICE SPOORNET

ROPE THIMBLE

WIRE SIZE - 100mm²

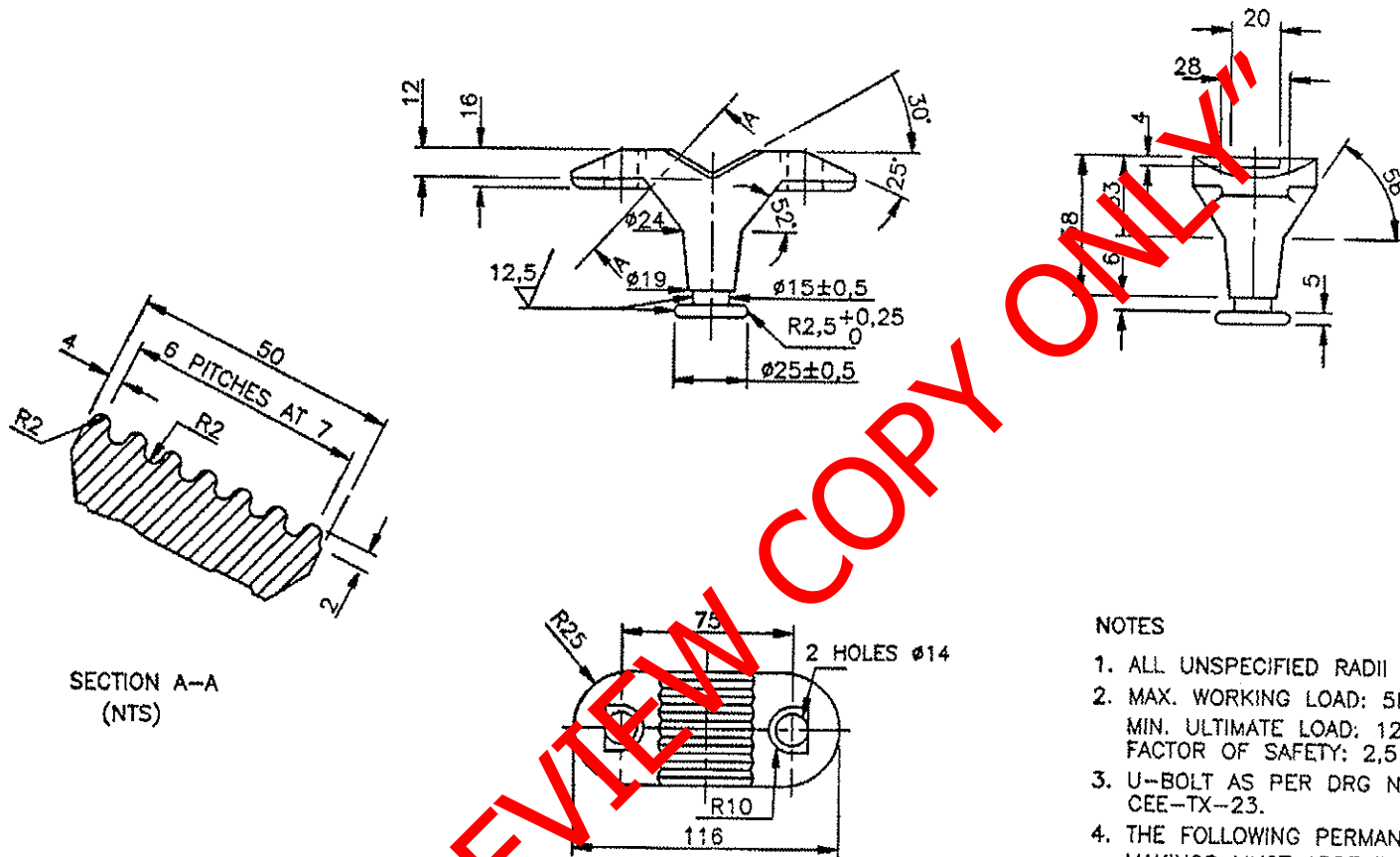

SECTION A-A
(NTS)

NOTES

1. ALL UNSPECIFIED RADII R4.
2. MAX. WORKING LOAD: 5KN
MIN. ULTIMATE LOAD: 12,5KN
FACTOR OF SAFETY: 2,5
3. U-BOLT AS PER DRG NO CEE-TX-23.
4. THE FOLLOWING PERMANENT MAKINGS MUST APPEAR ON THIS ARTICLE:
a. SPOORNET b. MAKER'S IDENTIFICATION c. BATCH NUMBER.
5. FINISH: ZINC COAT TO SABS 763 FOR CONDITIONS IN SITU.

AMENDMENTS

NO	NAME	DATE
1	JVT	95-09-13
REVISED, JRG NO WAS CEE-TN-360. DO REF: T95/052		
2	JVT	97-05-07
DIMENSION $\phi 25 \pm 0,5$ INCORRECTLY SHOWN AS 15. DO REF: T97/008		

MATERIAL: ITEM NO _____ SPHEROIDAL GRAPHITE IRON TO SPEC SABS 936 GRADE SG 50

DO REF: T2/84/21	GEN TOL: LIN \pm 1,0	ANG \pm 1
DRN: G ABRAHAM	CKD: _____	DATE: 84-03-02
ENG: R BUSH	P.P.L.C.	for CHIEF ENG

ELECTRICAL CLAMP

SWIVEL CLAMP RETAINER FOR 107/161 mm² Cu CONTACT WIRE

INFRASTRUCTURE
(ELECTRICAL)



STORES ITEM NO
54/5215

DIMENSIONS: mm
SCALE: 1:2



DRAWING NO CEE-
TND-25

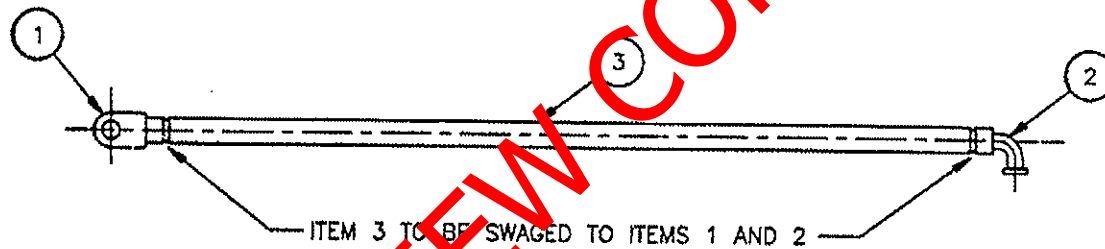

SHEET - OF -

ITEM	DESCRIPTION	QTY	STORE ITEM NO.	DRG NO CEE-	AMENDMENTS		
1	CLEVIS FITTING	1	_____	TNB-62	NO	NAME	DATE
2	SWIVEL CLIP	1	_____	TND-29	1	JVT	97-04-07
3	STAINLESS STEEL TUBE $\varnothing 25,4$ O.D. WALL THK 2,03 Y 855 LG	1	_____	_____	REVISED. DRG NO. WAS TN-169. DO REF: T96/001		



STORES ITEM NO
54/11680

DIMENSIONS: mm
SCALE: 1:5

  A3

DRAWING NO CEE-
TND-28

SHEET — OF —

DO REF: T80/65 GEN TOL: LIN \pm 1,0 ANG \pm 1'
DRN: T HUMAN CKD: R McMILLAN DATE: 80-02-13
ENG: _____ GA WILLIAMS for CHIEF ENG

STEADY ARM ASSEMBLY

INFRASTRUCTURE
(ELECTRICAL)



ITEM	DESCRIPTION	QTY	STORE ITEM NO.	DRG NO CEE--	AMENDMENTS		
1	CHEEK	2	---	TNB-66	NO	NAME	DATE
2	SCREW, HEX, HD, Cu,Ni,Si M10 X 6g-35 LG OR STAINLESS STEEL TO SPEC AISI GR 304	2	54/3657	---	1	JVT	97-04-07
3	WASHER, LOCK INTERNAL, TOOTH PHOSPHOR BRONZE M10 OR STAINLESS STEEL TO SPEC AISI GR 304	2	54/3688	---	REVISED. DRG NO. WAS TN-170. DO REF: T96/001		

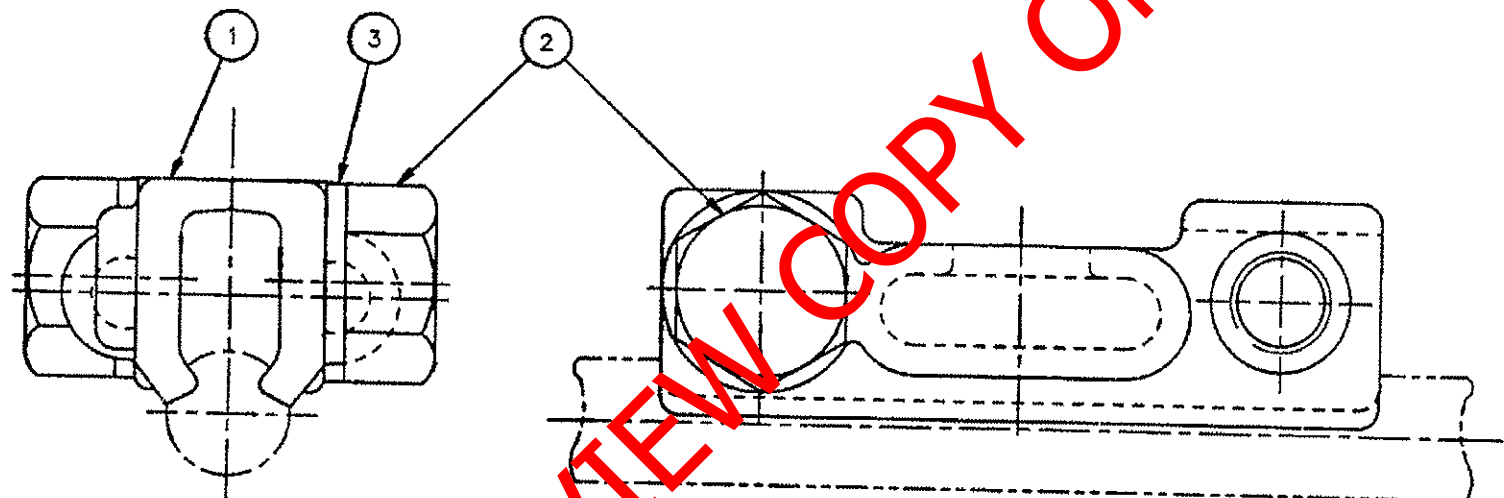

"PREVIEW COPY ONLY"

NOTES
 THE COPYRIGHT FOR THIS DESIGN IS HELD BY BRITISH INSULATED CALLENDERS CONSTRUCTION CO. LTD. COPYRIGHT © 197 SEE BICC. DRG NO SEV/123/5

STORES ITEM NO 54/11591
DIMENSIONS: mm SCALE: 1:5
A3
DRAWING NO CEE-- TND-33
SHEET -- OF --

DO REF: T80/65	GEN TOL: LIN± - ANG± -
DRN: J SCHMIDT	CKD: R McMILLAN DATE: 80-02-13
ENG: ---	GA WILLIAMS for CHIEF ENG
INFRASTRUCTURE (ELECTRICAL)	SPOORNET

ELECTRICAL CLAMP ASSEMBLY

107mm² Cu CONTACT WIRE

T0000084