

Transnet SOC Limited
T/A Transnet Capital Projects

REQUEST FOR QUOTATION



TFR RME RFQ Board
TFR RME RFQ Board
Transnet Freight Rail - RME
PROCUREMENT DEPARTMENT

Registration Number: 1990/000900/06
Vat Number : 4720103177

Attention:

Telephone Number :
Fax Number :
Vendor Number :500000

Quotation Deadline Date : 29.05.2013
Quotation Deadline Time : 16:00

REQUEST for QUOTATION

Transnet Capital Projects
RFQ Number / Date
6000160690 / 17.05.2013
Contact Person / Telephone
Troy Stevens / 021 940 1892
Return to VAX Number/EMAIL
0218100000 / TCPtendersCapeTown@Transnet.net

Item	Material	Description	RFQ Qty	UoM	Required Del date	Confirm Del date	Unit Price Excl	Total Price Excl
00010		Protection barrier	6	ea	12.06.2013			

Protection barrier
Manufacture and supply hot dipped galvanized protection barrier
as per drawing 1114651 ELEC 001 Revision O and notes

Frans Louw 0838520774

Project 1114659

Requester and Delivery Address:

Frans Louw
~~D. Toljard~~ Transnet Freight Rail (RME)
Bellville Square Bellville South Cape Town
Western Cape

Tel: 0219401818
REQUESTED BY: Frans Louw
Email: frans.louw@transnet.net

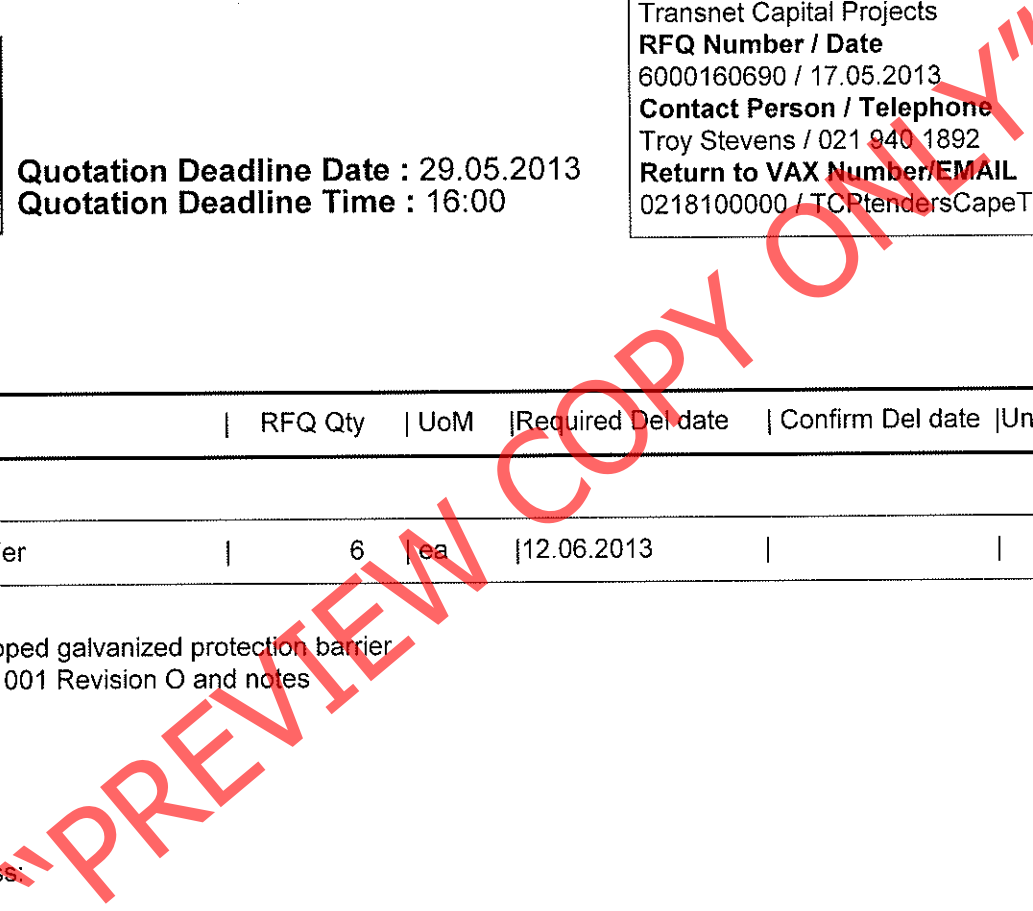



Transnet SOC Limited
 T/A Transnet Capital Projects
 TFR RME RFQ Board
 TFR RME RFQ Board
 Transnet Freight Rail - RME
 PROCUREMENT DEPARTMENT
 0000

REQUEST FOR QUOTATION

Registration Number: 1990/000900/06
 Vat Number : 4720103177

Attention:
 Telephone Number :
 Fax Number :
 Vendor Number :500000

Quotation Deadline Date : 29.05.2013
Quotation Deadline Time : 16:00

REQUEST for QUOTATION
 Transnet Capital Projects
RFQ Number / Date
 6000160690 / 17.05.2013
Contact Person / Telephone
 Troy Stevens / 021 940 1892
Return to VAX Number/EMAIL
 0218100000 / TCPtendersCapeTown@Transnet.net

Item	Material	Description	RFQ Qty	UoM	Required Del date	Confirm Del date	Unit Price Excl	Total Price Excl
------	----------	-------------	---------	-----	-------------------	------------------	-----------------	------------------

Fax: 021 9401938

If you are unable to quote for this enquiry, please submit a NO QUOTE, with a short reason, if possible, for not being able to quote.

Otherwise we look forward to receive your quote by the date and time stated.

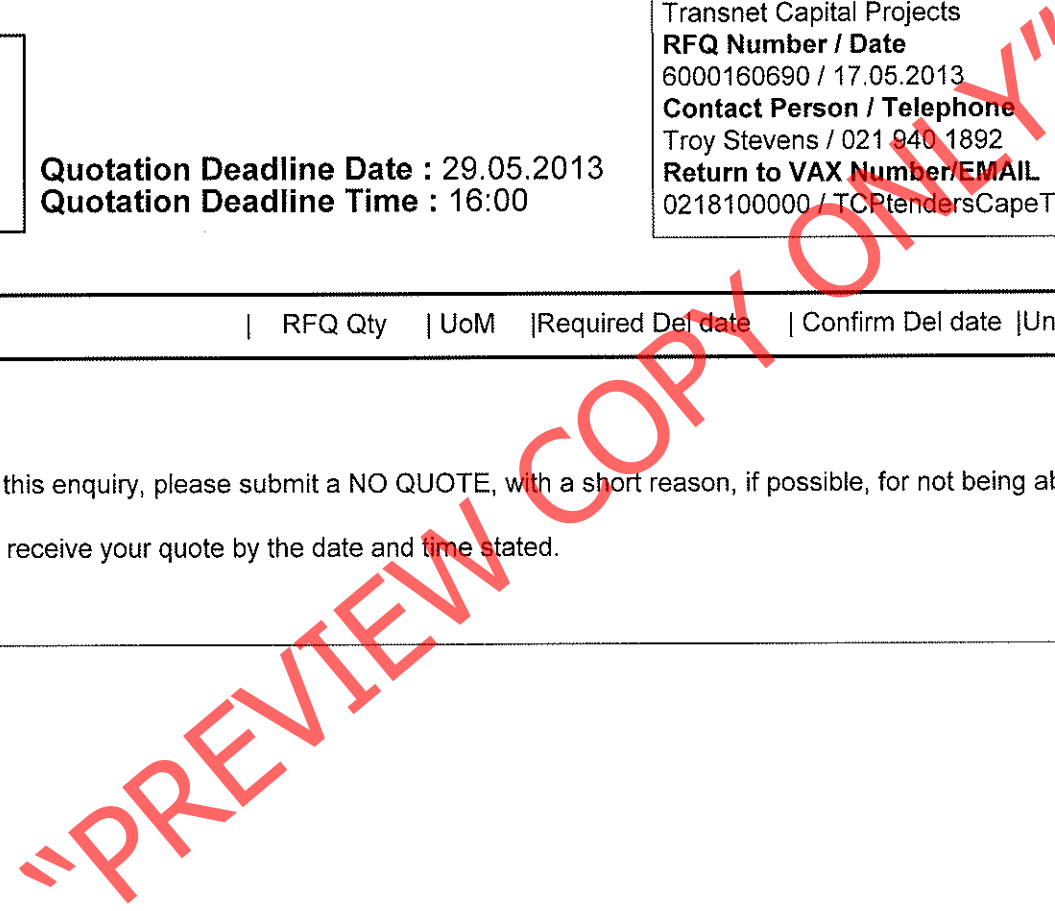

Transnet SOC Limited
 T/A Transnet Capital Projects
 TFR RME RFQ Board
 TFR RME RFQ Board
 Transnet Freight Rail - RME
 PROCUREMENT DEPARTMENT
 0000

REQUEST FOR QUOTATION

Registration Number: 1990/000900/06
 Vat Number : 4720103177

**Attention:**

Telephone Number :
 Fax Number :
 Vendor Number :500000

Quotation Deadline Date : 29.05.2013
Quotation Deadline Time : 16:00

REQUEST for QUOTATION

Transnet Capital Projects
RFQ Number / Date
 6000160690 / 17.05.2013
Contact Person / Telephone
 Troy Stevens / 021 940 1892
Return to VAX Number/EMAIL
 0218100000 / TCPtendersCapeTown@Transnet.net

Delivery Address

TFR RME Cape Town
 De Gatt Complex, Behind Propnet Ind Park, Off Modderdam Rd
 Bellville South, Cape Town
 7530

This RFQ is subject to the following conditions:

1. Price/s : The price/s quoted in SA currency and is excluding of V.A.T.
2. Delivery : The price/s quoted should include delivery cost to the delivery address stated on the RFQ
3. Returnables : A valid tax clearance certificate and BBBEE certificate from a SANAS accredited verification agency attached to quotation for all quotes above R30 000.
Please note that only the official Transnet RFQ will be accepted and all other correspondence to be attached to the original
4. Safety : To confirm to Transnet Capital Projects Health & Safety plan and specification; HAS-std-0001, copy available on request.
5. Confirmation: To confirm your participation in this tender process please sign and return this document as immediate effect prior to the quotation deadline.
6. Negotiations: The Employer may elect to negotiate the final terms of the contract/order with the preferred tenderer in accordance with Clauses F.2.17 and F.3.13 of the CIDB Standard Conditions of Tender. A copy of which is available upon request.

Signature _____

Date _____

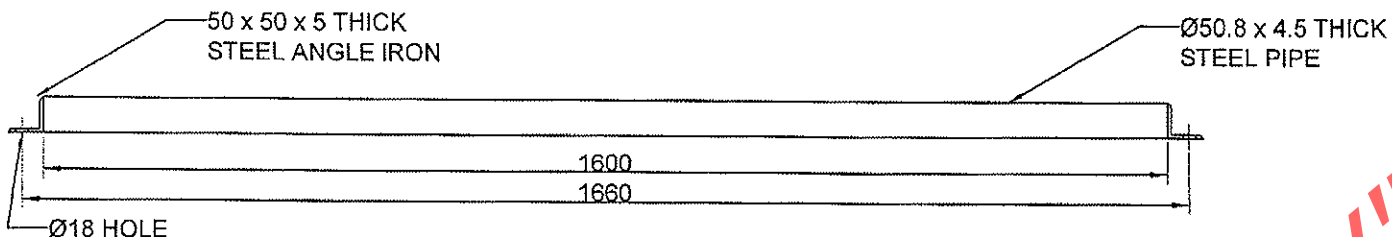

NOTE
 ALL MATERIAL MUST BE HOT
 DIPPED GALVANISED TO
 SANS 32/EN 10240 AND
 PAINTED CHEVRON BLACK
 ON YELLOW

ITEM 3

QTY: 6

M16 STEEL THREADED
 STUD WITH GALV
 WASHER & NUT

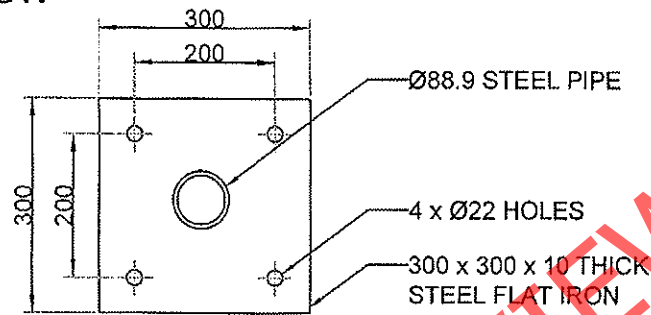

ITEM 1

QTY: 12

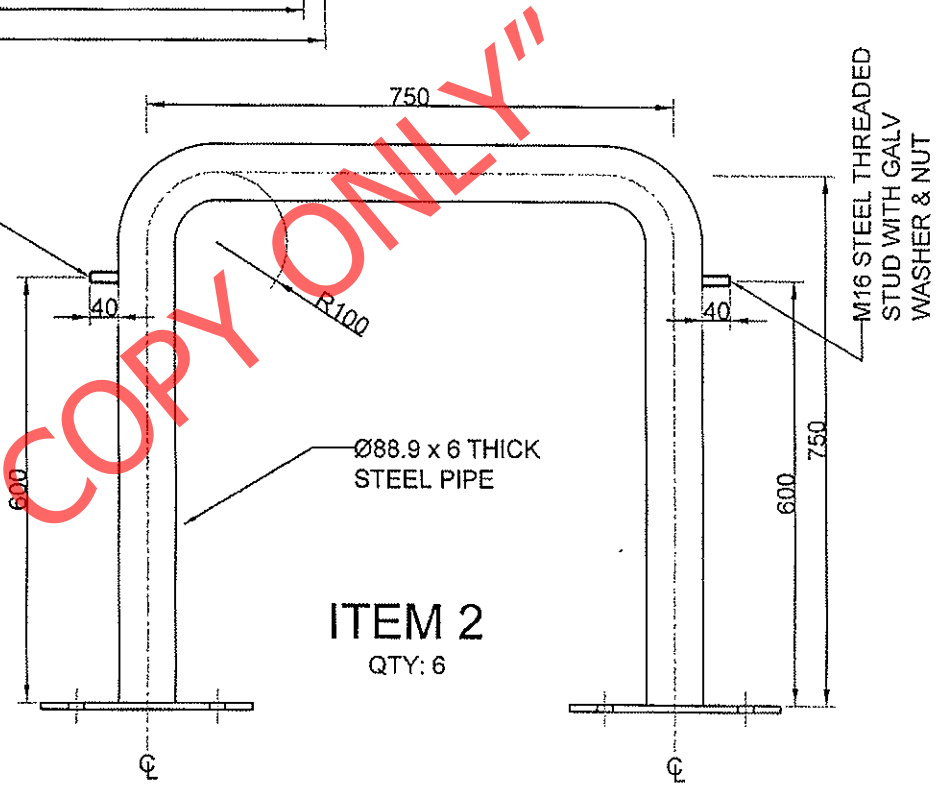

ITEM 2

QTY: 6

NO	REVISIONS	DATE	CHECKED	APPROVED
1	DWG AMENDED FOR GALVANISED STEEL.	02/05/2013		
REVISIONS				

PROJECT TITLE	DRAWING TITLE
PORT OF CAPE TOWN	PROTECTION BARRIER FOR PLINTH SUPPLY KIOSKS A-BERTH & QUAY 500 TO 503

DATE	SCALE	PAPER SIZE
24/04/2013	1:10	A4
DRAWN BY	APPROVAL	
<i>ef Louw</i>	DATE	SIGNATURE
DRAWING No.		REVISION
1114651 ELEC 001		0