



**TRANSNET**

freight rail

A Division of Transnet Limited

# TECHNOLOGY MANAGEMENT

## SPECIFICATION

### SPECIFICATION FOR GROOVED, COPPER-MAGNESIUM CONTACT WIRE, FOR ELECTRICAL TRACTION PURPOSES

Author: Chief Engineering Technician

Section: Technology Management

W.F. MANS

Approved: Senior Engineer

Section: Technology Management

L.O. BORCHARD

Authorised: Principal Engineer

Section: Technology Management

W.A. COETZEE

Date: 10 December 2009

Circulation Restricted To:

Engineering & Technology: Infrastructure Maintenance

Engineering & Technology: Infrastructure Engineering

Engineering & Technology: Technology Management

© This document as a whole is protected by copyright. The information herein is the sole property of Transnet Ltd. It may not be used, disclosed or reproduced in part or in whole in any manner whatsoever, except with the written permission of and in a manner permitted by the proprietors.

**INDEX**

SECTION	CONTENTS	PAGE
1.0	SCOPE	3
2.0	REFERENCES	3
3.0	APPENDICES	3
4.0	METHOD OF TENDERING	3
5.0	MATERIAL	3
6.0	MARKING	3
7.0	SIZE AND LENGTH	4
8.0	DRUMS AND WINDING	4
9.0	MARKING OF DRUMS	4
10.0	INFORMATION	4
11.0	TESTS	4

“PREVIEW COPY ONLY”

## 1.0 SCOPE

This specification covers Transnet's requirements for the manufacture, testing and supply of grooved, 107mm<sup>2</sup> or 161mm<sup>2</sup> copper-magnesium (CuMg0,2) contact wire.

## 2.0 REFERENCES

2.1 The following specification and drawing are referred to herein:

2.1.1 British Standards Specification:

BS EN 50149 : Railway application – Fixed installation – Electrical traction – Copper and copper alloy grooved contact wires

2.1.2 Transnet Drawing:

CEE-TW-433 : Steel Drum for Contact Wire.

## 3.0 APPENDICES

The following appendices form an integral part of this specification:

3.1 Appendix 1: Cross-sectional profile of the 107mm<sup>2</sup> or 161mm<sup>2</sup> contact wire.

3.2 Appendix 2: Special Marking for Identification Purposes.

(A) specifies the nature of the imprinting

(B) identification grooves, text size and position.

3.3 Appendix 3: Test Results of 107mm<sup>2</sup> Grooved Contact Wire.

This appendix specifies the form in which the test results for 107mm<sup>2</sup> grooved copper will be presented in order to check compliance.

3.4 Appendix 4: Test Results of 161mm<sup>2</sup> Grooved Contact Wire.

This appendix specifies the form in which the test results for 161mm<sup>2</sup> grooved copper will be presented in order to check compliance.

## 4.0 METHOD OF TENDERING

4.1 Tenderers shall indicate clause by clause compliance or non-compliance with this specification. This shall take the form of a separate document listing all the specification clause numbers indicating the individual statement of compliance or non-compliance.

4.2 A statement of non-compliance shall be motivated by the tenderer.

4.3 The test results (Appendix 3 and 4) to this specification shall be fully completed by the tenderers.

4.4 Failure to comply to clauses 4.1, 4.2 and 4.3 may preclude a tender from further consideration.

## 5.0 MATERIAL

5.1 The wire shall be made from high conductivity copper-magnesium CuMg0,2, in accordance with specification BS EN 50149. The configuration and cross-sectional areas are depicted in Appendix 1.

5.2 The wire shall comply with all the properties detailed in Appendix 3 and 4 hereof for 107mm<sup>2</sup> or 161mm<sup>2</sup> respectively.

## 6.0 MARKING

6.1 The wire shall have imprinted on the upper lobe of the wire the words TRANSNET as indicated in Appendix 2(A).

6.2 Copper-magnesium wire shall incorporate three identification grooves on the upper lobe of the wire in accordance with Appendix 2(B). These grooves will identify the copper-alloy in accordance with specification BS EN 50149.

## 7.0 SIZE AND LENGTH

- 7.1 The wire shall have a cross sectional area of 107mm<sup>2</sup> or 161mm<sup>2</sup> and shall have dimensions in accordance with Appendix 1.
- 7.2 The 107mm<sup>2</sup> wire shall be supplied in continuous lengths of 1610meter plus 2m minus 0 (zero) and the 161mm<sup>2</sup> wire shall be supplied in continuous lengths of 1830meter plus 2m minus 0 (zero).

## 8.0 DRUMS AND WINDING

- 8.1 Each drum shall be manufactured in accordance with Transnet's drawing No. CEE-TW-433 and shall have the wire tightly and evenly wound thereon.
- 8.2 The inner end of each length shall be marked at a distance of 30m from that end in such a manner as to give an observer, 6m away from the drum, an indication of the approaching end of the length when the wire is being reeled off at the rate of 60m per minute.
- 8.3 The wire shall be wound on the drum with the vertical axis of the wire at right angles to the axis of the drum and in such a manner that the contact surface of the wire shall be to the bottom when the wire is unreeled of the top of the drum. The wire shall be wound in uniform layers with turns tightly together and free from kinks and crossovers.
- 8.4 Both ends of the wire must be securely fixed to the drum flange.

## 9.0 MARKING OF DRUMS

- 9.1 Each drum shall have, clearly marked on the outer surface of one flange, the following information:
- The manufacturer's name
  - The size of the wire
  - The total length of the wire contained thereon
  - The gross mass
  - The net mass
  - Transnet's stores order number
  - A suitable sequence number for identification purposes
- 9.2 Arrows indicating the direction of un-winding, must appear clearly marked on both flanges of the drum.

## 10.0 INFORMATION

Tenderers shall submit with their tenders the following information:

- \* Maximum resistance of the wire to be supplied, ( $\Omega$ /km at 20 °C)
- \* Minimum tensile strength of the wire to be supplied (kN)
- \* Actual number and full details of the type of joints in each length of wire to be supplied

## 11.0 TESTS

- 11.1 A sample length of wire from the end of each drum shall be cut off for test purposes. When relevant, one sample length in five shall include a joint. All samples shall be tested to ensure compliance with clauses 5.2 and 7.1 hereof. Whenever samples cut off in terms of the above, includes a joint, the exact location of this joint shall be clearly and positively marked by means of non destructive chemical etching. This is required to ensure that the wire at the joints can be tested for compliance with the requirements of clause 5.2.

- 11.1.1 After removal of a sample length of wire from a drum, the actual length of wire remaining thereon, shall not be less than that called for in clause 7.2.
- 11.2 Since creep of the contact wire has to be taken into account during erection stages and afterwards during normal maintenance, tenderers must give figures indicating the initial and final creep rate that can be expected. The tensile stress for these creep rates should also be indicated.
- 11.3 Tests to confirm the compliance of the wire with the technical properties laid down in clause 5.2, shall be carried out on the sample lengths by the manufacturer as detailed in specification BS EN 50149.
- 11.4 Transnet reserves the right to witness all tests.
- 11.5 Copies of test certificates giving details of all tests results are to be handed, immediately after the tests, to Transnet, to confirm that the wire and drums meet the electrical and mechanical properties required by this specification.
- 11.5.1 The test certificates to be supplied to Transnet shall be as shown in Appendix 3 and 4.

“PREVIEW COPY ONLY”

## CROSS-SECTIONAL PROFILES

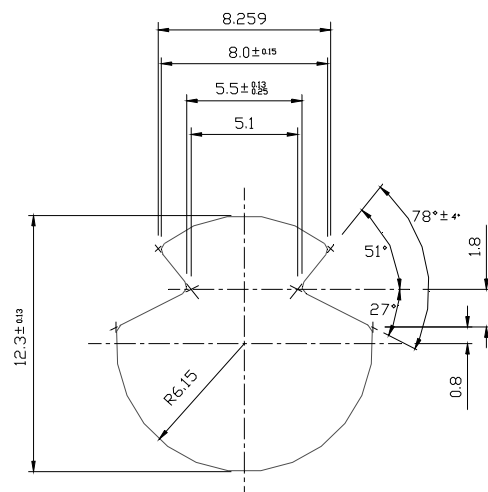
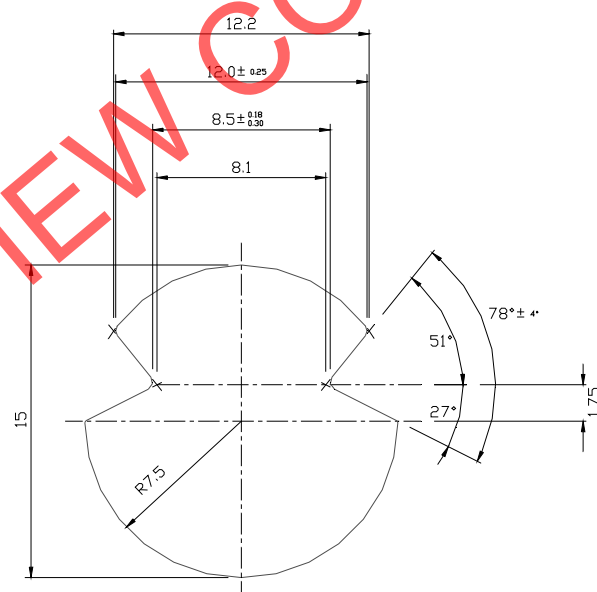
Figure 1: Cross-sectional profile of a 107mm<sup>2</sup> Contact wire.Figure 2: Cross-sectional profile of a 161mm<sup>2</sup> Contact wire.

## SPECIAL MARKING FOR IDENTIFICATION PURPOSES

(A)

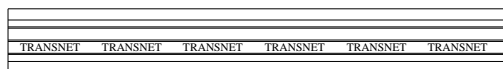
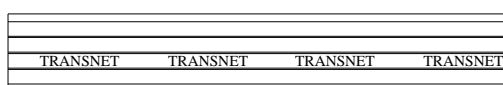
107mm<sup>2</sup> Contact wire161mm<sup>2</sup> Contact wire

In both cases (107mm<sup>2</sup> and 161mm<sup>2</sup> contact wire) the height of the text must be as indicated below.

(B)

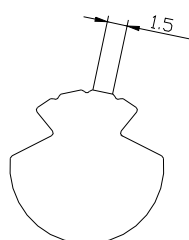
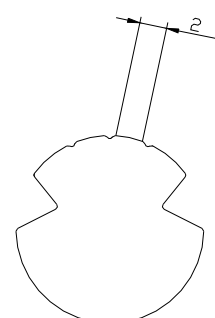
107mm<sup>2</sup>161mm<sup>2</sup>

(Illustration not to scale)

Identification grooves, Text size and position.

**TEST RESULTS OF 107mm<sup>2</sup> GROOVED CONTACT WIRE**

Customer's Name: \_\_\_\_\_

Customers Order No.: \_\_\_\_\_

Drum No.	Nominal Mass per km (kg)	Area (mm <sup>2</sup> )	Resistance per km @ 20°C	Tensile strength N/mm <sup>2</sup>	Elongation on 200 mm (%)	Twists in 250 mm	Reverse Bends	Notes
	951±3%	107	0.268 max	500 min	3.0 min	5 min	6 min	

“PREVIEW COPY ONLY”

Signed: Quality Inspector: \_\_\_\_\_ Date: \_\_\_\_\_

Testing Authority: \_\_\_\_\_ Date: \_\_\_\_\_



**TEST RESULTS OF 161mm<sup>2</sup> GROOVED CONTACT WIRE**

Customer's Name: \_\_\_\_\_

Customers Order No.: \_\_\_\_\_

Drum No.	Nominal Mass per km (kg)	Area (mm <sup>2</sup> )	Resistance per km @ 20°C	Tensile strength N/mm <sup>2</sup>	Elongation on 200 mm (%)	Twists in 250 mm	Reverse Bends	Notes
	1432 ±3%	161	0.138 max	420 min	3.0 min	5 min	6 min	

PREVIEW COPY ONLY

Signed: Quality Inspector: \_\_\_\_\_ Date: \_\_\_\_\_

Testing Authority: \_\_\_\_\_ Date: \_\_\_\_\_