

TRANSNET



freight rail

A Division of Transnet SOC Limited Registration number 1990/00900/30

REQUEST FOR QUOTATION

KBY/52946

KBC_14183

Senior Buyer
Supply Chain Services
TRANSNET FREIGHT RAIL
Austen Street
KIMBERLEY
8301



Transnet Freight Rail, a division of

TRANSNET SOC LTD

Registration Number 1990/000900/30

[hereinafter referred to as **Transnet**]

REQUEST FOR QUOTATION [RFQ] No KBY/52946

**FOR THE PROVISION OF: REPLACE FENCING BETWEEN EMMAUS AND
PETRUSBURG STATIONS (±19.89KM) FOR A
PERIOD OF 3 MONTHS.**

FOR DELIVERY TO: THE INFRA MANAGER KIMBERLEY

ISSUE DATE: 19 MAY 2014

CLOSING DATE: 10 JUNE 2014

CLOSING TIME: 10:00

SITE MEETING: 03 JUNE 2014 AT 10:00

**VENUE: IN THE BOARDROOM OF THE REAL ESTATE MANAGEMENT
BUILDING, AUSTEN STREET, BEACONSFIELD**

Section 1
NOTICE TO BIDDERS

Quotations which must be completed as indicated in Section 2 of this RFQ are to be submitted as follows:

METHOD: Tender Box
CLOSING VENUE: Transnet Freight Rail, Property Management Building, Office no. 2, Austen Street, Beaconsfield

1 Responses to RFQ

Responses to this RFQ [**Quotations**] must not include documents or reference relating to any other quotation or proposal. Any additional conditions must be embodied in an accompanying letter.

2 Broad-Based Black Economic Empowerment [B-BBEE]

Transnet fully endorses and supports the Government's Broad-Based Black Economic Empowerment Programme and it would therefore prefer to do business with local business enterprises who share these same values. Transnet will accordingly allow a "preference" to companies who provide a valid B-BBEE Verification Certificate. All procurement transactions will be evaluated accordingly.

2.1 B-BBEE Scorecard and Rating

As prescribed in terms of the Preferential Procurement Policy Framework Act (PPPFA), Act 5 of 2000 and its Regulations, Respondents are to note that the following preference point system is applicable to all bids:

- the 80/20 system for requirements with a Rand value of up to R1 000 000.00 (all applicable taxes included).
- Bidders are to note that if the 80/20 preference point system is stipulated in this RFQ and all Bids received exceed R1 000 000.00, the RFQ must be cancelled.

The value of this bid is estimated to be below R1 000 000.00 (all applicable taxes included) and therefore the **80/20** system shall be applicable.

When Transnet invites prospective suppliers to submit Proposals for its various expenditure programmes, it requires Respondents to have their B-BBEE status verified in compliance with the Codes of Good Practice issued in terms of the Broad Based Black Economic Empowerment Act No. 53 of 2003.

The Department of Trade and Industry recently revised the Codes of Good Practice on 11 October 2013 [Government Gazette No. 36928]. The Revised Codes will replace the Black Economic Empowerment Codes of Good Practice issued on 9 February 2007. The Revised Codes provide for a one year transitional period starting 11 October 2013. During the transitional period, companies may elect to be measured in terms of the Revised Codes or the 2007 version of the Codes. After the first year of the implementation of the Revised Codes, B-BBEE compliance will be measured in terms of the Revised Codes without any discretion. Companies which are governed by Sector-specific Codes will be measured in terms of those Sector Codes.

2

Respondent's Signature

Date & Company Stamp

As such, Transnet will accept B-BBEE certificates issued based on the Revised Codes. Transnet will also continue to accept B-BBEE certificates issued in terms of the 2007 version of the Codes provided it was issued before 10 October 2014. Thereafter, Transnet will only accept B-BBEE certificates issued based on the Revised Codes.

Respondents are required to complete Annexure A [the B-BBEE Preference Point Claim Form] and submit it together with proof of their B-BBEE Status as stipulated in the Claim Form in order to obtain preference points for their B-BBEE status.

Note: Failure to submit a valid and original B-BBEE certificate or a certified copy thereof at the Closing Date of this RFQ will result in a score of zero being allocated for B-BBEE.

[Refer clause 19 below for Returnable Documents required]

3 Communication

a) Respondents are warned that a response will be liable for disqualification should any attempt be made by a Respondent either directly or indirectly to canvass any officer(s) or employee of Transnet in respect of this RFQ between the closing date and the date of the award of the business.

b) A Respondent may, however, before the closing date and time, direct any written enquiries relating to the RFQ to the following Transnet employee:

Name: Herman Conradie Email: Herman.Conradie@transnet.net

c) Respondents may also, at any time after the closing date of the RFQ, communicate with Maggie Pain (Admin Support) on any matter relating to its RFQ response:

Telephone: 053 838 3341 Email: Maggie.Pain@transnet.net

4 Tax Clearance

The Respondent's original and valid Tax Clearance Certificate must accompany the Quotation. Note that no business shall be awarded to any Respondent whose tax matters have not been declared by SARS to be in order.

5 VAT Registration

The valid VAT registration number must be stated here: _____ *[if applicable]*.

6 Legal Compliance

The successful Respondent shall be in full and complete compliance with any and all applicable national and local laws and regulations.

7 Changes to Quotations

Changes by the Respondent to its submission will not be considered after the closing date and time.

8 Pricing

All prices must be quoted in South African Rand on a fixed price basis, excluding VAT.

9 Prices Subject to Confirmation

Prices quoted which are subject to confirmation will not be considered.

10 Negotiations

Transnet reserves the right to undertake post-tender negotiations with selected Respondents or any number of short-listed Respondents.

11 Binding Offer

Any Quotation furnished pursuant to this Request shall be deemed to be an offer. Any exceptions to this statement must be clearly and specifically indicated.

12 Disclaimers

Transnet is not committed to any course of action as a result of its issuance of this RFQ and/or its receipt of a Quotation in response to it. Please note that Transnet reserves the right to:

- modify the RFQ's goods / service(s) and request Respondents to re-bid on any changes;
- reject any Quotation which does not conform to instructions and specifications which are detailed herein;
- disqualify Quotations submitted after the stated submission deadline;
- not necessarily accept the lowest priced Quotation;
- reject all Quotations, if it so decides;
- place an order in connection with this Quotation at any time after the RFQ's closing date;
- award only a portion of the proposed goods / service/s which are reflected in the scope of this RFQ;
- split the award of the order/s between more than one Supplier/Service Provider; or
- make no award at all.

Transnet reserves the right to award business to the highest scoring bidder/s unless objective criteria justify the award to another bidder.

13 Transnet's supplier integrity pact

Transnet's Integrity Pact requires a commitment from suppliers and Transnet that they will not engage in any corrupt and fraudulent practices, anti-competitive practices; and act in bad faith towards each other. The Integrity Pact also serves to communicate Transnet's Gift Policy as well as the remedies available to Transnet where a Respondent contravenes any provision of the Integrity Pact.

Respondents are required to familiarise themselves with the contents of the Integrity Pact which is available on the Transnet Internet site [www.transnet.net/Tenders/Pages/default.aspx] or on request. Furthermore, Respondents are required to certify that they have acquainted themselves with all the documentation comprising the Transnet Integrity Pact and that they fully comply with all the terms and conditions stipulated in the Transnet Supplier Integrity Pact as follows:

YES	
------------	--

NO	
-----------	--

Respondent's Signature

4

Date & Company Stamp

Should a Respondent need to declare previous transgressions or a serious breach of law in the preceding 5 years as required by Annexure A to the Integrity Pact, such declaration must accompany the Respondent's bid submission.

14 Evaluation Criteria

Transnet will utilise the following criteria [not necessarily in this order] in choosing a Supplier/Service Provider, if so required:

Criterion/Criteria	Explanation
Administrative responsiveness	Completeness of response and returnable documents
Substantive responsiveness	Prequalification criteria, if any, must be met and whether the Bid materially complies with the scope and/or specification given.
Final weighted evaluation based on 80/20 preference point system	<ul style="list-style-type: none"> Pricing and price basis [firm] - whilst not the sole factor for consideration, competitive pricing and overall level of unconditional discounts¹ will be critical B-BBEE status of company - Preference points will be awarded to a bidder for attaining the B-BBEE status level of contribution in accordance with the table indicated in Annexure A.

15 Validity Period

Transnet desires a validity period of 30 [thirty] days from the closing date of this RFQ.

This RFQ is valid until _____.

16 Banking Details

BANK: _____

BRANCH NAME / CODE: _____

ACCOUNT HOLDER: _____

ACCOUNT NUMBER: _____

17 Company Registration

Registration number of company / C.C. _____

Registered name of company / C.C. _____

18 Disclosure of Prices Quoted

Respondents must indicate here whether Transnet may disclose their quoted prices and conditions to other Respondents:

YES NO

¹ Only unconditional discounts will be taken into account during evaluation. A discount which has been offered conditionally will, despite not being taken into account for evaluation purposes, be implemented when payment is effected.

19 Returnable Documents

Returnable Documents means all the documents, Sections and Annexures, as listed in the tables below.

- a) Respondents are required to submit with their Quotations the **Returnable Documents**, as detailed below.

Failure to provide all these Returnable Documents at the Closing Date and time of this RFQ may result in a Respondent's disqualification. Respondents are therefore urged to ensure that all these Documents are returned with their Quotations.

All Sections, as indicated in the footer of each page, must be signed, stamped and dated by the Respondent. Please confirm submission of these Returnable Documents by so indicating [Yes or No] in the table below:

Returnable Documents	Submitted [Yes or No]
SECTION 1 : Notice to Bidders	
<ul style="list-style-type: none"> - Valid and original B-BBEE Verification Certificate or certified copy thereof [Large Enterprises and QSEs] Note: failure to provide a valid B-BBEE Verification Certificate at the closing date and time of the RFQ will result in an automatic score of zero for preference 	
<ul style="list-style-type: none"> - Valid and original B-BBEE certificate/sworn affidavit or certified copy thereof from auditor, accounting officer or SANAS accredited Verification Agency [EMEs] Note: failure to provide a valid B-BBEE Verification Certificate at the closing date and time of the RFQ will result in an automatic score of zero being allocated for preference 	
<ul style="list-style-type: none"> - In the case of Joint Ventures, a copy of the Joint Venture Agreement or written confirmation of the intention to enter into a Joint Venture Agreement 	
<ul style="list-style-type: none"> - Original valid Tax Clearance Certificate [Consortia / Joint Ventures must submit a separate Tax Clearance Certificate for each party] 	
SECTION 2 : Quotation Form	
SECTION 3: Vendor Application Form <ul style="list-style-type: none"> • Original cancelled cheque or bank verification of banking details • Certified copies of IDs of shareholder/directors/members [as applicable] • Certified copies of the relevant company registration documents from Companies and Intellectual Property Commission (CIPC) • Certified copies of the company's shareholding/director's portfolio • Entity's letterhead • Certified copy of VAT Registration Certificate [RSA entities only] • Certified copy of valid Company Registration Certificate [if applicable] 	
ANNEXURE A – B-BBEE Preference Points Claim Form	
ANNEXURE B – Project Specifications	

b

Respondent's Signature

Date & Company Stamp

Section 2
QUOTATION FORM

I/We _____
hereby offer to supply the goods/services at the prices quoted in the Price Schedule below, in accordance with the conditions related thereto.

I/We agree to be bound by those terms and conditions in:

- the Standard Terms and Conditions for the Supply of Goods or Services to Transnet [available on request]; and
- any other standard or special conditions mentioned and/or embodied in this Request for Quotation.

I/We accept that unless Transnet should otherwise decide and so inform me/us, this Quotation [and, if any, its covering letter and any subsequent exchange of correspondence], together with Transnet's acceptance thereof shall constitute a binding contract between Transnet and me/us.

I/We further agree that if, after I/we have been notified of the acceptance of my/our Quotation, I/we fail to deliver the said goods/service/s within the delivery lead-time quoted, Transnet may, without prejudice to any other legal remedy which it may have, cancel the order and recover from me/us any expenses incurred by Transnet in calling for Quotations afresh and/or having to accept any less favourable offer.

"PREVIEW ONLY COPY"

SERVICE FEES AND COST

I/We quote as follows for the service required excluding VAT:

		unit per	QUANTITY	UNIT RATE	AMOUNT	
					Rand	Cents
1	Loading of material at Beaconsfield Depot to site	kilometre	86			
2	General travelling to site/back (bakkie)(logsheets)	kilometre				
3	Remove old fence	metres	12575			
4	Roll-up old fence into rolls	metres	12575			
5	Clean 1 metre on both sides of fence, remove all bushes etc.	metres	12575			
6	Dig holes for poles 450 mm deep x 400mm diameter	metres	126			
7	Concrete 101mm anchor poles for gate @ 4.2 m (stand 7 days)	each	2			
8	Concrete 50mm struts for anchor poles (stand 7 days)	each	12			
9	Concrete 75 mm anchor poles @ 60 metres crs (stand 7days)	each	92			
10	Concrete 50mm struts at every 6 th pole (stand 7days)	each	92			
11	Span fence barbed wire (new =3 wires)	metres	37725			
12	Span Steel Wire (new=3 wires)	metres	37725			
13	Install Y Standards @ 15 Metres apart & tie to specifications	each	271			
14	Install Droppers @ 2,5 metres apart & tie to specifications	each	1815			
15	Install gate as specified	each	2			
16	Span Veldspan on both sides	rolls	126			
17	Removing of steel steepers from fence	each	2389			
18	Remove old material to Infra Depot , Beaconsfield	kilometres	86			
19	Remove access material to Infra Depot , Beaconsfield	kilometres	86			
20	Paint of poles (complete)	each	94			
21	Paint of y standards & droppers (200mm from top)	each	2086			
				GROSS TOTAL	R	
				VAT (14%)	R	
				AMOUNT DUE	R	

"PREVIEW ONLY - COPY"

NAME OF FIRM CONTRACTOR

Total Tender Price in Words:

Notes to Pricing:

- a) All Prices must be quoted in South African Rand, exclusive of VAT
- b) To facilitate like-for-like comparison bidders must submit pricing strictly in accordance with this price schedule and not utilise a different format. Deviation from this pricing schedule could result in a bid being disqualified.
- c) Please note that should you have offered a discounted price(s), Transnet will only consider such price discount(s) in the final evaluation stage if offered on an unconditional basis.

Respondent's Signature

Date & Company Stamp

Section 3

Transnet Supplier Declaration/Application

The Financial Director or Company Secretary

Transnet Vendor Management has received a request to load your company on to the Transnet vendor database. Please furnish us with the following to enable us to process this request:

1. Complete the "Supplier Declaration Form" (SDF) on page 2 of this letter
2. **Original** cancelled cheque **OR** letter from the bank verifying banking details (**with bank stamp**)
3. **Certified** copy of Identity document of Shareholders/Directors/Members (where applicable)
4. **Certified** copy of certificate of incorporation, CM29 / CM9 (name change)
5. **Certified** copy of share Certificates of Shareholders, CK1 / CK2 (if CC)
6. A letter with the company's letterhead confirming physical and postal addresses
7. **Original** or **certified** copy of SARS Tax Clearance certificate and Vat registration certificate
8. A signed letter from the Auditor / Accountant confirming most recent annual turnover and percentage black ownership in the company **AND/OR** BBBEE certificate and detailed scorecard from an accredited rating agency (SANAS member).

NB: **Failure to submit the above documentation will delay the vendor creation process.**
 • Where applicable, the respective Transnet business unit processing your application may request further information from you. E.g. proof of an existence of a Service/Business contract between your business and the respective Transnet business unit etc.

IMPORTANT NOTES:

- a) **If your annual turnover is less than R5 million**, then in terms of the DTI codes, you are classified as an Exempted Micro Enterprise (EME). If your company is classified as an EME, please include in your submission, a signed letter from your Auditor / Accountant confirming your company's most recent annual turnover is less than R5 million and percentage of black ownership and black female ownership in the company **AND/OR** BBBEE certificate and detailed scorecard from an accredited rating agency (e.g. permanent SANAS Member), should you feel you will be able to attain a better BBBEE score.
- b) **If your annual turnover is between R5 million and R35million**, then in terms of the DTI codes, you are classified as a Qualifying Small Enterprise (QSE) and you claim a specific BBBEE level based on any 4 of the 7 elements of the BBBEE score-card, please include your BEE certificate in your submission as confirmation of your status.
NB: BBBEE certificate and detailed scorecard should be obtained from an accredited rating agency (e.g. permanent SANAS Member).
- c) **If your annual turnover is in excess of R35million**, then in terms of the DTI codes, you are classified as a Large Enterprise and you claim a specific BEE level based on all seven elements of the BBBEE generic score-card. Please include your BEE certificate in your submission as confirmation of your status.
NB: BBBEE certificate and detailed scorecard should be obtained from an accredited rating agency (permanent SANAS Member).
- d) **To avoid PAYE tax being automatically deducted from any invoices received from you**, you must also contact the Transnet person who lodged this request on your behalf, so as to be correctly classified in terms of Tax legislation.
- e) Unfortunately, **No payments can be made to a vendor** until the vendor has been registered, and no vendor can be registered until the vendor application form, together with its supporting documentation, has been received and processed.
- f) **Please return the completed Supplier Declaration Form (SDF) together with the required supporting documents mentioned above to the Transnet Official who is intending to procure your company's services/products in order that he/she should complete and Internal Transnet Departmental Questionnaire before referring the matter to the appropriate Transnet Vendor Master Office.**

Regards,

9

Respondent's Signature

Date & Company Stamp

Supplier Declaration Form

Company Trading Name							
Company Registered Name							
Company Registration Number Or ID Number If A Sole Proprietor							
Form of entity	CC	Trust	Pty Ltd	Limited	Partnership	Sole Proprietor	
VAT number (if registered)							
Company Telephone Number							
Company Fax Number							
Company E-Mail Address							
Company Website Address							
Bank Name					Bank Account Number		
Postal Address						Code	
Physical Address						Code	
Contact Person							
Designation							
Telephone							
Email							
Annual Turnover Range (Last Financial Year)		< R5 Million		R5-35 million		> R35 million	
Does Your Company Provide		Products		Services		Both	
Area Of Delivery		National		Provincial		Local	
Is Your Company A Public Or Private Entity				Public		Private	
Does Your Company Have A Tax Directive Or IRP30 Certificate				Yes		No	
Main Product Or Service Supplied (E.G.: Stationery/Consulting)							
BEE Ownership Details							
% Black Ownership		% Black women ownership		% Disabled person/s ownership			
Does your company have a BEE certificate		Yes		No			
What is your broad based BEE status (Level 1 to 9 / Unknown)							
How many personnel does the firm employ		Permanent		Part time			
Transnet Contact Person							
Contact number							
Transnet operating division							
Duly Authorised To Sign For And On Behalf Of Firm / Organisation							
Name				Designation			
Signature				Date			
Stamp And Signature Of Commissioner Of Oath							
Name				Date			
Signature				Telephone No.			

**RFQ KBY/52946 FOR THE SUPPLY OF:
REPLACE FENCING BETWEEN EMMAUS AND PETRUSBURG STATIONS
FOR A PERIOD OF 3 MONTHS**

ANNEXURE A: B-BBEE PREFERENCE POINTS CLAIM FORM

This preference form contains general information and serves as a claim for preference points for Broad-Based Black Economic Empowerment [B-BBEE] Status Level of Contribution.

1. INTRODUCTION

- 1.1 A total of 20 preference points shall be awarded for B-BBEE Status Level of Contribution.
- 1.2 Failure on the part of a Bidder to fill in and/or to sign this form and submit a B-BBEE Verification Certificate from a Verification Agency accredited by the South African Accreditation System [SANAS] or a Registered Auditor approved by the Independent Regulatory Board of Auditors [IRBA] or an Accounting Officer as contemplated in the Close Corporation Act [CCA] together with the bid will be interpreted to mean that preference points for B-BBEE Status Level of Contribution are not claimed.
- 1.3 Transnet reserves the right to require of a Bidder, either before a Bid is adjudicated or at any time subsequently, to substantiate any claim in regard to preferences, in any manner required by Transnet.

2. GENERAL DEFINITIONS

- 2.1 "all applicable taxes" include value-added tax, pay as you earn, income tax, unemployment insurance fund contributions and skills development levies;
- 2.2 "B-BBEE" means broad-based black economic empowerment as defined in section 1 of the Broad-Based Black Economic Empowerment Act;
- 2.3 "B-BBEE status of contributor" means the B-BBEE status received by a measured entity based on its overall performance using the relevant scorecard contained in the Codes of Good Practice on Black Economic Empowerment, issued in terms of section 9(1) of the Broad-Based Black Economic Empowerment Act;
- 2.4 "Bid" means a written offer in a prescribed or stipulated form in response to an invitation by Transnet for the provision of goods, works or services;
- 2.5 "Broad-Based Black Economic Empowerment Act" means the Broad-Based Black Economic Empowerment Act, 2003 [Act No. 53 of 2003];
- 2.6 "comparative price" means the price after the factors of a non-firm price and all unconditional discounts that can be utilised have been taken into consideration;
- 2.7 "consortium or joint venture" means an association of persons for the purpose of combining their expertise, property, capital, efforts, skills and knowledge in an activity for the execution of a contract;

- 2.8 **"contract"** means the agreement that results from the acceptance of a bid by Transnet;
- 2.9 **"EME"** means any enterprise with an annual total revenue of R5 [five] million or less as per the 2007 version of the B-BBEE Codes of Good Practice and means any enterprise with an annual total revenue of R10 [ten] million or less as per the Revised Codes of Good Practice issued on 11 October 2013 in terms of Government Gazette No. 36928;
- 2.10 **"firm price"** means the price that is only subject to adjustments in accordance with the actual increase or decrease resulting from the change, imposition, or abolition of customs and excise duty and any other duty, levy, or tax, which, in terms of the law or regulation, is binding on the contractor and demonstrably has an influence on the price of any supplies, or the rendering costs of any service, for the execution of the contract;
- 2.11 **"functionality"** means the measurement according to predetermined norms, as set out in the bid documents, of a service or commodity that is designed to be practical and useful, working or operating, taking into account, among other factors, the quality, reliability, viability and durability of a service and the technical capacity and ability of a bidder;
- 2.12 **"non-firm prices"** means all prices other than "firm" prices;
- 2.13 **"person"** includes reference to a juristic person;
- 2.14 **"QSE"** means any enterprise with an annual total revenue between R5 [five] million and R35 [thirty five] million as per the 2007 version of the B-BBEE Codes of Good Practice and means any enterprise with an annual total revenue of between R10 [ten] million and R50 [fifty] million as per the Revised Codes of Good Practice issued on 11 October 2013 in terms of Government Gazette No. 36928
- 2.15 **"rand value"** means the total estimated value of a contract in South African currency, calculated at the time of bid invitations, and includes all applicable taxes and excise duties;
- 2.16 **"subcontract"** means the primary contractor's assigning or leasing or making out work to, or employing another person to support such primary contractor in the execution of part of a project in terms of the contract;
- 2.17 **"total revenue"** bears the same meaning assigned to this expression in the Codes of Good Practice on Black Economic Empowerment, issued in terms of section 9(1) of the Broad-Based Black Empowerment Act and promulgated in the Government Gazette on 9 February 2007;
- 2.18 **"trust"** means the arrangement through which the property of one person is made over or bequeathed to a trustee to administer such property for the benefit of another person; and
- 2.19 **"trustee"** means any person, including the founder of a trust, to whom property is bequeathed in order for such property to be administered for the benefit of another person.

3. ADJUDICATION USING A POINT SYSTEM

- 3.1 The Bidder obtaining the highest number of total points for the evaluation criteria as enumerated in Section 2 of the RFP will be awarded the contract, unless objective criteria justifies the award to another bidder.
- 3.2 Preference points shall be calculated after prices have been brought to a comparative basis taking into account all factors of non-firm prices and all unconditional discounts.

- 3.3 Points scored will be rounded off to 2 [two] decimal places.
- 3.4 In the event of equal points scored, the Bid will be awarded to the Bidder scoring the highest number of preference points for B-BBEE.
- 3.5 However, when functionality is part of the evaluation process and two or more Bids have scored equal points including equal preference points for B-BBEE, the successful Bid will be the one scoring the highest score for functionality.
- 3.6 Should two or more Bids be equal in all respect, the award shall be decided by the drawing of lots.

"PREVIEW ONLY COPY"

4. POINTS AWARDED FOR B-BBEE STATUS LEVEL OF CONTRIBUTION

- 4.1 In terms of the Preferential Procurement Regulations, 2011, preference points shall be awarded to a Bidder for attaining the B-BBEE status level of contribution in accordance with the table below:

B-BBEE Status Level of Contributor	Number of Points [Maximum 20]
1	20
2	18
3	16
4	12
5	8
6	6
7	4
8	2
Non-compliant contributor	0

- 4.2 Bidders who qualify as EMEs in terms of the 2007 version of the Codes of Good Practice must submit a certificate issued by an Accounting Officer as contemplated in the CCA or a Verification Agency accredited by SANAS or a Registered Auditor. Registered auditors do not need to meet the prerequisite for IRBA's approval for the purpose of conducting verification and issuing EME's with B-BBEE Status Level Certificates.
- 4.3 Bidders who qualify as EMEs in terms of the Revised Codes of Good Practice issued on 11 October 2013 in terms of Government Gazette No. 36928 are only required to obtain a sworn affidavit on an annual basis confirming that the entity has an Annual Total Revenue of R10 million or less and the entity's Level of Black ownership.
- 4.4 In terms of the 2007 version of the Codes of Good Practice, Bidders other than EMEs must submit their original and valid B-BBEE status level verification certificate or a certified copy thereof, substantiating their B-BBEE rating issued by a Registered Auditor approved by IRBA or a Verification Agency accredited by SANAS.
- 4.5 In terms of the Revised Codes of Good Practice issued on 11 October 2013 in terms of Government Gazette No. 36928, Bidders who qualify as QSEs are only required to obtain a sworn affidavit on an annual basis confirming that the entity has an Annual Total Revenue of R50 million or less and the entity's Level of Black ownership. Large enterprises must submit their original and valid B-BBEE status level verification certificate or a certified copy thereof, substantiating their B-BBEE rating issued by a Registered Auditor approved by IRBA or a Verification Agency accredited by SANAS.
- 4.6 A trust, consortium or joint venture will qualify for points for its B-BBEE status level as a legal entity, provided that the entity submits its B-BBEE status level certificate.
- 4.7 A trust, consortium or joint venture will qualify for points for their B-BBEE status level as an unincorporated entity, provided that the entity submits their consolidated B-BBEE scorecard as if they were a group structure and that such a consolidated B-BBEE scorecard is prepared for every separate bid.
- 4.8 Tertiary institutions and public entities will be required to submit their B-BBEE status level

certificates in terms of the specialised scorecard contained in the B-BBEE Codes of Good Practice.

- 4.9 A person will not be awarded points for B-BBEE status level if it is indicated in the Bid documents that such a Bidder intends subcontracting more than 25% [twenty-five per cent] of the value of the contract to any other enterprise that does not qualify for at least the same number of points that such a Bidder qualifies for, unless the intended subcontractor is an EME that has the capability and ability to execute the subcontract.
- 4.10 A person awarded a contract may not subcontract more than 25% [twenty-five per cent] of the value of the contract to any other enterprise that does not have an equal or higher B-BBEE status level than the person concerned, unless the contract is subcontracted to an EME that has the capability and ability to execute the subcontract.
- 4.11 Bidders are to note that in terms of paragraph 2.6 of Statement 000 of the Revised Codes of Good Practice issued on 11 October 2013 in terms of Government Gazette No. 36928, any representation made by an entity about its B-BBEE compliance must be supported by suitable evidence or documentation. As such, Transnet reserves the right to request such evidence or documentation from Bidders in order to verify any B-BBEE recognition claimed.

5. B-BBEE STATUS AND SUBCONTRACTING

5.1 Bidders who claim points in respect of B-BBEE Status Level of Contribution must complete the following:

B-BBEE Status Level of Contributor _____ = _____ [maximum of 20 points]

Note: Points claimed in respect of this paragraph 5.1 must be in accordance with the table reflected in paragraph 4.1 above and must be substantiated by means of a B-BBEE certificate issued by a Verification Agency accredited by SANAS or a Registered Auditor approved by IRBA or a sworn affidavit in the case of an EME or QSE.

5.2 Subcontracting:

Will any portion of the contract be subcontracted? YES/NO [delete which is not applicable]

If YES, indicate:

- (i) What percentage of the contract will be subcontracted?%
- (ii) The name of the subcontractor
- (iii) The B-BBEE status level of the subcontractor
- (iv) Is the subcontractor an EME? YES/NO

5.3 Declaration with regard to Company/Firm

- (i) Name of Company/Firm.....
- (ii) VAT registration number.....
- (iii) Company registration number.....
- (iv) Type of Company / Firm [TICK APPLICABLE BOX]

- Partnership/Joint Venture/Consortium
- One person business/sole propriety
- Close Corporations
- Company (Pty) Ltd

(v) Describe Principal Business Activities

.....
.....
.....

(vi) Company Classification [TICK APPLICABLE BOX]

Manufacturer

Supplier

Professional Service Provider

Other Service Providers, e.g Transporter, etc

(vii) Total number of years the company/firm has been in business.....

BID DECLARATION

I/we, the undersigned, who warrants that he/she is duly authorised to do so on behalf of the company/firm, certify that points claimed, based on the B-BBEE status level of contribution indicated in paragraph 4 above, qualifies the company/firm for the preference(s) shown and I / we acknowledge that:

- (i) The information furnished is true and correct.
- (ii) In the event of a contract being awarded as a result of points claimed as shown in paragraph 6 above, the contractor may be required to furnish documentary proof to the satisfaction of Transnet that the claims are correct.
- (iii) If the B-BBEE status level of contribution has been claimed or obtained on a fraudulent basis or any of the conditions of contract have not been fulfilled, Transnet may, in addition to any other remedy it may have:
 - (a) disqualify the person from the bidding process;
 - (b) recover costs, losses or damages it has incurred or suffered as a result of that person's conduct;
 - (c) cancel the contract and claim any damages which it has suffered as a result of having to make less favourable arrangements due to such cancellation;
 - (d) restrict the Bidder or contractor, its shareholders and directors, and/or associated entities, or only the shareholders and directors who acted in a fraudulent manner, from obtaining business from Transnet for a period not exceeding 10 years, after the *audi alteram partem* [hear the other side] rule has been applied; and/or
 - (e) forward the matter for criminal prosecution.

WITNESSES:

1.

2.

SIGNATURE OF BIDDER

DATE:.....

COMPANY NAME:

ADDRESS:.....

TRANSNET LIMITED

(REGISTRATION NO 1990/000900/06)

TRANSNET



freight rail

BEACONSFIED DEPOT

CONTRACT

REPLACE FENCING BETWEEN EMMAUS AND PETRUSBURG BLOEMFONTEIN – BEACONSFIELD

Part A: GENERAL

This **Contract** is a fencing contract which involves removing of existing fence and replacing with a new fence on Transnet reserves.

1. 83.697 kilometres to 77.423 kilometres LEFT SIDE.
2. 83.697 kilometres to 77.423 kilometres RIGHT SIDE
3. 93.795 kilometres to 86.459 kilometres RIGHT SIDE

TOTAL OF 19.885 kilometre of fencing between Emmaus and Petrusburg stations.

The work consists of

1. Remove all bushes and trees in the fence (1 metre both sides).
2. Plant of steel poles and struts as per specifications.
3. Spanning of 3 barbed wire as per specification as indicated red.
4. Spanning of 3 steel wire as per specification as indicated in red.
5. Fastening of droppers and Y standards.
6. Spanning of Veldspan both sides (section a)
- 6b. Spanning of standard 8 wire fence (section b)
7. Remove all excess material to Beaconsfield Depot
8. Remove all old material to Bloemfontein depot.

The work will be done by hand, and tenderers to provide all the necessary equipment needed to complete the works on Transnet property in the geographical area controlled by the Depot Engineer, Beaconsfield, Kimberley as per the Schedule of Quantities and Prices.

A.2 TO BE SUPPLIED BY TRANSNET

All fencing materials, including wire, straining poles, droppers and gates will be supplied at the Beaconsfield Infra Depot in Austen Street, Kimberley.

Site Access certificate and keys for access to mechanization roads.

A.3 TO BE SUPPLIED BY THE CONTRACTOR

The Contractor is responsible to supply his/her own labour, equipment, food, water and accommodation needed to complete the work covered by the contract.

The Contractor shall be responsible for the transport of all new fencing material to the work site from the Infra Depot in Austen Street, Beaconsfield, Kimberley

Further he/she will be responsible for the return of any old fencing material released during construction and excess material to the Infra Depot in Austen Street, Beaconsfield, Kimberley.

The Contractor shall provide safe and secure storage facilities and be responsible for all equipment and material brought onto the site.

The Contractor shall provide at his/her own cost any security measures he/she may deem necessary for safe and effective execution of the work within the work area.

Under no circumstances will Transnet provide accommodation facilities or sites for workers in the section.

Transnet Limited **Schedule of Plant** must include a suitable vehicle, on the contract site, for the transport of workers and material to or from the work site and to transport personnel in case of emergency to nearest hospital on a E.4 D document.

No tender will be considered unless the E.4 D document is completed.

Contractor to provide all tools and equipment to perform duties as described.

A.4 SITE MEETINGS

These meetings will be held under the chairmanship of the Technical Officer or his/her deputy. It is compulsory for contractors to attend on time.

A.5 SITE BOOKS

The Contractor shall provide two 100 leaf Triplicate Books (Croxley JD222 or similar) to use as a **Site Instruction Book** and a **Site Diary** at the site as directed by the Technical Officer for the duration of the contract.

The **Site Instruction Book** shall only be used by the Technical Officer or his/her deputy and will be used for the issuing of instructions to the Contractor.

The Contractor shall complete the **Site Diary** and a detailed description of the work done shall be recorded on a daily basis. The attendance register of contract workers is also to be written in the **Site Diary** as also his/her daily Safety Talk. Neither of the books shall be removed from the site without the permission of the Technical Officer or his/her deputy.

A.6 TEMPORARY CAMPS

No facilities are available at the mentioned work areas. The Contractor must arrange for all facilities needed, and these costs must be included in the tendered price. All camp facilities to be adhere to the Standard specification and Contractor will not start his/her contract until the Technical Officer is satisfied with the camp facilities.

A.7 VELD FIRES

Under no circumstances may the Contractor or his/her employees make fires within the Transnet reserve. The contractor will be liable for any damages caused by fires made by staff on site.

Under no circumstance may the Contractor or his employer collect wood within the Transnet reserve or on the adjacent farms.

PART B: PROJECT SPECIFICATIONS

B.1 SCOPE OF WORK

This contract covers the erection of fences and any associated work, to be performed by the Contractor for the successful completion of this contract, in accordance with the true meaning and intent of the contract document.

This contract calls for the supply of all equipment, transport and labour to complete the following tasks:

1. Provision of transport of new material from Infra Depot to work site.
2. Vehicle present at all times at working site
3. Cleaning 1 metre both sides of fence.
4. Erecting of new fence between kilometres stipulated above.
5. Erecting of steel poles concreted and stand for 7 days.
6. Erecting of all steel work to be done.
7. Provision of transport of excess and old material back to Infra Depot
8. Site to be left in condition as found at the start.

All the above work will be performed by the Contractor on Transnet property under the control of the Depot Engineer, Infrastructure Maintenance, Beaconsfield, Kimberley.

B.2 STANDARDS OF WORKMANSHIP

All work is to be done according to the relevant specifications.

KY-100-I-67 B

KY-100-I-67 F

Line book Plan (Blue = situation where work is to be completed new fence)

All the work must be carried out in accordance with the specifications of the contract.

Where material has been supplied by Transnet and the material has been spoilt during execution of the work the contractor will be responsible to make good.

All work will be approved by the Technical Officer before payment is affected.

B.3 DURATION OF WORK

The Contractor shall not exceed the maximum duration of work stipulated in the contract. He/she shall make available sufficient resources to complete the work as specified.

B.4 PROGRAMME OF WORK AND METHOD STATEMENT

The Contractor shall undertake the planning and programming of the work covered in the contract as stipulated in the Schedule of Quantities and Prices. **Proposed work programme and method statement to be submitted with the tender.**

B.5 PERFORMANCE MONITORING AND EVALUATION

The Contractor shall at all times be responsible for **supervision** of the work and for follow-up inspections to monitor the work performed.

The Technical Officer or his/her deputy may at any time during the operation carry out inspections of the Contractor's performance, methods and procedures.

The Contractor shall immediately take appropriate remedial action in areas where the specified standard of work is not achieved.

B.6 INSPECTION OF THE WORK

Inspection of the work will be done within one week after the Contractor has notified the Technical Officer in writing that the work has been completed.

If the work is found to be satisfactory, the Contractor must hand in his/her tax invoice for payment.

For the duration of this Contract, the Contractor is required to inspect the working process as well as remedial work.

B.7 REMEDIAL WORK

The Contractor shall carry out remedial work to all work where the standard of workmanship has not been achieved at **no cost** to Transnet.

The T/O may, at any time after the inspection order the Contractor to carry out remedial action, which is to be done within 7 working days after being ordered to do so.

Failure to commence with remedial work the Technical Officer may arrange for such action to be carried out by other Contractors at the cost of the responsible Contractor.

B.8 POLLUTION PREVENTION AND ENVIRONMENTAL AWARENESS

According to the Environmental Management System of Transnet, pollution must be prevented as far as possible and where pollution occurs due to the negligence of the Contractor, he/she will be responsible for corrective actions.

B.9 MEASUREMENT AND PAYMENT

Penalties of R100 per day will be levied for late completion of work.

Payment can be expected within 60 days after the invoice date.

PART C: HEALTH AND SAFETY

C.1 HEALTH AND SAFETY PLAN

Prior to the start of the contract the contractor is required to do a risk assessment of each task and to provide a safety plan to address these risks.

This safety plan is to be provided and implemented by the contractor before the work commences and a copy to be kept on site

The Contractor must adhere to this Safety Plan at all times.

The Contractor's **Health and Safety Programme** must make provision for the following risks.

- a. Working adjacent to passing trains.
- b. Transporting of material to and from work site.
- c. Transporting of people to and from site.
- d. Loading and off-loading of both new and old material.
- e. Working close to Overhead Traction equipment. Electrical shock.
- f. Uneven surfaces.
- g. Blue asbestos. (to be reported to Technical Officer immediately)
- h. Working with saws, wiring tools and digging tools.
- i. Working with barbed wire, high tensile steel wire and other steel material
- j. Veld fires.
- k. Transport of injured workers from work site to nearest hospital.

The contractor is to provide personal protection equipment (PPE) in relation to the risk and type of work to be executed.

All workers on this contract shall be required to wear reflective vests and safety boots at all times. (To be supplied by the Contractor).

Before the contractor may start any work, he/she and his/her entire team will be required to attend a compulsory Safety Induction given by a designated Transnet Safety representative.

The contractor or his/her supervisor will be responsible to hold a Safety Talk every morning before work commences (which is recorded in the Site Diary).

The contractor is to have available a suitable First Aid Kit and someone trained in first aid on site at all times.

The contractor is to have available a suitable Fire Fighting Equipment and someone trained in firefighting on site at all times.

No open fires are allowed on Transnet property. Any fires that may occur should be distinguished immediately at own costs. Any claims due to fire caused by the Contractor will be for his/her own account.

No work is to be done within a 3m distance of the railway line without the presence of a flagman.

All workers shall work as a team in one area in the Transnet reserve.

The contractor shall provide a cell phone, in good working order and with sufficient airtime, to his team leader to be available on site at all times.

The Contractor shall appoint at the work site sufficient personnel whose sole task shall be to be on the lookout for approaching rail traffic. These employees shall operate an audible warning device to timeously warn all people on the work site of approaching rail traffic.

In addition to risk assessment and safety plan, environmental management plan, quality control plan and Safe Operating Procedures that are specific to this job must be submitted prior to work commencement.

Schedule not to be changed after Contract has been posted in relevant Contract Box.

"PREVIEW ONLY COPY"

WEIGHT

Vispan- Petrusburg

Quotation for Fence Material

Type	Description	Unit	Amount	weight	total
Corner Posts	1800x100x 3mm post cap & base plate	each	2	8.7	17.40
Corner Posts	1800x 75x 3mm post cap & base plate	each	92	5.3	486.76
Stock Stays	1800x 50 x1.6 mm with base plate	each	32	3	95.84
Y Section Standards	1,85m high	each	271	3.5	948.70
T Section Droppers	1,40 m high	each	1815	0.5	907.25
Barbed Wire	IOWA 2,50 x 540 m	per roll	84	50	4200.00
High Strain Steel Wire	lightly galvanised 1500m oval 2x2.6mm	per roll	26	50	1300.00
Binding Wire	2 x 2015 m 50 kg	per roll	2	50	100.00
Gates	1,8m x 4,2m	each	2	3	6.00
BOLTS	M10x110mm length	each	32	0.1	3.19
nuts	m10	each	32		0.00
washers	m10	each	32		0.00
Cement	per 50 kg bag	each	41	50	2050.00
veldspan	10m rolls	sheets	126	50	6288.00
				TOTAL	16403.15

KG

W.E. Mc Callum

"PREVIEW ONLY"

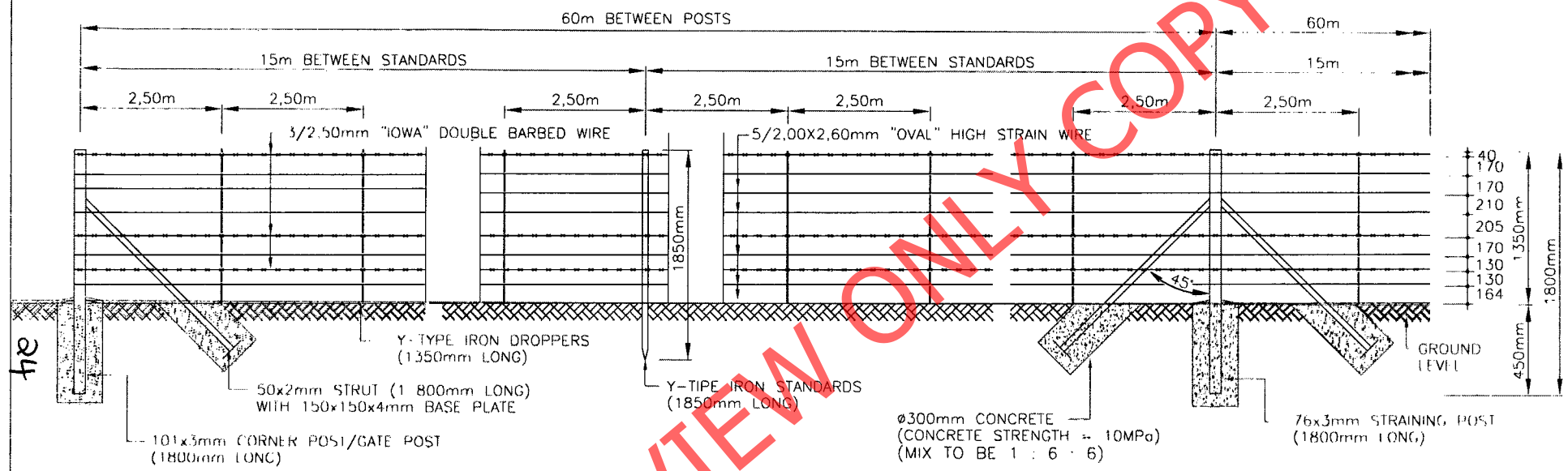

TYPICAL VIEW OF 8 WIRE FENCE - SMALL STOCK

"PREVIEW ONLY COPY"

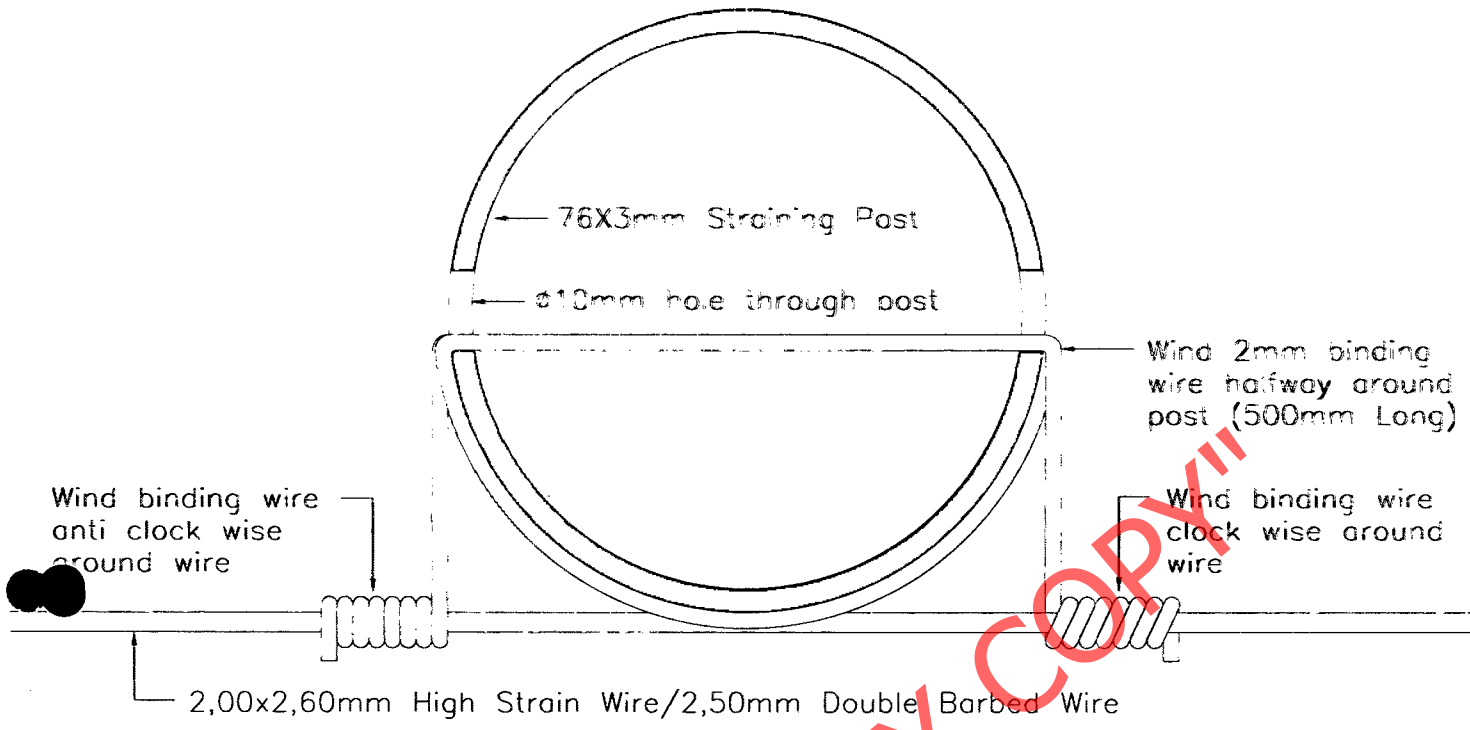

STRAINING POST @ 120m CENTERS

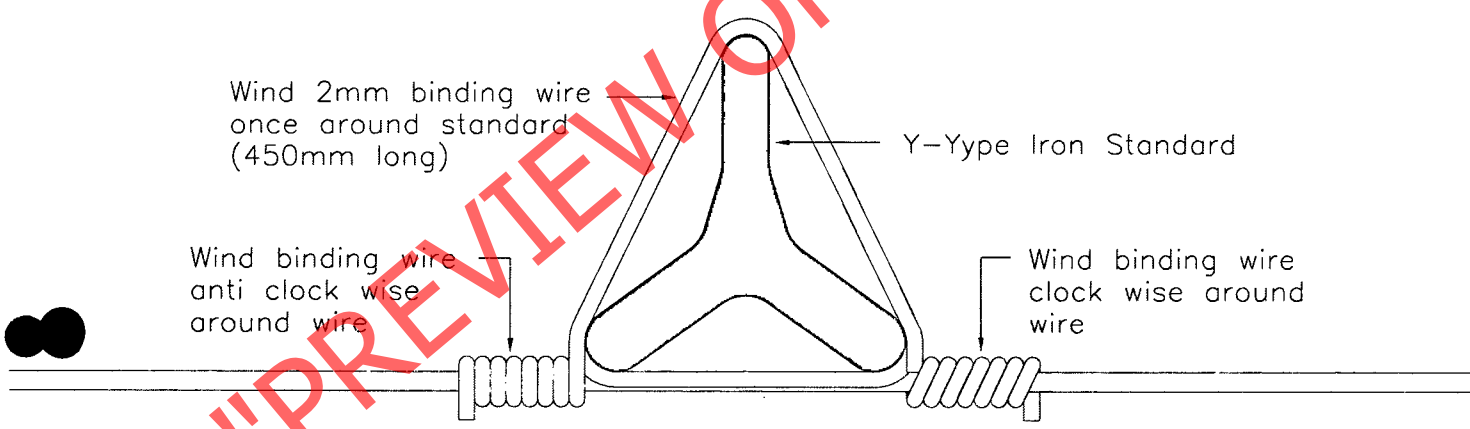

Y-TYPE STANDARD @ 15m CENTERS

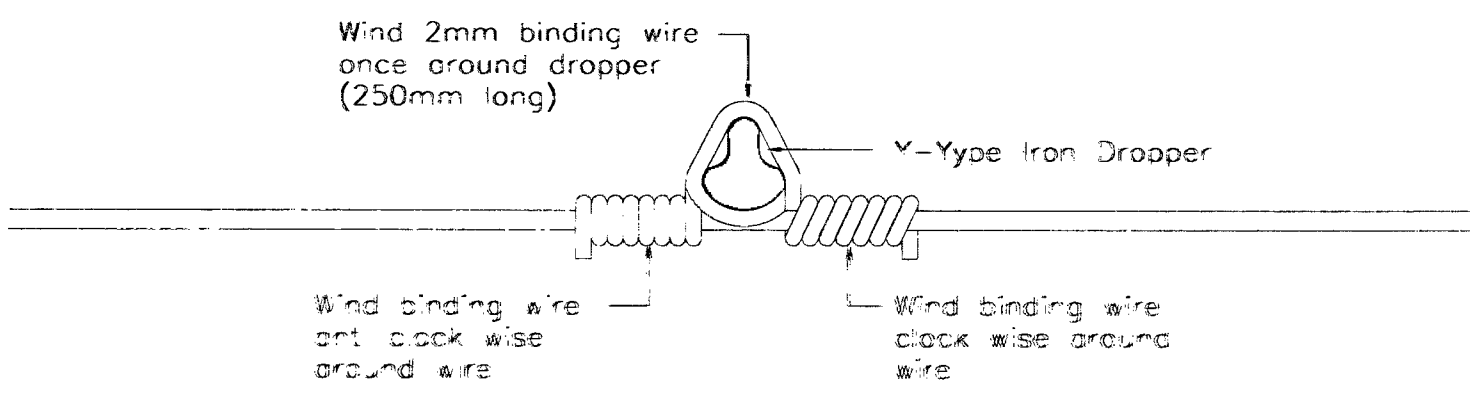

Y-TYPE DROPPER @ 2,5m CENTERS

a=erect an addition barbed wire (2 lengths)
b=erecting of veldspan fence

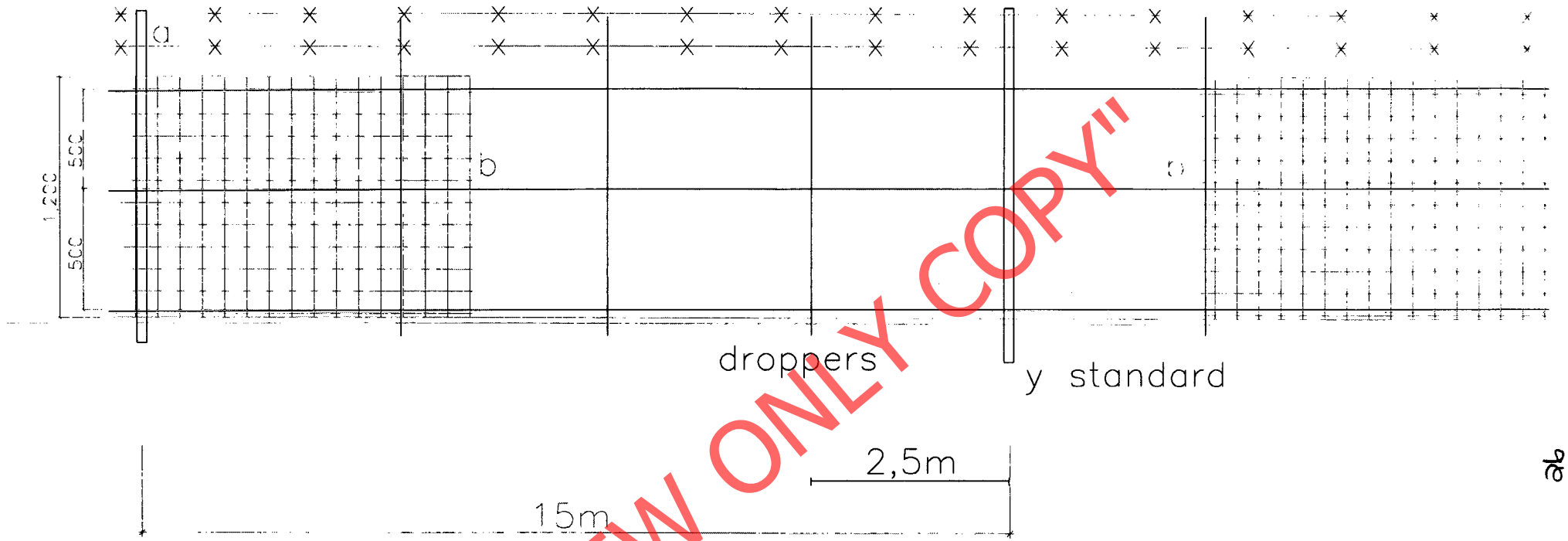

TYPICAL VIEW OF A VELDSPAN FENCE

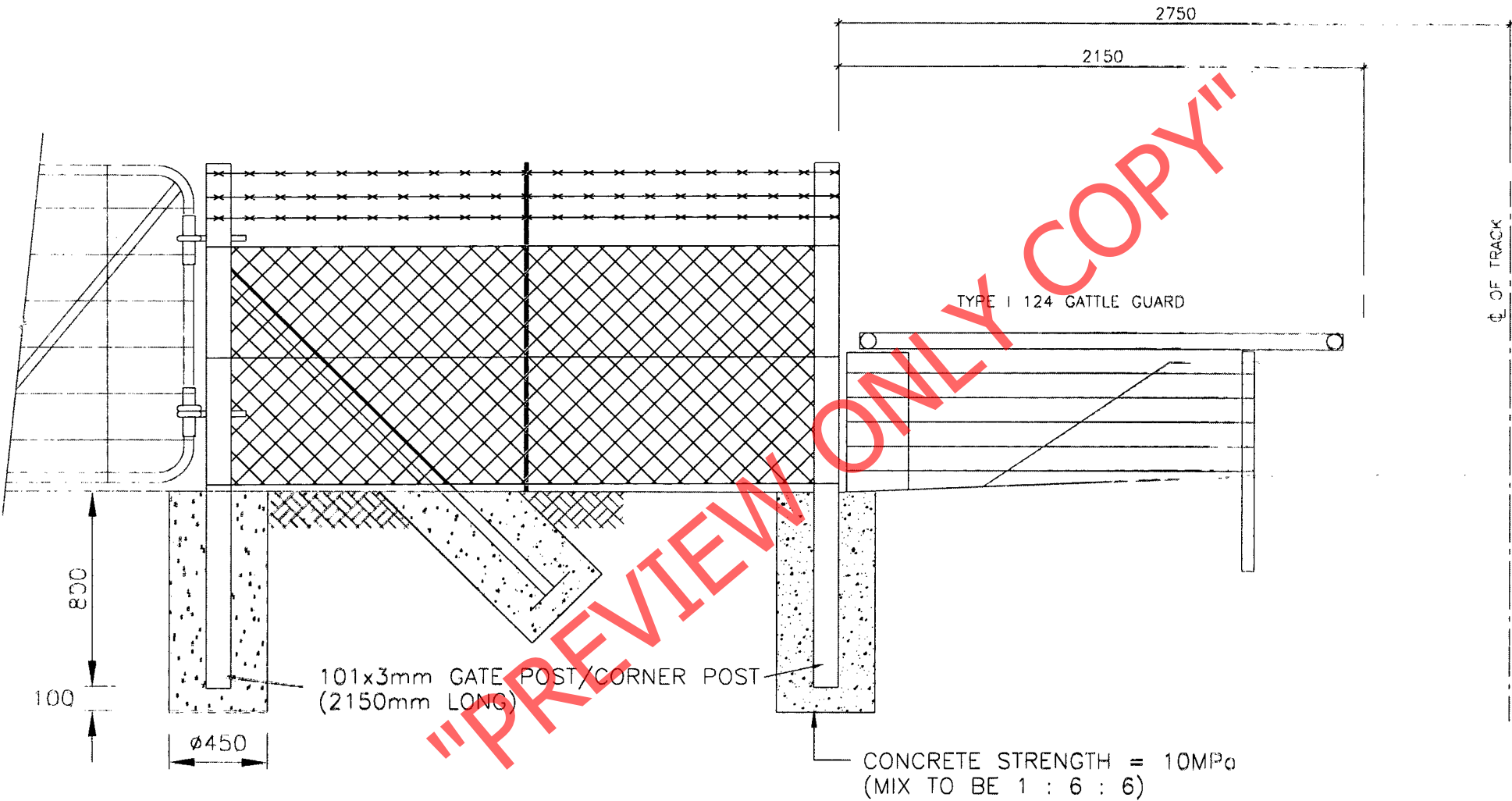

TYPICAL VIEW OF GATE POSTS AT CATTLE GUARDS

:		97.0515	GP	LEVEL	:
:		97.0510			:
:		97.0237	SQ/R		:
:	TROUGH TOP CULVERT	4,40m		1/2700x1200	:
:		97.0210	SQ/R		:
:		97.0175	SQ/R		:
:		97.0000	km		:
:	DWL+KOP				:
:	FLUIT 3,60	J			:
:	HP	96.9570			:
:	HP	96.9470			:
:		96.9425			:
:	O.T.P. ===	96.9340			:
:	FLUIT 3,10	J			:
:		96.7053			:
:	HP	96.5862		HP	:
:		96.5844			:
:	6 BLOKKE	96.5824			:
:	PRIVAAT	96.5800	GRUIS OORGANG		:
:	6 BLOKKE	96.5783			:
:		96.5771	15,70	HP	:
:	HP	96.5758			:
:	TELKOM-ROETE	96.5345	2 DRADE		:
:		96.5000	km		:
:		96.4940			:
:		96.4550	3,00	FLUIT	:
:	L=55 K=20 EODL<	96.3450			:
:	S=1563 M=5 ESDL<	96.2900			:
:		96.2060	3,10	FLUIT	:
:	FC	96.1355		FC	:
:		96.0825	SQ/R		:
:	TROUGH TOP CULVERT	4,30m		1/2750x600	:
:		96.0800	SQ/R		:
:		96.0774	SQ/R		:
:		96.0000	km	GEEL DWL (ZERO)	:
:	FC	15,90		15,20	FC
:	S=1563 M=5	95.9330			:
:	FJ	95.7750	BSDL<		:
:		95.7126			:
:	L=65 K=20	95.7100	BODL<		:
:	O.T.P. ===	95.6680			:
:		95.5000	km		:
:		95.4003		FJ	:
:		95.0695			:
:		95.0690	GP	\617	:
:		95.0685		\425	:
:	FJ	95.0560			:
:		95.0000	km		:
:		94.9220	====	O.T.P.	:
:		94.7890	>EODR	K=20 L=60	:
:		94.7290	>ESDR	M=7 S=1750	:
:	FC	15,54		15,90	FC
:		94.5620			:
:		94.5000	km		:
:		94.3780	>BSDR	M=7 S=1750	:
:		94.3130	>BODR	K=20 L=65	:
:		94.3075		\425	:
:		94.3070	GP	\510	:
:		94.3065			:
:	FJ	94.0780			:
:	DWL+KOP	94.0000	km		:
:	O.T.P. ===	93.9390			:
:	FJ	93.8342			:
:		93.7960		FJ	:
:	ESKOM-ROETE	93.7900	/\---	3 DRADE	:
:		93.7840		FJ	:
:	FJ	93.5650			:
:		93.5000	km		:
:		93.3315		\510	:
:		93.3310	GP	\1000	:
:		93.3305			:
:	FJ	93.2390			:
:	ESKOM-ROETE	93.1930	/\---	3/2+2 DRADE	:
:	DWL+KOP	93.0000	km		:
:	O.T.P. ===	92.9400			:
:	FJ	92.7120			:
:		92.6880		FJ	:

"PREVIEW ONLY" COPY

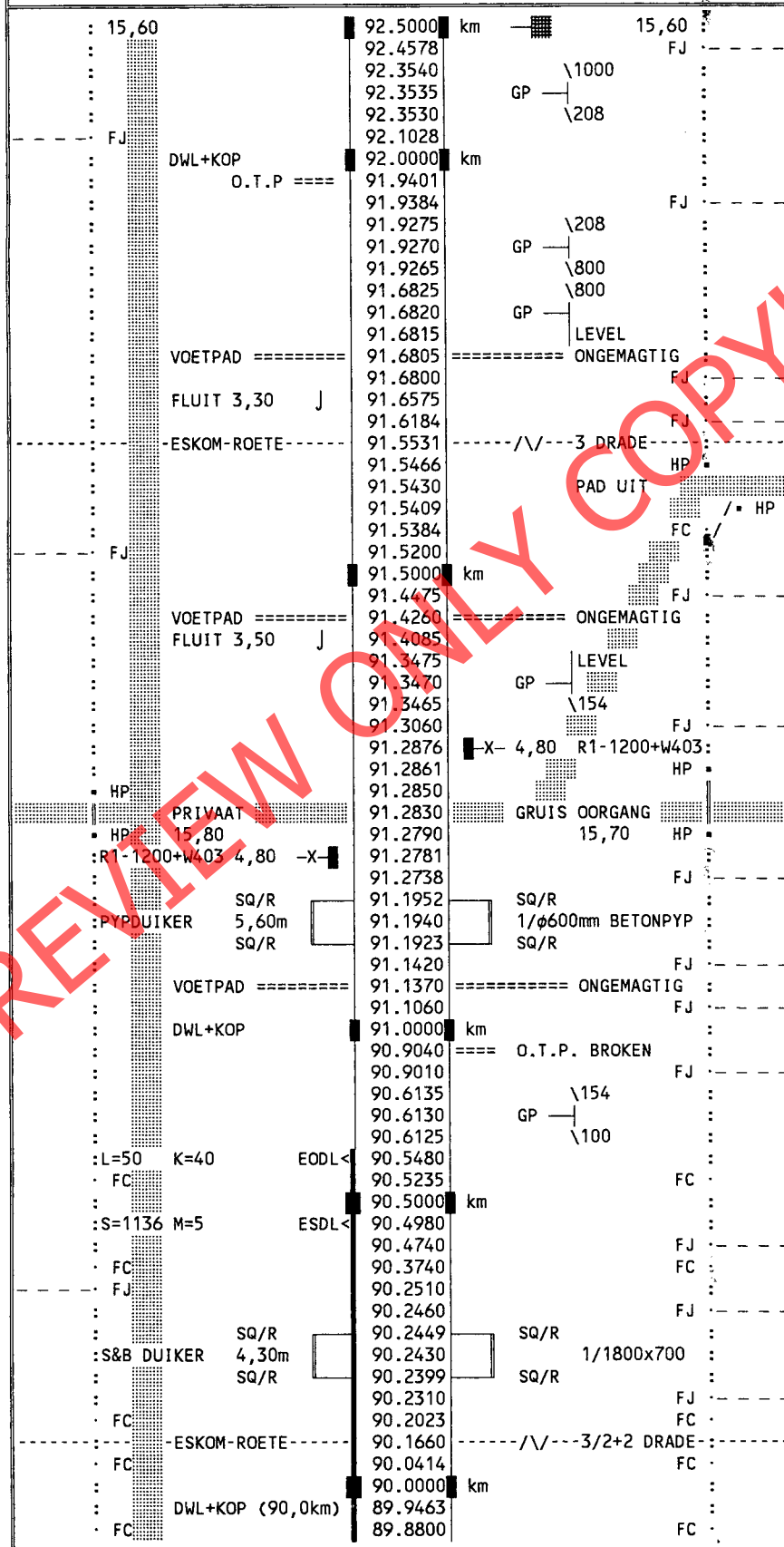

FC	15,60	89.7176	15,60	FC
:		89.7030		FJ
:S=1136	M=5	BSDL<	89.5830	:
:L=50	K=40	BODL<	89.5330	:
:		89.5000	km	:
:		89.4270	==== O.T.P.	:
:	FLUIT 3,30	J	89.2450	:
:	DWL+KOP		89.0000	km
:	FLUIT 3,10	J	88.9955	:
FJ			88.9330	:
:	O.T.P. ===		88.9000	:
HP			88.8651	HP
	4 BLOKKE		88.8644	
	PRIVAAT		88.8630	GRUIS OORGANG
	4 BLOKKE		88.8615	
HP	15,70		88.8599	HP
:			88.7295	f 3,30 FLUIT
-	ESKOM-ROETE	-	88.5470	/\---3/2+2 DRADE
:			88.5000	km
FJ			88.4995	:
:	VOETPAD	=====	88.4800	f 3,50 FLUIT
:	SQ/R		88.1256	ONGEMAGTIG
-	KRAGKABEL	-	88.1126	SQ/R
:	PYPDUIKER 4,80m		88.1115	DEUR PYP
-	φ200mm WATERPYP	-	88.1110	2/φ450mm BETONPYPE
:	SQ/R		88.1100	DEUR PYP
-	ESKOM-ROETE	-	88.1094	SQ/R
:			88.0620	/\---3+2 DRADE
:	VOETPAD	=====	88.0550	FJ
:			88.0420	ONGEMAGTIG
:			88.0355	FJ
:	15,70 DWL+KOP		88.0000	km
BROKEN	O.T.P. ===		87.9520	15,80
:	VOETPAD	=====	87.8450	ONGEMAGTIG
:			87.5630	\724
:			87.5625	GP
:			87.5620	\100
:			87.5000	km
:	GABION W/W		87.3835	GABION W/W
S&B DUIKER	6,10m		87.3810	1/1800x1000
GABION W/W			87.3788	GABION W/W
FJ			87.2635	:
:			87.2525	FJ
:			87.0080	==== O.T.P.
:	15,60 DWL+KOP		87.0000	km
:			86.5000	km
:			86.4593	FJ
FC	15,60		86.3730	>EODR K=50 L=85
:			86.3320	15,90 FC
:			86.2880	>ESDR M=17 S=735
S.W.B.		4,40	86.2042	:
FC	15,90		86.1625	15,60 FC
TROUGH TOP CULVERT	4,30m		86.1484	SQ/R
:	SQ/R		86.1450	1/2750x1200
:	SQ/R		86.1424	SQ/R
FC	15,70		86.0210	:
:	DWL+KOP		86.0000	km
:			85.9498	17,70 FC
FC	13,30		85.9484	:
:			85.9340	>BSDR M=17 S=735
:			85.8695	\138
:			85.8690	GP
:			85.8685	\100
:			85.8490	>BODR K=50 L=85
:			85.7620	==== O.T.P. BROKEN
:			85.5000	km
:	FLUIT 3,65	J	85.3050	:
FJ			85.2357	:
:	FLUIT 3,50	J	85.0561	:
:	O.T.P. ===		85.0030	:

TRAJEK: HAMILTON ----- BEACONSFIELD DATUM: 2005.10.10 BLADSY: 33

