



RFQ / TENDER

Tender No: BLE52484

Vendor No: 11001386

BOARD LIST
 BOARD LIST
 TRANSNET FREIGHT RAIL
 PROCUREMENT DEPARTMENT
 2000

Purchaser : Cobus Carstens
 Telephone : 021 940 3833
 Fax Number : 021 940 3883

Please quote reference:
 A07/6000595314

Deliver to:
 TFR Western Cape
 Supply Chain Services
 Salt River
 8000 See below

Closing Date : 09.10.2013
 Validity Date : 23.11.2013
 RFQ No : 6000595314

"PREVIEW COPY ONLY"

Prices in South African currency
 including the cost of packing and packing
 materials for delivery as follows:

A:	B:	C:
DIRECT	DIRECT	EX OVERSEAS
by rail to	by other	WORKS
destination	means to	
point	destination	
(Railage a/c	point	
.....)		

Item	Qty	Material	Description
------	-----	----------	-------------

00010	1	UPGRADE FENCE PAROW NORTH STATION	
-------	---	-----------------------------------	--

R.....	R.....	R.....
Each	Each	Each

Delivery Date: 23.11.2013

FULL DETAILS OF DESCRIPTION

RFS BLE52484 : UPGRADE TRANSNET BOUNDARY FENCE AT PAROW NORTH STATION:

See the attached specifications.

Please complete the Schedule of Rates & Prices / Price list, Annexure C. Total price to be forwarded to the RFQ document (front page).

DATE: SIGNATURE OF TENDERER(S):
 CONTACT PERSON: TEL No:

RFQ / TENDER

Tender No: BLE52484
Date : 23.09.2013

Page
2

BOARD LIST
TRANSNET FREIGHT RAIL
PROCUREMENT DEPARTMENT

Prices in South African currency
including the cost of packing and packing
materials for delivery as follows:

A: DIRECT by rail to destination point (Railage a/c)
B: DIRECT by other means to destination point
C: OVERSEAS WORKS

Item	Qty	Material	Description
------	-----	----------	-------------

Closing date : 9 October 2013

Transnet indemnifies itself from any claims which may arise as a result of a Bidder not being able to transmit his / her quote to Transnet for any reason whatsoever before the closing time.

I/We _____ hereby confirm we have read the specifications and clearly understand the requirements and offer to supply the goods/services at the prices quoted in the Price Schedule below, in accordance with the conditions related thereto.

INSTRUCTIONS FOR COMPLETING THE RFQ

The following returnable documents must accompany all Quotations:

- Respondent's latest audited financial statements;
- Respondent's valid Tax Clearance Certificate.
- Respondent's BBBEE certificate
- Completed Supplier Declaration Form
- Completed Annexure C - Price list / Schedule of Rates.

DISCLAIMERS

Respondents are hereby advised that Transnet is not committed to any course of action as a result of its issuance of this RFQ and/or its receipt of a Quotation in response to it. In particular, please note that Transnet reserves the right to:

- " modify the RFQ's Services and request Respondents to re-bid on any changes
- " reject any Quotation which does not conform to instructions and specifications which are detailed herein
- " disqualify Quotations submitted after the stated submission deadline
- " not necessarily accept the lowest priced Quotation
- " reject all Quotations, if it so decides

DATE:

SIGNATURE OF TENDERER(S):

RFQ / TENDER

Tender No: BLE52484
Date : 23.09.2013

Page
3

BOARD LIST
TRANSNET FREIGHT RAIL
PROCUREMENT DEPARTMENT

Prices in South African currency
including the cost of packing and packing
materials for delivery as follows:

A: DIRECT by rail to destination point (Railage a/c)
B: DIRECT by other means to destination point
C: OVERSEAS WORKS

Item	Qty	Material	Description
------	-----	----------	-------------

- " award a contract in connection with this Quotation at any time after the RFQ's closing date
- " award only a portion of the proposed Services which are reflected in the scope of this RFQ
- " split the award of the contract between more than one Supplier
- " make no award of a contract

Kindly note that Transnet will not reimburse any Respondent for any preparatory costs or other work performed in connection with this Quotation, whether or not the Respondent is awarded a contract.

CLOSING DATE

9 October 2013 at the Transnet Park Building, Room 306, Sobukwe road, Bellville.

The returnable documents may be e-mailed to Carol Swann tel: 021 940-3846 e-mail carol.swan@transnet.net

"PREVIEW COPY ONLY"

DATE:

SIGNATURE OF TENDERER(S):

RFQ NUMBER 6000595314

Ref no : BLE52484

UPGRADE TRANSNET BOUNDARY FENCE WITH BETA FENCE AT PAROW NORTH STATION FROM GIEL BASSON BRIDGE

1. RFQ document
2. BBBEE document
3. Annexure A – Project Specifications
4. Annexure B – Special Conditions
5. Annexure C - Price list
6. Annexure D - Drawings
7. SBR document
8. E4E - safety arrangements (act 85 of 1993)
9. E7/1 - specification for general work and works on, over, or adjacent to railway lines and near high voltage equipment



1 Broad-Based Black Economic Empowerment [B-BBEE]

Transnet fully endorses and supports the Government's Broad-Based Black Economic Empowerment Programme and it would therefore prefer to do business with local business enterprises who share these same values. Transnet will accordingly allow a "preference" to companies who provide a B-BBEE Verification Certificate. All procurement transactions will be evaluated accordingly.

1.1 B-BBEE Scorecard and Rating

As prescribed in terms of the Preferential Procurement Policy Framework Act (PPPFA), Act 5 of 2000 and its Regulations, Respondents are to note the following:

- Proposals will be evaluated on price which will be allocated 80 points and preference which will be allocated 20 points, dependent on the value of the Services
- The 80/20 preference point system applies where the acquisition of the Services will be less than R1 000 000.00.
- If the 80/20 preference point system is stipulated and all Bids received exceed R1 000 000.00, the RFP will be cancelled

In compliance with the Government Gazette No. 34612, notice No. 754 dated 23 September 2011, as from 1 October 2011 valid B-BBEE Verification Certificates must be issued by:

- a) Verification Agencies accredited by the South African National Accreditation System [SANAS]; or
- b) Registered Auditors approved by the Independent Regulatory Board of Auditors [IRBA], in accordance with the approval granted by the Department of Trade and Industry.

Enterprises will be rated by such agencies based on the following:

- c) **Large Enterprises** [i.e. annual turnover greater than R35 million]:
 - Rating level based on all seven elements of the B-BBEE scorecard
- d) **Qualifying Small Enterprises – QSE** [i.e. annual turnover between R5 million and R35 million]:
 - Rating based on any four of the elements of the B-BBEE scorecard
- e) **Exempted Micro Enterprises – EME** [i.e. annual turnover less than R5 million]:

In accordance with B-BBEE Codes of Good Practice [Statement 000, Section 4], any enterprise with an annual total revenue of R 5 million or less qualifies as an EME.

- Automatic rating of B-BBEE Level 4 irrespective of race or ownership
- Black ownership greater than 50% or Black Women ownership greater than 50% automatically qualify as B-BBEE Level 3

Sufficient evidence to qualify as an EME would be a certificate (which may be in the form of a letter) from an auditor or accounting officer or a certificate from a Verification Agency accredited by SANAS. The certificate must confirm the company's turnover, black ownership / black female ownership and B-BBEE status level.



Respondents are required to furnish proof of the above to Transnet. [i.e. a detailed scorecard as stipulated above in respect of Large Enterprises and QSEs, or a certificate in respect of EMEs].

Transnet will accordingly allocate a maximum of **20 [twenty] points** in accordance with the **80/20** preference point system prescribed in the Preferential Procurement Policy Framework Act (PPPFA), Act 5 of 2000 and its Regulations to the Respondent's final score based on an entity's B-BBEE scorecard rating.

N.B. Failure to submit a B-BBEE certificate, which is valid as at the Closing Date of this RFP, will result in a score of zero being allocated for B-BBEE.

2 Evaluation Criteria

Transnet will utilise the following criteria in choosing a Supplier/Service Provider:-

- Weighted evaluation based on 80/20 preference point system:

Transnet will utilise the following formula in its evaluation of Price:

$$PS = 80 \left(1 - \frac{Pt - Pmin}{Pmin} \right)$$

Where:

Ps = Score for the Bid under consideration
Pt = Price of Bid under consideration
Pmin = Price of lowest acceptable Bid

- B-BBEE status of company

Preference points will be awarded to a bidder for attaining the B-BBEE status level of contribution in accordance with the table below:

B-BBEE Status Level of Contributor	Number of points (80/20 system)
1	20
2	18
3	16
4	12
5	8
6	6
7	4
8	2
Non-compliant contributor	0

TRANSNET



freight rail

TRANSNET LIMITED

(REGISTRATION NO.1990/000900/30)

TRADING AS TRANSNET FREIGHT RAIL

ANNEXURE A

BLE 52484 : UPGRADE TRANSNET BOUNDARY FENCE WITH BETA FENCE AT PAROW NORTH FROM GIEL BASSON BRIDGE TO KM 15P4 ON THE LEFT HAND SIDE (Opposite Parow Gholf Coarse).

SPECIAL CONDITIONS

PART A: GENERAL

A.1 SCOPE OF WORK :

This specification covers the erection of BETA Fencing along the Transnet boundary between Monte Vista and De Grendel Stations on the Cape Town to Bellville Railway Line in the geographical area controlled by the Depot Engineer, Bellville, hereinafter referred to as the "Works", and any other work arising out of or incidental to the above, or required of the Contractor for the proper completion of the Works in accordance with the true meaning and intent of the contract.

A2 SUFFICIENCY OF TENDER

A2.1 The contract will only be awarded to a tenderer who has experience in the field of erecting BETA fencing.

A2.2 The Certificate of Attendance of the Briefing Session/Site Meeting signed by the Technical Officer or his/her deputy (compulsory) must be submitted with the tender. The attendance of this briefing session/site meeting is compulsory. The submission thereof will be deemed to indicate the Contractor's acquaintance with the occurrence and extent of species of vegetation to be controlled and all aspects that will and/or may affect such control and costs thereof.

A.3 DURATION OF CONTRACT :

The contract will commence within 7 working days of the date of acknowledgement of receipt of the notification of acceptance of tender with Transnet Freight Rail.

Transnet Freight Rail requires that the works be completed within eleven (11) weeks from the date of commencement of the work.

A.4 MAINTENANCE PERIOD:

N I L

A.5 RETENTION MONEY:

N I L

A.6 PENALTIES FOR LATE COMPLETION :

A penalty for late completion as per Clause A.3 of **R1000.00** per calendar day shall apply for each working day or part thereof. In addition, no extra payment will be made for delays suffered by the Contractor as a result of inclement weather, flooding or delays caused by Transnet Freight Rail.

A.7 MATERIAL

A.7.1 TO BE SUPPLIED BY TRANSNET FREIGHT RAIL:

Transnet Freight Rail will provide all the material for the BETA Fence (at Bellville Yard) except for the sand, stone, cement and water.

A.7.2 TO BE SUPPLIED BY THE CONTRACTOR:

All cement, sand, stone, and all necessary welding (if any), etc. used to erect the fence, shall be supplied by the Contractor.

A.7.3 SAFE KEEPING OF MATERIAL :

1. The Contractor shall be responsible for the safe keeping, proper staging and handling of all fencing materials.
2. All packaging or waste material associated with the material will be taken off site and properly disposed of by the Contractor.

A.8 TO BE PROVIDED BY THE CONTRACTOR :

1. The Contractor shall supply all labour, vehicles, machinery, small plant and any mechanised equipment for the proper execution of the works and in addition to this the Contractor shall provide all accommodation and toilet facilities for his/her employees. No accommodation shall be erected on Transnet Freight Rail property.
2. All tools and labour required to perform the work as stipulated in the schedule of quantities shall be provided by the Contractor and included in his tendered rates. These include:
 - 2.1. All fuel for small plant tools, lubricants, etc.
 - 2.2. Staff accommodations complete with ablutions and kitchen facilities.
 - 2.3. Fire prevention and fire fighting measures.
3. The maintenance, leasing, hiring and insurance of this equipment will solely rest with the Contractor.
4. The Contractor shall be responsible for his own arrangements with regards to the transport and safe staging of this equipment.
5. The Contractor shall appoint at each work site sufficient personnel whose sole task shall be to be on the look out for approaching rail traffic. These employees shall operate an audible warning device to timeously warn all people on the work site of approaching rail traffic.
 - 5.1. An effective safety procedure to be followed by all personnel on any work site in the case of approaching rail traffic shall be compiled by the Contractor and implemented before any work commences. The procedure shall be updated whenever the need arises and any changes shall be communicated to all employees on a work site before work proceeds.
 - 5.2. The personnel of the Contractor shall **at all times** during work operations wear **reflective safety jackets**. These reflective jackets must either be yellow or light blue. Any other colour must first be cleared with the Technical Officer or his Deputy.
 - 5.3. Contractor's **staff** working on the site **may not wear any form of visible red or green outer garments**.
 - 5.4. The Contractor shall make available employees to be trained, certificated and used as lookouts when required. The training shall be done at no cost to the Contractor.
6. The making of fires, for whatever purpose, on Transnet property is strictly prohibited.

A.9 ADVANCE PAYMENT FOR MATERIAL AND/OR PLANT AND/OR EQUIPMENT SUPPLIED BY THE CONTRACTOR:

No advancement of any monies will be considered.

A.10 CONTRACT PRICE ADJUSTMENT FACTOR :

The contract shall not be subject to cost escalation or de-escalation or foreign exchange rate fluctuations. All increases in cost from whatsoever cause shall be at the Contractor's risk, and all decreases in cost shall be to his benefit.

A11 SCHEDULE OF QUANTITIES AND PRICES

A11.1 The quantities in the Schedule of Quantities and Prices, located at section 6 (Service Fees and Costs), are estimated and may be more or less than stated. The Contractor shall submit with his/her tender a complete and detailed priced Schedule (prepared in blank) for the Works.

A11.2 The Tenderer shall price each item. If the Contractor has omitted to price any items in the Schedule, the cost of the work included in such items will be held to be spread over and included in the prices given in the other items of work.

A11.3 The short descriptions of the items in the Schedule are for identification purposes only. The Special Conditions of Contract and Specifications shall be read in conjunction with the Schedule. In so far as these documents have any bearing, they shall be referred to for details of the description, quality, and test of plant and material used, and the workmanship, conditions, obligations, liabilities and instructions generally, which shall be complied with in carrying out the Contract. The cost of complying with all conditions, obligations and liabilities described in the contract documents including profit, shall be deemed to be included in the rates quoted by the Contractor in the Schedule of Quantities and Prices.

A.12 PROTECTION FROM STORMS AND FLOODS :

The sum allowed for in the Schedule of Quantities shall be deemed to be full compensation for any damage to the works due to storms, rains, floods, storm-water or subsurface water.

Under no circumstances shall the **Contractor** be entitled to any additional payment in this regard. The **Contractor** shall accept full responsibility and costs to handle water from any source on site.

A.13 VALUE ADDED TAX

Value-added tax in terms of the Value-added Tax Act No. 89 of 1991 should not be included in the tendered rates. Provision is made in the Schedule of Quantities and Prices for the lump addition of Value-added Tax.

A14 SITE MEETINGS

A14.1 The Contractor shall attend site meetings when required. These meetings will be held under the chairmanship of the Technical Officer or his/her deputy. When sub-contractors are required to attend, the Contractor shall ensure their attendance.

A14.2 An inaugural site meeting, under the chairmanship of the Technical Officer, will be held at the work site. The attendance of this meeting is compulsory by the Contractor and ALL his staff who will be working on the site. During this meeting, the Contractor and his staff will receive instruction from a Transnet Safety Officer Representative regarding:-

- i. the specific hazards, safety, health and environment rules for Transnet Freight Rail premises and
- ii. on-site instructions regarding Risk Assessment, action plans to mitigate risks, introduction to key personnel and substance abuse testing

- A14.3 If for any reason the Contractor changes his staff, the new staff, before they enter on to the worksite, MUST undergo an induction session conducted by a Transnet Safety Officer Representative.
- A14.4 Site meetings, will be held once a week as arranged with the Technical Officer and are to be attended by the Technical Officer and the Contractor.

A15 SITE BOOKS

- A15.1 The Contractor shall provide a **site instruction book and a daily diary (both in triplicate) as well as a Safety File at the site** as directed by the Technical Officer for the duration of the contract.
- A15.2 The site instruction book shall only be used by the Technical Officer or his/her deputy and will be used for the issuing of instructions to the Contractor.
- A15.3 The Contractor shall complete the daily diary and a detailed description of the work done shall be recorded on a daily basis. Neither of the books shall be removed from the site without the permission of the Technical Officer or his/her deputy.
- A15.4 Upon the completion of the contract, both books are to be handed in to the Technical Officer and both become the property of Transnet Freight Rail.

A16 INFORMATION TO BE PROVIDED WITH TENDER

- A16.1 A full description of the plant and equipment to be used by the Contractor for all aspects of the work required to ensure standard as specified.
- A16.2 Whether the tenderer intends to work on Saturdays, Sundays or statutory holidays or is prepared to work on such days if required to do so by Transnet freight Rail.
- A16.3 Proof of inspection of all sites on the enclosed Site Inspection Certificate.
- A16.4 An undertaking that all plant and equipment will be ready for operation and that the work can commence timeously, to comply with requirements of the contract.
- A16.5 The contractor must indicate whether he/she intends using sub-contractors. No sub-contractors will be allowed on site without the prior permission of the Technical Officer.

A.17 SAFETY REQUIREMENTS :

1. High voltage electrical equipment : (If applicable)

- 1.1. The attention of the **Contractor** is drawn to the possibility of "live" electrical overhead wires or buried cables in the area covered by the contract and the danger of coming into contact with such wires. All personnel under the control of the **Contractor** shall be made aware of the danger of "live" electrical wires and cables before commencement of the work
- 1.2. The **Contractor** shall comply with all requirements of the **E7/1 (July 1998)** Specification. In particular the **Contractor** shall not be allowed to drive or move mobile equipment on or over the ballast and track-work unless the Technical Officer grants suitable permission and proper methods are employed.
- 1.3. **Protection:** The Contractor shall provide all protection functions at the work area as required by the Technical Officer and according to the rules and regulations as stipulated in the **Infrastructure safety guidelines, page 51 to 72.**

The **Contractor** shall be liable for costs incurred by Transnet as a result of failure on the part of the **Contractor** or his personnel, to observe any safety and security regulations of Transnet regarding the entry of personnel into all sites. Transnet will determine such costs.

A.18 TECHNICAL REQUIREMENTS AND EXPERTISE :

1. The **Contractor** shall have a qualified **site agent**, fully conversant with fencing practices of Transnet, in his employment. The Contractor must furnish the name and qualifications of the site agent with his tender.
2. The **Contractor** shall have suitably qualified supervisors in charge of the contract work. The names and qualifications of the supervisors together with full details of their experience in this field of work must be furnished with the tender.
3. The **Contractor** shall have a min of 3 suitable qualified persons for the exclusive use as **protection staff** per work site under occupation conditions. The protection staff has to be trained and certified by a Transnet Track Inspector. Transnet reserves the right to test the protection staff at random to ensure that they are working safely and correctly according to the stipulated rules and regulations.

FAILURE TO COMPLY WITH SUB CLAUSES A.18.1 TO A.18.3 WILL AUTOMATICALLY DISQUALIFY THE TENDERER.

4. The **Contractor** shall note that all members of Transnet's personnel associated with the contract project are responsible for inspection only and will not render any assistance except at the instruction of the Technical Officer.

A.19 TIDINESS AND CLEARING OF SITE

The Contractor shall keep the site tidy at all times and remove all old material such as rubble, off-cuts, demolished material, surplus material and carry away and dump or store onto or at an approved site.

A permit must be obtained from the Municipalities to transport material on their roads, when required.

On completion of the **WORKS**, the Contractor shall clear the site of all leftover items of material, rubble etc to the satisfaction of the Technical Officer.

A.20 EXISTING SERVICES :

The **Contractor** shall take all reasonable precautions to protect existing services during construction and during relocation of such services.

Any pipe, cable, conduit or other services of any nature whatsoever indicated to the **Contractor** and subsequently damaged as a result of the **Contractor's** operations, shall be repaired and reinstated forthwith by the **Contractor** or by the Authority concerned, all at the expense of the **Contractor** and to the satisfaction of the Technical Officer.

Whenever unknown services are encountered which interfere with the execution of the Works and which require to be moved and relocated, the **Contractor** shall advise the Technical Officer, in writing within 24 hours of such encounter, and the Technical Officer will determine the extent of the work, if any, to be undertaken by the **Contractor** in removing, relocating and reinstating such services.

Any work required to be undertaken by the **Contractor** in the moving and relocation of unknown services for which no provision is made in the contract documents, or for which no applicable tender rates exists, will be dealt with according to Clause A13 hereto.

The sum allowed for in Schedule of Quantities (Section 6) shall be deemed to be full compensation for the location and protection of existing services.

A21 DAMAGE TO ADJOINING PROPERTY

The Contractor shall ensure that no damage occurs to adjoining property.

The Contractor shall negotiate with the property owner(s) for permission to work on their land for the purpose of carrying out the work (if necessary)

The Contractor shall ensure that his workmen do not abuse any permissions granted by adjoining property owners allowing them on to their property for the execution of the work.

Annexure A. 52484

"PREVIEW COPY ONLY"

TRANSNET LIMITED

(REGISTRATION NO.1990/000900/30)

TRADING AS TRANSNET FREIGHT RAIL

Annexure B

**BLE52484 : UPGRADE TRANSNET BOUNDARY FENCE WITH BETA FENCE AT PAROW NORTH
FROM GIEL BASSON BRIDGE TO KM 15P4 ON THE LEFT HAND SIDE
(Opposite Parow Gholf Coarse).**

PROJECT SPECIFICATION

B.1 GENERAL.

This specification covers the erection of BETA Fencing along the Transnet boundary between Monte Vista and De Grendel Stations on the Cape Town to Bellville Railway Line in the geographical area controlled by the Deputy Engineer, Bellville, hereinafter referred to as the "Works", and any other work arising out of or incidental to the above, or required of the Contractor for the proper completion of the Works in accordance with the true meaning and intent of the contract.

B1.2 This part covers the techniques, required standards of workmanship, inspections, measurement, payment, and acceptability of the works in respect of erecting the BETA fence required in terms of the contract.

B1.3 The ways and means by which the above-mentioned results are obtained are the responsibility of the Contractor. Transnet Freight Rail, however, shall have the right to monitor the materials and activities of the Contractor to ascertain that all procedures are in accordance with his/her tender and relevant legislation. Such right of monitoring shall be entirely without prejudice to Transnet Freight Rail and shall in no way relieve the Contractor of his/her responsibility for satisfactory erection of the fence.

B1.4 Failure to comply with the minimum standard proposed by the Contractor in his/her tender may form the basis for non-payment for work done, pending the standard as defined and/or termination or cancellation of the contract.

The performance due by the Contractor shall include any work arising from or incidental to the above or required of the Contractor for the proper completion of the contract in accordance with the true meaning and intent of the contract documents.

B.2 STANDARD SPECIFICATIONS

In so far as they can be applied and where they are not inconsistent with the terms of this specification, the following specifications shall be regarded as being embodied in this specification:

1. Concrete (Small works) – SABS 1200GA – 1982
2. Earthworks – Standardized specification for civil engineering construction Section D: Earthworks – SANS 1200D:1988
3. Guidelines for the provision of engineering services in Residential Townships - by Department of Community Development.

B3 WORK AREA.

On the Left Hand Side from the Giel Basson Bridge to an existing wall opposite MP 15/4 - a distance of ± 1133 metres. - Erect a 2.4m high BETA fence along the existing Transnet

boundary with a concrete plinth underneath of 200mm wide x 300mm deep. The fence is to be erected on the existing boundary line.

B4 DESCRIPTION OF WORK

B4.1 SETTING OUT AND EXCAVATION

The setting out of the work shall be the sole responsibility of the Contractor and shall be done in accordance with the "Guidelines for the provision of Engineering Services in Residential Townships" by The Department of Community Development.

Set out the work for the fence and spacing of the posts. Measure and mark a square area 600mm x 600mm to accommodate the post.

Excavate to the depth required (800mm minimum) for each post.

All work to be according to Betafence South Africa (Pty) Ltd Specifications.

All excavated material, and other surplus material or backfill shall be carted to and disposed of by the contractor at an approved dumpsite.

B4.2 CONCRETE FOUNDATIONS

Cast concrete to set post in an upright and plumb position with concrete foundations of 20 MPa using 19 mm stone.

B5 FENCE WORK

On the Left Hand Side from the Giel Basson Bridge to an existing wall opposite MP 15/4 - a distance of \pm 1133 metres. - Erect a 2.4 m high BETA fence along the existing Transnet boundary with a concrete plinth underneath of 200mm wide x 300mm deep. The fence is to be erected on the existing boundary line.

Total length of fence and plinth is 1133 m.

The extent of the work is according to Betafence South Africa (Pty) Ltd Specifications together with drawings **BE-ST-1 Snt 1 to 5**.

Top and bottom rails are required on all panels as per BETA specification.

B6 STANDARDS OF WORKMANSHIP

B6.1.1 The fence is to be neatly finished and is to be standing erect.

B6.1.2 All rough edges must be smoothed off.

B6.1 OVERALL STANDARD

B6.1.1 The overall standard to be achieved by the Contractor over the contract area, defined as "Overall Standard", will be determined visually by the Technical Officer

B6.1.2 The minimum percentage of the total work that shall comply with the standard, shall be 90%. This measurement will be applicable for each inspection carried out during the term of the contract.

B6.1.3 Failure by the Contractor to achieve the standard of "Overall Standard" shall enable the Project Manager to terminate the Contract.

B7 PERFORMANCE MONITORING, EVALUATION AND MEASUREMENT

- B7.1 The Contractor shall at all times be responsible for supervision of the work and for follow-up inspections. He/she shall immediately take appropriate remedial action in areas where the specified standards are not achieved.
- B7.2 The Technical Officer or his/her deputy shall at any time during the operation carry out inspections of the Contractor's performance methods and procedures. The Technical Officer may order the Contractor to re-do entire sections where necessary.
- B7.3 The Technical Officer or his/her deputy shall, during the contract period, carry out weekly inspections of the work for the purpose of measuring progress and evaluating whether standards, as defined, has been achieved.
- B7.3.1 During each of these inspections the progress of all completed work will be measured and evaluated. Any portion of the fence measured, which does not comply with the specified standard, will be recorded as rejected work.

All completed work must be recorded on an inspection sheet and produced to the Technical Officer or his duly authorised representative on the day of inspection. All such workmanship shall be to the satisfaction of the Technical Officer or his duly authorised representative.

- B7.4 Should, at any stage in the progress of the said works, or on completion, an inspection visit reveal any defects in the construction, all rejected work shall be rectified prior to the commencement of the work of following week by the **Contractor** at his own expense and to the satisfaction of the Technical Officer or his duly authorised representative.
- B7.5 In the case where the Technical Officer or his/her deputy and the Contractor fail to agree on rejected work, the rejected work shall be recorded as a "disputed work". The Contractor shall prepare an appropriate record of all disputed work in order that such disputes may be resolved by way of the disputes resolution procedures.
- B7.6 The Project Manager reserves the right to forego any inspection by giving the Contractor written notice of his/her intention to do so. Should the Project Manager decide to forego any inspection, he/she would thereby indicate that he/she is satisfied with the standard of workmanship required for that specific inspection only. He/she would then make full payment to the Contractor to the value associated with that inspection.
- The fact that the Project Manager may decide to forego any inspection at his/her discretion does not imply that further inspections would not be carried out. It only implies that for that inspection, the Project Manager is satisfied with the standard achieved and will not penalise the Contractor for that inspection.
- The Contractor shall at his cost make good to the satisfaction of the Technical Officer all defective material and workmanship which is not in accordance with the Contract and which may appear within a period of 2 weeks after the date stated in the CERTIFICATE OF COMPLETION, and shall repair all damage caused thereby.

B8 PROGRAMME OF WORK AND METHOD STATEMENT:

A detail work program and method statement must be submitted to the Technical Officer within 7 days of acceptance of the tender. The program must indicate the quantities, type of work to be performed, as well as other obligations and responsibilities pertaining to the **WORKS**. The program will be updated regularly and communicated to the Technical Officer. No extension of time claims will be considered without a proper work program.

B9 MEASUREMENT AND PAYMENT:

The BETA fence shall be measured and paid for per finished linear metre. Tendered rates must therefore include supply and delivery of all materials for the fence including the foundations. Site clearance, excavation, compaction, assembly, and all other activities necessary for the completion of the works are all to be included in tendered rates for the erection of the fence.

Payment for the work completed will be made upon receipt of an invoice from the Contractor.

TRANSNET



freight rail

TRANSNET LIMITED

(REGISTRATION NO.1990/000900/30)

Annexure C

SCHEDULE OF QUANTITIES AND PRICES / PRICE LIST

TRADING AS TRANSNET FREIGHT RAIL

**BLE52484 : UPGRADE TRANSNET BOUNDARY FENCE WITH BETA FENCE AT PAROW NORTH
FROM GIEL BASSON BRIDGE TO KM 15P4 ON THE LEFT HAND SIDE
(Opposite Parow Gholf Course).**

ITEM	DESCRIPTION	UNIT	Qty	RATE	AMOUNT
C1	Erect New BETA Fence	m	1133		
C2	Providing of 200 wide x 300mm deep plinth	m	1133		
C3	Clearing of site for 2m wide on the TTR Boundary	m	1133		
	TOTAL (Excluding VAT)				R

Price in Words

(Excluding VAT)

TRANSNET



freight rail

TRANSNET LIMITED

(REGISTRATION NO.1990/000900/30)

TRADING AS TRANSNET FREIGHT RAIL

Annexure D

**BLE52484 : UPGRADE TRANSNET BOUNDARY FENCE WITH BETA FENCE AT PAROW NORTH
FROM GIEL BASSON BRIDGE TO KM 15P4 ON THE LEFT HAND SIDE
(Opposite Parow Gholf Coarse).**

DRAWINGS

The following drawings are included :

BETA Fence -

BB STD-1 Sht 1 to 5



Transnet Supplier Declaration/Application

The Financial Director or Company Secretary

Transnet Vendor Management has received a request to load your company on to the Transnet vendor database. Please furnish us with the following to enable us to process this request:

1. Complete the "Supplier Declaration Form" (SDF) on page 2 of this letter
2. **Original** cancelled cheque **OR** letter from the bank verifying banking details (**with bank stamp**)
3. **Certified** copy of Identity document of Shareholders/Directors/Members (where applicable)
4. **Certified** copy of certificate of incorporation, CM29 / CM9 (name change)
5. **Certified** copy of share Certificates of Shareholders, CK1 / CK2 (if CC)
6. A letter with the company's letterhead confirming physical and postal addresses
7. **Original** or **certified** copy of SARS Tax Clearance certificate and Vat registration certificate
8. A signed letter from the Auditor / Accountant confirming most recent annual turnover and percentage black ownership in the company **AND/OR** BBBEE certificate and detailed scorecard from an accredited rating agency (SANAS member).

NB: • **Failure to submit the above documentation will delay the vendor creation process.**
 • Where applicable, the respective Transnet business unit processing your application may request further information from you. E.g. proof of an existence of a Service/Business contract between your business and the respective Transnet business unit etc.

IMPORTANT NOTES:

- a) If your annual turnover is less than R5 million, then in terms of the DTI codes, you are classified as an Exempted Micro Enterprise (EME). If your company is classified as an EME, please include in your submission, a signed letter from your Auditor / Accountant confirming your company's most recent annual turnover is less than R5 million and percentage of black ownership and black female ownership in the company **AND/OR** BBBEE certificate and detailed scorecard from an accredited rating agency (e.g. permanent SANAS Member), should you feel you will be able to attain a better BBBEE score.
- b) If your annual turnover is between R5 million and R35million, then in terms of the DTI codes, you are classified as a Qualifying Small Enterprise (QSE) and you claim a specific BBBEE level based on any 4 of the 7 elements of the BBBEE score-card, please include your BEE certificate in your submission as confirmation of your status.
NB: BBBEE certificate and detailed scorecard should be obtained from an accredited rating agency (e.g. permanent SANAS Member).
- c) If your annual turnover is in excess of R35million, then in terms of the DTI codes, you are classified as a Large Enterprise and you claim a specific BEE level based on all seven elements of the BBBEE generic score-card. Please include your BEE certificate in your submission as confirmation of your status.
NB: BBBEE certificate and detailed scorecard should be obtained from an accredited rating agency (permanent SANAS Member).
- d) To avoid PAYE tax being automatically deducted from any invoices received from you, you must also contact the Transnet person who lodged this request on your behalf, so as to be correctly classified in terms of tax legislation.
- e) Unfortunately, **No payments can be made to a vendor** until the vendor has been registered, and no vendor can be registered until the vendor application form, together with its supporting documentation, has been received and processed.
- f) **Please return the completed Supplier Declaration Form (SDF) together with the required supporting documents mentioned above to the Transnet Official who is intending to procure your company's services/products in order that he/she should complete and Internal Transnet Departmental Questionnaire before referring the matter to the appropriate Transnet Vendor Master Office.**

Regards,

Transnet Vendor/Supplier Management .Contact person Carol tell: 021 940-3846 fax 021 940-3883.



Supplier Declaration Form

Company Trading Name						
Company Registered Name						
Company Registration Number Or ID Number If A Sole Proprietor						
Form of entity	CC	Trust	Pty Ltd	Limited	Partnership	Sole Proprietor
VAT number (if registered)						
Company Telephone Number						
Company Fax Number						
Company E-Mail Address						
Company Website Address						
Bank Name			Bank Account Number			
Postal Address						Code
Physical Address						Code
Contact Person						
Designation						
Telephone						
Email						
Annual Turnover Range (Last Financial Year)		< R5 Million	R5-35 million	> R35 million		
Does Your Company Provide		Products	Services	Both		
Area Of Delivery		National	Provincial	Local		
Is Your Company A Public Or Private Entity			Public	Private		
Does Your Company Have A Tax Directive Or IRP30 Certificate			Yes	No		
Main Product Or Service Supplied (E.G.: Stationery/Consulting)						
BEE Ownership Details						
% Black Ownership		% Black women ownership		% Disabled person/s ownership		
Does your company have a BEE Certificate			Yes	No		
What is your broad based BEE status (Level 1 to 9 / Unknown)						
How many personnel does the firm employ			Permanent	Part time		
Transnet Contact Person						
Contact number						
Transnet operating division						
Duly Authorised To Sign For And On Behalf Of Firm / Organisation						
Name			Designation			
Signature			Date			
Stamp And Signature Of Commissioner Of Oath						
Name			Date			
Signature			Telephone No.			

NB: Please return the completed Supplier Declaration Form (SDF) together with the required supporting documents mentioned above to the Transnet Official who is intending to procure your company's services/products.

Transnet Vendor/Supplier Management .Contact person Carol tell: 021 940-3846 fax 021 940-3883

TRANSNET LIMITED

(Registration no. 1990/000900/30)

**SAFETY ARRANGEMENTS AND PROCEDURAL COMPLIANCE
WITH THE OCCUPATIONAL HEALTH AND SAFETY ACT
(ACT 85 OF 1993) AND APPLICABLE REGULATIONS****1. General**

- 1.1 The Contractor and Transnet Limited (hereinafter referred to as "Transnet") are individual employers, each in its own right, with their respective duties and obligations set out in the Occupational Health and Safety Act, Act 85 of 1993 (the Act) and applicable Regulations.
- 1.2 The Contractor accepts, in terms of the General Conditions of Contract and in terms of the Act, his obligations as an employer in respect of all persons in his employ, other persons on the premises or the Site or place of work or on the work to be executed by him, and under his control. He shall, before commencement with the execution of the contract work, comply with the provisions set out in the Act, and shall implement and maintain a Health and Safety Plan as described in the Construction Regulations, 2003 and as approved by Transnet, on the Site and place of work for the duration of the Contract.
- 1.3 The Contractor accepts his obligation to complying fully with the Act and applicable Regulations notwithstanding the omission of some of the provisions of the Act and the Regulations from this document.
- 1.4 Transnet accepts, in terms of the Act, its obligations as an employer of its own employees working on or associated with the site or place of work, and the Contractor and Technical Officer or his deputy shall at all times, co-operate in respect of the health and safety management of the site, and shall agree on the practical arrangements and procedures to be implemented and maintained during execution of the Works.
- 1.5 In the event of any discrepancies between any legislation and this specification, the applicable legislation will take precedence.

2. Definitions

- 2.1 In this Specification any word or expression to which a meaning has been assigned in the Construction Regulations, shall have the meaning so assigned to it, unless the context otherwise indicates: -
- 2.2 The work included in this Contract shall for the purposes of compliance with the Act be deemed to be "**Construction Work**", which, in terms of the Construction Regulations, 2003 means any work in connection with: -
- (a) the erection, maintenance, alteration, renovation, repair, demolition or dismantling of or addition to a building or any similar structure;

- (b) the installation, erection, dismantling or maintenance of fixed plant where such work includes the risk of a person falling;
 - (c) the construction, maintenance, demolition or dismantling of any bridge, dam, canal, road, railway, runway, sewer or water reticulation system or any similar civil engineering structure; or
 - (d) the moving of earth, clearing of land, the making of an excavation, piling, or any similar type of work;
- 2.3 **“competent person”** in relation to construction work, means any person having the knowledge, training and experience specific to the work or task being performed: Provided that where appropriate qualifications and training are registered as per the South African Qualifications Authority Act, 1995 these qualifications and training shall be deemed to be the required qualifications and training;
- 2.4 **“contractor”** means principal contractor and **“subcontractor”** means contractor as defined by the Construction Regulations, 2003.
- 2.5 **“fall protection plan”** means a documented plan of all risks relating to working from an elevated position, considering the nature of work undertaken, and setting out the procedures and methods applied to eliminate the risk;
- 2.6 **“health and safety file”** means a file, or other record in permanent form, containing the information required to be kept on site in accordance with the Act and applicable Regulations;
- 2.7 **“Health and Safety Plan”** means a documented plan which addresses the hazards identified and include safe work procedures to mitigate, reduce or control the hazards identified;
- 2.8 **“Risk Assessment”** means a programme to determine any risk associated with any hazard at a construction site, in order to identify the steps needed to be taken to remove, reduce or control such hazard;
- 2.9 **“the Act”** means the Occupational Health and Safety Act No. 85 of 1993.

3. **Procedural Compliance**

3.1 The Contractor who intends to carry out any construction work shall, before carrying out such work, notify the Provincial Director in writing if the construction work:-

- (a) includes the demolition of a structure exceeding a height of 3 metres; or
- (b) includes the use of explosives to perform construction work; or
- (c) includes the dismantling of fixed plant at a height greater than 3m,

and shall also notify the Provincial Director in writing when the construction work exceeds 30 days or will involve more than 300 person days of construction work and if the construction work:-

- (a) includes excavation work deeper than 1m; or

- (b) includes working at a height greater than 3 metres above ground or a landing.
- 3.2 The notification to the Provincial Director shall be on a form similar to Annexure A of the Construction Regulations, 2003, also shown in Annexure 1 of this Specification. The Contractor shall ensure that a copy of the completed notification form is kept on site for inspection by an inspector, Technical Officer or employee.
- 3.3 The Contractor shall, in accordance with the Act and applicable Regulations, make all the necessary appointments of competent persons in writing on a form similar to Annexure 2 of this Specification and deliver copies thereof to the Technical Officer. Copies should also be retained on the health and safety file.
- 3.4 Subcontractors shall also make the above written appointments and the Contractor shall deliver copies thereof to the Technical Officer.
- 3.5 In the case of a self-employed Contractor or any subcontractor who has the appropriate competencies and supervises the work himself, the appointment of a construction supervisor in terms of regulation 6.1 of the Construction Regulations, 2003 will not be necessary. The Contractor shall in such a case execute and sign a declaration, as in Annexure 3, by which he personally undertakes the duties and obligations of the "Chief Executive Officer" in terms of section 16(1) of the Act.
- 3.6 The Contractor shall, before commencing any work, obtain from the Technical Officer an access certificate as in Annexure 4 executed and signed by him, permitting and limiting access to the designated site or place of work by the Contractor and any subcontractors under his control.
- 3.7 Procedural compliance with Act and Regulations, as above, shall also apply to any subcontractors as employers in their own right. The Contractor shall furnish the Technical Officer with full particulars of such subcontractors and shall ensure that they comply with the Act and Regulations and Protekon's safety requirements and procedures.

4. Special Permits

Where special permits are required before work may be carried out such as for hotwork, isolation permits, work permits and occupations, the Contractor shall apply to the Technical Officer or the relevant authority for such permits to be issued. The Contractor shall strictly comply with the conditions and requirements pertaining to the issue of such permits.

5. Health and Safety Programme

- 5.1 The Tenderer shall, with his tender, submit a Health and Safety Programme setting out the practical arrangements and procedures to be implemented by him to ensure compliance by him with the Act and Regulations and particularly in respect of: -
- (i) The provision, as far as is reasonably practical, of a working environment that is safe and without risk to the health of his employees and subcontractors in terms of section 8 of the Act;

- (ii) the execution of the contract work in such a manner as to ensure in terms of section 9 of the Act that persons other than those in the Contractor's employment, who may be directly affected by the contract work are not thereby exposed to hazards to their health and safety;
 - (iii) ensuring, as far as is reasonably practical, in terms of section 37 of the Act that no employee or subcontractor of the Contractor does or omits to do any act which would be an offence for the Contractor to do or omit to do.
- 5.2 The Contractor's Health and Safety Programme shall be based on a risk assessment in respect of the hazards to health and safety of his employees and other persons under his control that are associated with or directly affected by the Contractor's activities in performing the contract work and shall establish precautionary measures as are reasonable and practical in protecting the safety and health of such employees and persons.
- 5.3 The Contractor shall cause a risk assessment contemplated in clause 5.2 above to be performed by a competent person, appointed in writing, before commencement of any Construction Work and reviewed during construction. The Risk Assessments shall form part of the Health and Safety programme to be applied on the site and shall include at least the following:
- (a) The identification of the risks and hazards that persons may be exposed to;
 - (b) the analysis and evaluation of the hazards identified;
 - (c) a documented Health and Safety Plan, including safe work procedures to mitigate, reduce or control the risks identified;
 - (d) a monitoring and review plan.
- 5.4 The Health and Safety Plan shall include full particulars in respect of: -
- (a) The safety management structure to be instituted on site or place of work and the names of the Contractor's health and safety representatives and members of safety committees where applicable;
 - (b) the safe working methods and procedures to be implemented to ensure the work is performed in compliance with the Act and Regulations;
 - (c) the safety equipment, devices and clothing to be made available by the Contractor to his employees;
 - (d) the site access control measures pertaining to health and safety to be implemented;
 - (e) the arrangements in respect of communication of health and safety related matters and incidents between the Contractor, his employees, subcontractors and the Technical Officer with particular reference to the reporting of incidents in compliance with Section 24 and General Administrative Regulation 8 of the Act and with the pertinent clause of the General Conditions of Contract forming part of the Contract and

- (f) the introduction of control measures for ensuring that the Safety Plan is maintained and monitored for the duration of the Contract.
- 5.4 The Health and Safety programme shall be subject to the Technical Officer's approval and he may, in consultation with the Contractor, order that additional and/or supplementary practical arrangements and procedures be implemented and maintained by the Contractor or that different working methods or safety equipment be used or safety clothes be issued which, in the Technical Officer's opinion, are necessary to ensure full compliance by the Contractor with his obligations as an employer in terms of the Act and Regulations. The Technical Officer or his deputy shall be allowed to attend meetings of the Contractor's safety committee as an observer.
- 5.5 The Contractor shall take reasonable steps to ensure that each subcontractor's Health and Safety Plan is implemented and maintained on the construction site: Provided that the steps taken, shall include periodic audits at intervals mutually agreed to between the them, but at least once every month.
- 5.6 The Contractor shall stop any subcontractor from executing any construction work, which is not in accordance with the Contractor's, and/or subcontractor's Health and Safety Plan for the site or which poses a threat to the health and safety of persons.
- 5.7 The Contractor shall ensure that a copy of the Health and Safety Plan is available on site for inspection by an inspector, Technical Officer, agent, subcontractor, employee, registered employee organisation, health and safety representative or any member of the health and safety committee.
- 5.8 The Contractor shall consult with the health and safety committee or, if no health and safety committee exists, with a representative group of employees, on the development, monitoring and review of the Risk Assessment.
- 5.9 The Contractor shall ensure that all employees under his control are informed, instructed and trained by a competent person regarding any hazard and the related work procedures before any work commences, and thereafter at such times as may be determined in the Risk Assessment.
- 5.10 The Contractor shall ensure that all subcontractors are informed regarding any hazard as stipulated in the Risk Assessment before any work commences, and thereafter at such times as may be determined in the Risk Assessment.
- 5.11 The Contractor shall ensure that all visitors to a construction site undergoes health and safety induction pertaining to the hazards prevalent on the site and shall be provided with the necessary personal protective equipment.
- 6. Fall Protection Plan**
- 6.1 In the event of the risk and hazard identification, as required in terms of clause 5.3 of this Specification, revealing risks relating to working from an elevated position the contractor shall cause the designation of a competent person, responsible for the preparation of a fall protection plan;

6.2 The Contractor shall implement, maintain and monitor the fall protection plan for the duration of Contract. The Contractor shall also take such steps to ensure the continued adherence to the fall protection plan.

6.3 The fall protection plan shall include:-

- (a) A Risk Assessment of all work carried out from an elevated position;
- (b) the procedures and methods to address all the identified risks per location;
- (c) the evaluation of the employees physical and psychological fitness necessary to work at elevated positions;
- (d) the training of employees working from elevated positions; and
- (e) the procedure addressing the inspection, testing and maintenance of all fall protection equipment.

7. Hazards and Potential Hazardous Situations

The Contractor and the Technical Officer shall immediately notify one another of any hazardous or potentially hazardous situations which may arise during performance of the Contract by the Contractor or any subcontractor and, in particular, of such hazards as may be caused by the design, execution and/or location and any other aspect pertaining to the contract work.

8. Health and Safety File

- 8.1 The Contractor shall ensure that a health and safety file is opened and kept on site and shall include all documentation required as per the Act and applicable regulations, and made available to an inspector, the Technical Officer, or subcontractor upon request.
- 8.2 The Contractor shall ensure that a copy of the both his Health and Safety Plan as well as any subcontractor's Health and Safety Plan is available on request to an employee, inspector, contractor or the Technical Officer.
- 8.3 The Contractor shall hand over a consolidated health and safety file to the Technical Officer upon completion of the Construction Work and shall in addition to documentation mentioned in the Act and applicable Regulations include a record of all drawings, designs, materials used and other similar information concerning the completed structure.

ANNEXURE 1**OCCUPATIONAL HEALTH AND SAFETY ACT, 1993****Regulation 3(1) of the Construction Regulations****NOTIFICATION OF CONSTRUCTION WORK**

-
-
- 1(a) Name and postal address of principal contractor:

- (b) Name and tel. no of principal contractor's contact person:

2. Principal contractor's compensation registration number: _____
- 3.(a) Name and postal address of client:

- (b) Name and tel no of client's contact person or agent:

- 4.(a) Name and postal address of designer(s) for the project:

- (b) Name and tel. no of designer(s) contact person:

5. Name and telephone number of principal contractor's construction supervisor on site appointed in terms of regulation 6(1).

6. Name(s) of principal contractor's construction sub-ordinate supervisors on site appointed in terms of regulation 6(2).

7. Exact physical address of the construction site or site office:

8. Nature of the construction work:

9. Expected commencement date: _____
10. Expected completion date: _____

11. Estimated maximum number of persons on the construction site: _____

12. Planned number of contractors on the construction site accountable to the principle contractor:

13. Name(s) of contractors already chosen.

Principal Contractor

Date

Client

Date

* THIS DOCUMENT IS TO BE FORWARDED TO THE OFFICE OF THE DEPARTMENT OF LABOUR PRIOR TO COMMENCEMENT OF WORK ON SITE.

* ALL PRINCIPAL CONTRACTORS THAT QUALIFY TO NOTIFY MUST DO SO EVEN IF ANOTHER PRINCIPAL CONTRACTOR ON THE SAME SITE HAD DONE SO PRIOR TO THE COMMENCEMENT OF WORK.

"PREVIEW COPY ONLY"

ANNEXURE 2

(COMPANY LETTER HEAD)

OCCUPATIONAL HEALTH AND SAFETY ACT, 1993 (ACT 85 OF 1993) :

SECTION/REGULATION: _____

REQUIRED COMPETENCY: _____

In terms of _____ I, _____

representing the Employer) do hereby appoint _____

As the Competent Person on the premises at _____

(physical address) to assist in compliance with the Act and the applicable Regulations.

Your designated area/s is/are as follows :-

Date : _____

Signature :- _____

Designation :- _____

"PREVIEW COPY ONLY"

ACCEPTANCE OF DESIGNATION

I, _____ do hereby accept this Designation and acknowledge that I understand the requirements of this appointment.

Date : _____

Signature :- _____

Designation :- _____

ANNEXURE 3**(COMPANY LETTER HEAD)****OCCUPATIONAL HEALTH AND SAFETY ACT, 1993 (ACT 85 OF 1993) :****DECLARATION**

In terms of the above Act I, _____ am personally assuming the duties and obligations as Chief Executive Officer, defined in Section 1 of the Act and in terms of Section 16(1), I will, as far as is reasonably practicable, ensure that the duties and obligations of the Employer as contemplated in the above Act are properly discharged.

Signature :- _____

Date : _____

"PREVIEW COPY ONLY"

ANNEXURE 4

(LETTER HEAD OF BUSINESS DIVISION OR UNIT OF TRANSNET LIMITED)

SITE ACCESS CERTIFICATE

Access to : _____ (Area)
Name of Contractor/Builder :- _____
Contract/Order No.: _____

The contract works site/area described above are made available to you for the carrying out of associated works
In terms of your contract/order with
(company) _____

Kindly note that you are at all times responsible for the control and safety of the Works Site, and for persons under your control having access to the site.

As from the date hereof you will be responsible for compliance with the requirements of the Occupational Health and Safety Act, 1993 (Act 85 of 1993) as amended, and all conditions of the Contract pertaining to the site of the works as defined and demarcated in the contract documents including the plans of the site or work areas forming part thereof.

Signed : _____ Date : _____
TECHNICAL OFFICER

"PREVIEW COPY ONLY"

ACKNOWLEDGEMENT OF RECEIPT

Name of Contractor/Builder :- _____ I,
_____ do hereby acknowledge and accept the duties
and obligations in respect of the Safety of the site/area of Work in terms of the Occupational Health and
Safety Act; Act 85 of 1993.

Name : _____ Designation : _____

Signature : _____ Date : _____

TRANSNET

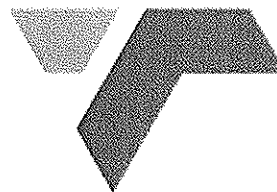

Transnet SOC Limited Registration Number 1990/00900/06

TRANSNET SPECIFICATION

**E7/1 - SPECIFICATION FOR GENERAL WORK AND
WORKS ON, OVER, UNDER OR ADJACENT TO RAILWAY
LINES AND NEAR HIGH VOLTAGE EQUIPMENT**

(This specification shall be used in network operator contracts)







"PREVIEW COPY ONLY"

Circulation Not Restricted

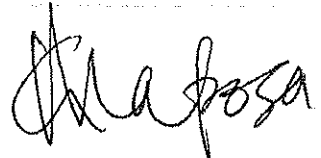
© This document as a whole is protected by copyright. The information herein is the sole property of Transnet SOC Ltd. It may not be used, disclosed or reproduced in part or in whole in any manner whatsoever, except with the written permission of and in a manner permitted by the proprietors.

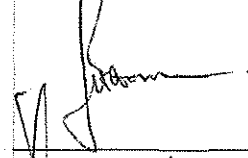
(This page not to be issued with contract)

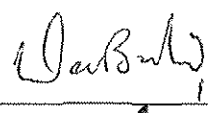
**SPECIFICATION FOR GENERAL WORK AND WORKS ON, OVER, UNDER OR
ADJACENT TO RAILWAY LINES AND NEAR HIGH VOLTAGE EQUIPMENT**

Author:	Project Manager Capital Program (Electrical)	G. Maposa	
Approved:	Senior Engineer Infra Engineering (Train Authorisation Systems)	J. van den Berg	
"	Principal Engineer Infra Engineering (Track)	M. Marutla	
"	Principal Engineer Infra Engineering (Structures)	J. Honan	
"	Principal Engineer Infra Engineering (Electrical)	J. Vosloo	
"	Principal Engineer Technology Management (Electrical)	W. Coetzee	
"	Chief Engineer Transport Telecoms	D. Botha	 17 June 11
Authorised:	Chief Engineer Infrastructure Engineering	J. van Aardt	 2011/06/30

Date: May 2011

(This page not to be issued with contract)

TRANSNET

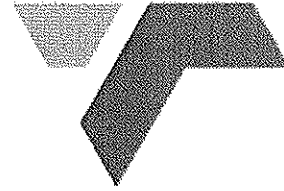

Transnet SOC Limited Registration Number 1990/00900/06

TRANSNET SPECIFICATION

**E7/1 - SPECIFICATION FOR GENERAL WORK AND
WORKS ON, OVER, UNDER OR ADJACENT TO RAILWAY
LINES AND NEAR HIGH VOLTAGE EQUIPMENT**

(This specification shall be used in network operator contracts)

"PREVIEW COPY ONLY"

Circulation Not Restricted

© This document as a whole is protected by copyright. The information herein is the sole property of Transnet SOC Ltd. It may not be used, disclosed or reproduced in part or in whole in any manner whatsoever, except with the written permission of and in a manner permitted by the proprietors.

CONTENTS		
<u>CLAUSE</u>	<u>HEADING</u>	<u>PAGE</u>
1.0	SCOPE	3
2.0	DEFINITIONS	3
PART A - GENERAL SPECIFICATION		
3.0	AUTHORITY OF OFFICERS OF TRANSNET	4
4.0	CONTRACTOR'S REPRESENTATIVES AND STAFF	4
5.0	OCCUPATIONS AND WORK PERMITS	4
6.0	SPEED RESTRICTIONS AND PROTECTION	5
7.0	ROADS ON THE NETWORK OPERATOR'S PROPERTY	5
8.0	CLEARANCES	5
9.0	STACKING OF MATERIAL	5
10.0	EXCAVATION, SHORING, DEWATERING AND DRAINAGE	5
11.0	FALSEWORK FOR STRUCTURES	6
12.0	PILING	6
13.0	UNDERGROUND SERVICES	6
14.0	BLASTING AND USE OF EXPLOSIVES	6
15.0	RAIL TROLLEYS	7
16.0	SIGNAL TRACK CIRCUITS	7
17.0	PENALTY FOR DELAYS TO TRAINS	7
18.0	SURVEY BEACONS AND PEGS	7
19.0	TEMPORARY LEVEL CROSSINGS	8
20.0	COMPLETION OF THE WORKS	8
21.0	PROTECTION OF PERSONS AND PROPERTY	9
22.0	INTERFERENCE WITH THE NETWORK OPERATOR'S ASSETS AND WORK ON OPEN LINES	10
23.0	ACCESS, RIGHTS OF-WAY AND CAMPSITES	10
24.0	SUPERVISION	10
25.0	HOUSING OF EMPLOYEES	10
26.0	OPTICAL FIBRE CABLE ROUTES	10
PART B - ADDITIONAL SPECIFICATION FOR WORK NEAR HIGH-VOLTAGE ELECTRICAL EQUIPMENT		
27.0	GENERAL	11
28.0	WORK ON BUILDINGS OR FIXED STRUCTURES	11
29.0	WORK DONE ON OR OUTSIDE OF ROLLING STOCK, INCLUDING LOADING AND UNLOADING	11
30.0	USE OF EQUIPMENT	12
31.0	CARRYING AND HANDLING MATERIAL AND EQUIPMENT	12
32.0	PRECAUTIONS TO BE TAKEN WHEN ERECTING OR REMOVING POLES, ANTENNAE AND TREES ETC.	12
33.0	USE OF WATER	13
34.0	USE OF CONSTRUCTION PLANT	13
35.0	WORK PERFORMED UNDER DEAD CONDITIONS UNDER COVER OF A WORK PERMIT	13
36.0	TRACTION RETURN CIRCUITS IN RAILS	13
37.0	HIGH-VOLTAGE ELECTRICAL EQUIPMENT NOT MAINTAINED AND/OR OPERATED BY THE NETWORK OPERATOR	14

1.0 SCOPE

- 1.1 This specification covers the network operator's requirements for general work and works on, over, under or adjacent to railway lines and near high voltage equipment.

2.0 DEFINITIONS

The following definitions shall apply:

"Authorised Person" - A person whether an employee of the network operator or not, who has been specially authorised to undertake specific duties in terms of Transnet' publication Electrical Safety Instructions, and who holds a certificate or letter of authority to that effect.

"Barrier" Any device designed to restrict access to "live" high-voltage electrical equipment.

"Bond" - A short conductor installed to provide electrical continuity.

"Contractor" - Any person or organisation appointed by the network operator to carry out work on its behalf.

"Contract Supervisor" - The person or juristic person appointed by the network operator from time to time as the Contract Supervisor, to administer the Contractor's performance and execution of the Works according to the powers and rights held by and obligations placed upon the Contract Supervisor in terms of the Contract.

"Dead" - Isolated and earthed.

"Electrical Officer (Contracts)" - The person appointed in writing by the Project Manager in terms of this specification as the person who shall be consulted by the Contractor in all electrical matters to ensure that adequate safety precautions are taken by the Contractor.

"Executive Officer" - The person appointed by the network operator from time to time as the Executive Officer to act according to the rights and powers held by and obligations placed upon him in terms of the Contract.

"High-Voltage" - A voltage normally exceeding 1000 volts.

"Live" - A conductor is said to be "live" when it is at a potential different from that of the earth or any other conductor of the system of which it forms a part.

"Near" - To be in such a position that a person's body or the tools he is using or any equipment he is handling may come within 2 metres of "live" exposed high-voltage electrical equipment.

"Occupation" - An authorisation granted by the network operator for work to be carried out under specified conditions on, over, under or adjacent to railway lines.

"Occupation Between Trains" - An occupation during an interval between successive trains.

"Optical Fibre Cable" - Buried or suspended composite cable containing optical fibres used in:

- telecommunication networks for transmission of digital information and
- safety sensitive train operations systems.

"Project Manager" - As defined in the special conditions of the contract. The person or juristic person appointed by the network operator from time to time as the Project Manager, to administer the Contract according to the powers and rights held by and obligations placed upon him in terms of the Contract.

"Responsible Representative" - The responsible person in charge, appointed by a contractor, who has undergone specific training (and holds a certificate) to supervise (general or direct) staff under his control who perform general work or to work on, over, under or adjacent to railway lines and in the vicinity of high-voltage electrical equipment.

"Total Occupation" - An occupation for a period when trains are not to traverse the section of line covered by the occupation.

"Work on" - Work undertaken on or so close to the equipment that the specified working clearances to the "live" equipment cannot be maintained.

"Work Permit" - A combined written application and authority to proceed with work on or near dead electrical equipment.

"Works" - The contractual intent for the work to be done as defined in the contract at a defined work site.

PART A - GENERAL SPECIFICATION**3.0 AUTHORITY OF OFFICERS OF TRANSNET**

- 3.1 The Contractor shall co-operate with the officers of the network operator and shall comply with all instructions issued and restrictions imposed with respect to the Works which bear on the existence and operation of the network operator's railway lines and high-voltage equipment.
- 3.2 Without limiting the generality of the provisions of clause 3.1, any duly authorised representative of the network operator, having identified himself, may stop the work if, in his opinion, the safe passage of trains or the safety of the network operator's assets or any person is affected. **CONSIDERATIONS OF SAFETY SHALL TAKE PRECEDENCE OVER ALL OTHER CONSIDERATIONS.**

4.0 CONTRACTOR'S REPRESENTATIVES AND STAFF

- 4.1 The Contractor shall nominate Responsible Representatives of whom at least one shall be available at any hour for call-out in cases of emergency. The Contractor shall provide the Contract Supervisor with the names, addresses and telephone numbers of the representatives.
- 4.2 The Contractor guarantees that he has satisfied himself that the Responsible Representative is fully conversant with this specification and that he shall comply with all his obligations in respect thereof.
- 4.3 The Contractor shall ensure that all contractor staff receives relevant awareness, educational and competence training regarding safety as prescribed.

5.0 OCCUPATIONS AND WORK PERMITS

- 5.1 Work to be done during total occupation or during an occupation between trains or under a work permit shall be done in a manner decided by the Contract Supervisor and at times to suit the network operator requirements.
- 5.2 The Contractor shall organise the Works in a manner which will minimise the number and duration of occupations and work permits required.
- 5.3 The network operator will not be liable for any financial or other loss suffered by the Contractor arising from his failure to complete any work scheduled during the period of an occupation or work permit.
- 5.4 The Contractor shall submit to the Contract Supervisor, in writing, requests for occupations or work permits together with details of the work to be undertaken, at least 21 days before they are required. The network operator does not undertake to grant an occupation or work permit for any particular date, time or duration.
- 5.5 The network operator reserves the right to cancel any occupation or work permit at any time before or during the period of occupation or work permit. If, due to cancellation or change in date or time, the Contractor is not permitted to start work under conditions of total occupation or work permit at the time arranged, all costs caused by the cancellation shall be born by the Contractor except as provided for in clauses 5.6 to 5.8.
- 5.6 When the Contractor is notified less than 2 hours before the scheduled starting time that the occupation or work permit is cancelled, he may claim reimbursement of his direct financial losses caused by the loss of working time up to the time his labour and plant are employed on other work, but not exceeding the period of the cancelled occupation or work permit.
- 5.7 When the Contractor is notified less than 2 hours before the scheduled starting time, or during an occupation or work permit, that the duration of the occupation or work permit is reduced, he may claim reimbursement of his direct financial losses caused by the loss of working time due to the reduced duration of the occupation or work permit.
- 5.8 Reimbursement of the Contractor for any loss of working time in terms of clause 5.6 and 5.7, shall be subject to his claims being submitted within 14 days of the event with full details of labour and plant involved, and provided that the Contract Supervisor certifies that no other work on which the labour and plant could be employed was immediately available.
- 5.9 Before starting any work for which an occupation has been arranged, the Contractor shall obtain from the Contract Supervisor written confirmation of the date, time and duration of the occupation.
- 5.10 Before starting any work for which a work permit has been arranged, the Responsible Representative shall read and sign portion C of the Work Permit, signifying that he is aware of the work boundaries within which work may be undertaken. After the work for which the permit was granted has been completed, or when the

work permit is due to be terminated, or if the permit is cancelled after the start, the same person who signed portion C shall sign portion D of the Work Permit, thereby acknowledging that he is aware that the electrical equipment is to be made "live". The Contractor shall advise all his workmen accordingly.

6.0 SPEED RESTRICTIONS AND PROTECTION

6.1 When speed restrictions are imposed by the network operator because of the Contractor's activities, the Contractor shall organise and carry out his work so as to permit the removal of the restrictions as soon as possible.

6.2 When the Contract Supervisor considers protection to be necessary the Contractor shall, unless otherwise agreed, provide all protection including flagmen, other personnel and all equipment for the protection of the network operator's and the Contractor's personnel and assets, the public and including trains.

6.2.1 The network operator will provide training free of charge of the Contractor's flagmen and other personnel performing protection duties. The Contractor shall consult with the Contract Supervisor, whenever he considers that protection will be necessary, taking into account the minimum permissible clearances set out in the Manual for Track Maintenance (Document no. BBB0481):

- Drawing no. BE-97 Sheet 1: Horizontal Clearances: 1065mm gauge (Annexure 1 sheet 1)
- Drawing no. BE-97 Sheet 2: Vertical Clearances: 1065mm gauge (Annexure 1 sheet 2)
- Drawing no. BE-97 Sheet 3: Clearances: Platform (Annexure 1 sheet 3)
- Drawing no. BE-97 Sheet 5: Clearances: 610mm Gauge (Annexure 1 sheet 5)

6.3 The Contractor shall appoint a Responsible Representative to receive and transmit any instruction which may be given by the network operator personnel providing protection.

7.0 ROADS AND ROADS ON THE NETWORK OPERATOR'S PROPERTY

7.1 The Contractor shall take every reasonable precaution to prevent damage to any roads or bridges used to obtain access to the site, and shall select routes, use vehicles, and restrict loads so that any extraordinary traffic as may arise from the moving of plant or material to or from the site shall be limited as far as is reasonably possible.

7.2 The Contractor shall not occupy or interfere in any way with the free use of any public or private road, right-of-way, path or street unless the Contract Supervisor has obtained the approval of the road authority concerned.

8.0 CLEARANCES

8.1 No temporary works shall encroach on the appropriate minimum clearances set out in the Manual for Track Maintenance (Document no. BBB0481):

- Drawing no. BE-97 Sheet 1: Horizontal Clearances: 1065mm gauge (Annexure 1 sheet 1)
- Drawing no. BE-97 Sheet 2: Vertical Clearances: 1065mm gauge (Annexure 1 sheet 2)
- Drawing no. BE-97 Sheet 3: Clearances: Platform (Annexure 1 sheet 3)
- Drawing no. BE-97 Sheet 5: Clearances: 610mm Gauge (Annexure 1 sheet 5)

9.0 STACKING OF MATERIAL

9.1 The Contractor shall not stack any material closer than 3m from the centre line of any railway line without prior approval of the Contract Supervisor.

10.0 EXCAVATION, SHORING, DEWATERING AND DRAINAGE

10.1 Unless otherwise approved by the Contract Supervisor any excavation adjacent to a railway line shall not encroach on the hatched area shown in Figure 1.

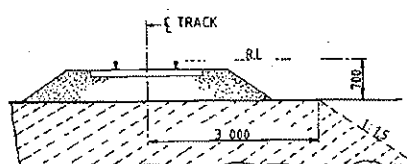

Fig. 1

- 10.2 The Contractor shall provide, at his own cost any shoring, dewatering or drainage of any excavation unless otherwise stipulated elsewhere in the Contract.
- 10.3 Where required by the Contract Supervisor, drawings of shoring for any excavation under or adjacent to a railway line shall be submitted and permission to proceed, obtained before the excavation is commenced.
- 10.4 The Contractor shall prevent ingress of water to the excavation but where water does enter, he shall dispose of it as directed by the Contract Supervisor.
- 10.5 The Contractor shall not block, obstruct or damage any existing drains either above or below ground level unless he has made adequate prior arrangements to deal with drainage.

11.0 FALSEWORK FOR STRUCTURES

- 11.1 Drawings of falsework for the construction of any structure over, under or adjacent to any railway line shall be submitted to the Contract Supervisor and his permission to proceed obtained before the falsework is erected. Each drawing shall be given a title and a distinguishing number and shall be signed by a registered professional engineer certifying that he has checked the design of the falsework and that the drawings are correct and in accordance with the design.
- 11.2 After the falsework has been erected and before any load is applied, the Contractor shall submit to the Contract Supervisor a certificate signed by a registered professional engineer certifying that he has checked the falsework and that it has been erected in accordance with the drawings. Titles and numbers of the drawings shall be stated in the certificate. Notwithstanding permission given by the Contract Supervisor to proceed, the Contractor shall be entirely responsible for the safety and adequacy of the falsework.

12.0 PILING

- 12.1 The Contract Supervisor will specify the conditions under which piles may be installed on the network operator's property.

13.0 UNDERGROUND SERVICES

- 13.1 No pegs or stakes shall be driven or any excavation made before the Contractor has established that there are no underground services which may be damaged thereby.
- 13.2 Any damage shall be reported immediately to the Contract Supervisor, or to the official in charge at the nearest station, or to the traffic controller in the case of centralised traffic control.

14.0 BLASTING AND USE OF EXPLOSIVES

- 14.1 When blasting within 500m of a railway line, the Contractor shall observe the requirements stipulated in this specification.
- 14.2 No blasting shall be carried out except with the prior written permission of the Contract Supervisor and under such conditions as he may impose.
- 14.3 On electrified lines the Contractor shall also obtain the permission of the Electrical Officer (Contracts) before blasting and shall give at least 21 days notice of his intention to blast. No blasting shall be done in the vicinity of electrified lines unless a member of the network operator's electrical personnel is present.
- 14.4 The Contractor shall arrange for the supply, transport storage and use of explosives.
- 14.5 The Contractor shall have labour, tools and plant, to the satisfaction of the Contract Supervisor, available on the site to clear immediately any stones or debris deposited on the track or formation by blasting, and to repair any damage to the track or formation immediately after blasting. Repairs to the track shall be carried out only under the supervision of a duly authorised representative of the network operator.
- 14.6 The Contractor shall notify the Contract Supervisor of his intention to blast at least 21 days before the commencement of any blasting operations.
- 14.7 Before any blasting is undertaken, the Contractor and the Contract Supervisor shall jointly examine and measure up any buildings, houses or structures in the vicinity of the proposed blasting to establish the extent of any existing cracking or damage to such structures, etc. The Contractor, shall, subject to the provisions stipulated in the Contract Insurance Policy, make good any deterioration of such buildings, houses, or structures, which, in the opinion of the Contract Supervisor, was directly caused by the blasting.
- 14.8 After completion of the blasting the Contractor shall obtain a written clearance from each landowner in

the vicinity of the blasting operations to the effect that all claims for compensation in respect of damage caused by the blasting operations to their respective properties, have been settled.

14.9 The Contractor shall provide proof that he has complied with the provisions of clauses 10.17.1 to 10.17.4 of the Explosives Regulations (Act 26 of 1956 as amended).

14.10 Blasting within 500m of a railway line will only be permitted during intervals between trains. A person appointed by the Contract Supervisor, assisted by flagmen with the necessary protective equipment, will be in communication with the controlling railway station.

Only this person will be authorised to give the Contractor permission to blast, and the Contractor shall obey his instructions implicitly regarding the time during which blasting may take place.

14.11 The flagmen described in clause 14.10, where provided by the network operator, are for the protection of trains and the network operator's property only, and their presence does not relieve the Contractor in any manner of his responsibilities in terms of Explosives Act or Regulations, or any obligation in terms of this Contract.

14.12 The person described in clause 14.10 will record in a book provided and retained by the network operator, the dates and times:-

(i) when each request is made by him to the controlling station for permission to blast;

(ii) when blasting may take place;

(iii) when blasting actually takes place; and

(iv) when he advises the controlling station that the line is safe for the passage of trains.

14.13 Before each blast the Contractor shall record in the same book, the details of the blast to be carried out. The person appointed by the Contract Supervisor and the person who will do the blasting shall both sign the book whenever an entry described in clause 14.12 is made.

15.0 RAIL TROLLEYS

15.1 The use of rail trolleys or trestle trolleys on a railway line for working on high voltage equipment will be permitted only if approved by the Contract Supervisor and under the conditions stipulated by him.

15.2 All costs in connection with trolley working and any train protection services requested by the Contractor shall, be borne by the Contractor, unless otherwise agreed.

16.0 SIGNAL TRACK CIRCUITS

16.1 Where signal track circuits are installed, the Contractor shall ensure that no material capable of conducting an electrical current makes contact between rails of railway line/lines.

16.2 No signal connections on track-circuited tracks shall be severed without the Contract Supervisor's knowledge and consent.

17.0 PENALTY FOR DELAYS TO TRAINS

17.1 If any trains are delayed by the Contractor and the Contract Supervisor is satisfied that the delay was avoidable, a penalty will be imposed on the Contractor as stipulated in the contract, for the period and number of trains delayed.

18.0 SURVEY BEACONS AND PEGS

18.1 The Contractor shall not on any account move or damage any beacon, bench mark, reference mark, signal or trigonometrical station in the execution of the Works without the written approval of the Contract Supervisor.

Should the Contractor be responsible for any such occurrence, he shall report the circumstances to the Contract Supervisor who will arrange with the Director-General of Surveys for replacement of the beacon or mark at the cost of the Contractor.

18.2 The Contractor shall not move or damage any cadastral or mining beacon without the written approval of the Contract Supervisor and before it has been referenced by a registered land surveyor. Any old boundary beacon, which becomes an internal beacon on creation of new boundaries, shall not be moved without the written approval of the Contract Supervisor.

Should the Contractor move or damage any cadastral or mining beacon without authority, he shall be responsible for having it replaced, at his cost, by a land surveyor.

- 18.3 The Contractor shall preserve all pegs and bench marks. Such survey points shall not be removed without the written approval of the Contract Supervisor. Should any peg or benchmark be removed without authority, the Contract Supervisor will arrange for its replacement and the cost will be recovered from the Contractor. No claim will be considered for delay in replacing any such peg or bench mark. Each peg replaced shall be checked by the Contractor.
- 18.4 Where a new boundary has been established, beacons on the fence line shall not be disturbed, and fence posts or anchors may not be placed or excavations made within 0,6 m of any beacon without the prior written approval of the Contract Supervisor.

19.0 TEMPORARY LEVEL CROSSINGS

- 19.1 The Contract Supervisor may, on request of the Contractor, and if necessary for the purpose of execution of the Works, permit the construction of a temporary level crossing over a railway a line at a position approved by the Contract Supervisor and at the Contractor's cost. The period for which the temporary level crossing is permitted will be at the discretion of the Contract Supervisor.

- 19.2 The Contractor will provide protection and supervise the construction of the road over the track(s) and within the railway servitude at the level crossing, as well as the erection of all road signs and height gauges. All cost to be borne by the applicant.

The Contractor shall exercise extreme caution in carrying out the work, especially in respect of damage to tracks, services, overhead power and communications routes and prevent contact with "live" overhead electrical equipment.

Unless otherwise agreed, the Contractor will provide the service deviations or alterations to the network operator's track-, structure-, drainage-, electrical-, tele-communications- and train authorisation systems to accommodate the level crossing.

- 19.3 The Contractor shall take all necessary steps including the provision of gates, locks and, where necessary, watchmen to restrict the use of the temporary level crossing to himself and his employees, his subcontractors and their employees, the staff of the network operator and to such other persons as the Contract Supervisor may permit and of whose identity the Contractor will be advised. If so ordered by the Contract Supervisor, the Contractor shall provide persons to control road traffic using the temporary level crossing. Such persons shall stop all road traffic when any approaching train is within seven hundred and fifty (750) metres of the temporary level crossing, and shall not allow road traffic to proceed over it until the lines are clear.
- 19.4 The Contractor shall maintain the temporary level crossing within the railway servitude in good condition for the period it is in use. A temporary agreement with the road authority to be concluded for the maintenance of the level crossing outside the railway servitude.
- 19.5 When the temporary level crossing is no longer required by the Contractor, or permitted by the network operator, the Contractor shall at his own cost remove it and restore the site and the network operator's track-, structure-, drainage-, electrical-, tele-communications- and train authorisation systems to its original condition. Work over the tracks and within the railway servitude will be supervised by the network operator.

20.0 COMPLETION OF THE WORKS

- 20.1 On completion of the works, the Contractor shall remove all the remaining construction plant and material from the site, other than material which is the property of the network operator, and leave the site in a clean, neat and tidy condition. If material and plant is required for the liability and maintenance period the Contract supervisor must authorise its retention on site.

21.0 PROTECTION OF PERSONS AND PROPERTY

- 21.1 The Contractor shall provide and maintain all lights, guards, barriers, fencing and watchmen when and where necessary or as required by the Contract Supervisor or by any statutory authority, for the protection of the Works and for the safety and convenience of the public.

Red, yellow, green or blue lights may not be used by the Contractor as they can be mistaken for signals. Red, yellow, green or white flags shall only be used for protection by the Contractor. Within the precincts of a port the Contractor shall obtain the permission of the Port Captain before installing any light.

- 21.2 The Contractor shall take all the requisite measures and precautions during the course of the Works to:
- (i) protect the public and property of the public,
 - (ii) protect the property and workmen of both the network operator and the Contractor,
 - (iii) avoid damage to and prevent trespass on adjoining properties, and
 - (iv) ensure compliance with any instruction issued by the Contract Supervisor or other authorised person, and with any stipulation embodied in the contract documents which affects the safety of any person or thing.
- 21.3 The network operator will provide, at its own cost, protection for the safe working of trains during such operations as the Contract Supervisor may consider necessary. Protection by the network operator for any purpose whatsoever, does not absolve the Contractor of his responsibilities in terms of the Contract.
- 21.4 The Contractor shall take all precautions and appoint guards, watchmen and compound managers for prevention of disorder among and misconduct by the persons employed on the Works and by any other persons, whether employees or not, on the work site and for the preservation of the peace and protection of persons and property in the direct neighbourhood. Any relocation of camps because of disorder shall be at the Contractor's expense.
- 21.5 All operations necessary for the execution of the Works, including the provision of any temporary work and camping sites, shall be carried out so as not to cause veld fires, ground and environmental pollution, soil erosion or restriction of or interference with streams, furrows, drains and water supplies.
- If the original surface of the ground is disturbed in connection with the Works, it shall be made good by the Contractor to the satisfaction of the land owner, occupier or responsible authority.
- 21.6 The Contractor shall take all reasonable steps to minimise noise and disturbance when carrying out the Works, including work permitted outside normal working hours.
- 21.7 Dumping of waste or excess materials by the Contractor shall, in urban areas, be done under the direction and control of, and at sites made available by the local authority. Dumping outside local authority boundaries shall be done only with the express permission and under the direction and control of the Contract Supervisor.
- 21.8 The Contractor shall comply with environmental protection measures and specifications stipulated by the Contract Supervisor and/or local and environmental authorities.
- 22.0 INTERFERENCE WITH THE NETWORK OPERATOR'S ASSETS AND WORK ON OPEN LINES**
- 22.1 The Contractor shall not interfere in any manner whatsoever with an open line, nor shall he carry out any work or perform any act which affects the security, use or safety of an open line except with the authority of the Contract Supervisor and in the presence of a duly authorised representative of the network operator.
- 22.2 The Contractor shall not carry out any work or operate any plant, or place any material whatsoever nearer than three metres from the centre line of any open line except with the written permission of the Contract Supervisor and subject to such conditions as he may impose.
- 22.3 Care must be taken not to interfere with or damage any services such as overhead wire routes, cables or pipes and optical fibre cable, except as provided for the work specified. The Contractor will be held responsible for any damage to or interruption of such services arising from any act or omission on his part or of any of his employees, or persons engaged by him on the Works. The cost of repairing, replacing or restoring the services, as well as all other costs arising from any damage to services, shall be borne by, and will be recovered from the Contractor.
- 22.4 Authority granted by the Contract Supervisor and the presence of an authorised representative of the network operator in terms hereof, shall not relieve the Contractor of his duty to comply with this specification.
- 23.0 ACCESS, RIGHTS-OF-WAY AND CAMPSITES**
- 23.1 Where entry onto the network operator's property is restricted, permission to enter will be given only for the purpose of carrying out the Works and will be subject to the terms and conditions laid down by the network operator.
- 23.2 The Contractor shall arrange for campsites, workplaces and access thereto as well as for any right-of-

way over private property to the site of the Works, and for access within the boundaries of the network operator's property. The owners of private property to be traversed shall be approached and treated with tact and courtesy by the Contractor, who shall, if necessary, obtain a letter of introduction to such property owners from the Contract Supervisor.

The Contractor shall be responsible for the closing of all gates on roads and tracks used by him or his employees. Except with the prior approval of the Contract Supervisor and the owner or occupier of any private land to be traversed, the Contractor shall not cut, lower, damage, remove or otherwise interfere with any fence or gate which is either on the network operator's property or on private property and which restricts access to the Works. Where such approval has been given, the Contractor shall prevent entry of animals or unauthorised persons onto the network operator's or private property, and shall make the fences safe against trespass at the close of each day's work.

- 23.3 The Contractor shall take all reasonable steps to confine the movement of vehicles and plant to the approved right-of-way to minimise damage to property, crops and natural vegetation.
- 23.4 When access is no longer required, and before completion of the Works, the Contractor shall repair, restore or replace any fence or gate damaged during execution of the Works to the satisfaction of the Contract Supervisor and shall furnish the Contract Supervisor with a certificate signed by the owner and occupier of land over which he has gained access to a campsite, work, yard and the Works, certifying that the owner and occupier have no claim against the Contractor or the network operator arising from the Contractor's use of the land. Should the Contractor be unable to obtain the required certificate, he shall report the circumstances to the Contract Supervisor.

24.0 SUPERVISION

- 24.1 The Contract Supervisor will provide overall technical superintendence of the Works, and may direct the Contractor in terms of the provisions of the Contract or in respect of any measures which the Contract Supervisor may require for the operations of the network operator, the safety of trains, property and workmen of the network operator, and for the safety of other property and persons. The Contractor shall carry out the directions of the Contract Supervisor. The superintendence exercised by the Contract Supervisor, including any agreement, approval, refusal or withdrawal of any approval given, shall not relieve the Contractor of any of his duties and liabilities under the Contract, and shall not imply any assumption by the network operator or by the Contract Supervisor of the legal and other responsibilities of the Contractor in carrying out the Works.
- 24.2 The Contract Supervisor may delegate to any deputy or other person, any of his duties or functions under the Contract. On receiving notice in writing of such delegation, the Contractor shall recognise and obey the deputy or person to whom any such duties or functions have been delegated as if he were the Contract Supervisor.
- 24.3 The Contractor shall exercise supervision over the Works at all times when work is performed or shall be represented by an agent having full power and authority to act on behalf of the Contractor. Such agent shall be competent and responsible, and have adequate experience in carrying out work of a similar nature to the works, and shall exercise personal supervision on behalf of the Contractor. The Contract Supervisor shall be notified in writing of such appointment which will be subject to his approval.
- 24.4 The Contractor or his duly authorised agent shall be available on the site at all times while the Works are in progress to receive the orders and directions of the Contract Supervisor.

25.0 HOUSING OF EMPLOYEES

- 25.1 The Contractor shall, where necessary, make his own arrangements for suitable housing of his employees. Where temporary housing is permitted by the Contract Supervisor on any part of the site, the Contractor shall provide suitable sanitation, lighting and potable water supplies in terms of the requirements of the local authority or the current network operator's specification; Minimum Communal Health Requirements in Areas outside the Jurisdiction of a Local Authority - E.4B, as applicable.
- 25.2 Fouling the area inside or outside the network operator's boundaries shall be prevented. The Contractor will be called upon by the Contract Supervisor to dispose of any foul or waste matter generated by the Contractor.

26.0 OPTICAL FIBRE CABLE ROUTES

- 26.1 The Contractor shall not handle, impact, move or deviate any optical fibre cable without prior approval.
- 26.2 Works that in any way affect the optical fibre cable requires prior approval from the Contract Supervisor

who will determine the work method and procedures to be followed.

"PREVIEW COPY ONLY"

PART B - SPECIFICATION FOR WORK NEAR HIGH-VOLTAGE ELECTRICAL EQUIPMENT

27.0 GENERAL

27.1 This specification is based on the contents of Transnet's publication ELECTRICAL SAFETY INSTRUCTIONS, as amended, a copy of which will be made available on loan to the Contractor for the duration of the contract.

These instructions apply to all work near "live" high-voltage equipment maintained and/or operated by the network operator, and the onus rests on the Contractor to ensure that he obtains a copy.

27.2 This specification must be read in conjunction with and not in lieu of the Electrical Safety Instructions.

27.3 The Contractor's attention is drawn in particular to the contents of Part I, Sections 1 and 2 of the Electrical Safety Instructions.

27.4 The Electrical Safety Instructions cover the minimum safety precautions which must be taken to ensure safe working on or near high-voltage electrical equipment, and must be observed at all times. Should additional safety measures be considered necessary because of peculiar local conditions, these may be ordered by and at the discretion of the Electrical Officer (Contracts).

27.5 The Contractor shall obtain the approval of the Electrical Officer (Contracts) before any work is done which causes or could cause any portion of a person's body or the tools he is using or any equipment he is handling, to come within 3 metres of any "live" high-voltage equipment.

27.6 The Contractor shall regard all high-voltage equipment as "live" unless a work permit is in force.

27.7 Safety precautions taken or barriers erected shall comply with the requirements of the Electrical Officer (Contracts), and shall be approved by him before the work to be protected is undertaken by the Contractor. The Contractor shall unless otherwise agreed, bear the cost of the provision of the barriers and other safety precautions required, including the attendance of the network operator's staff where this is necessary.

27.8 No barrier shall be removed unless authorised by the Electrical Officer (Contracts).

28.0 WORK ON BUILDINGS OR FIXED STRUCTURES

28.1 Before any work is carried out or measurements are taken on any part of a building, fixed structure or earthworks of any kind above ground level situated within 3 metres of "live" high-voltage equipment, the Electrical Officer (Contracts) shall be consulted to ascertain the conditions under which the work may be carried out.

28.2 No barrier erected to comply with the requirements of the Electrical Officer (Contracts) shall be used as temporary staging or shuttering for any part of the Works.

28.3 The shuttering for bridge piers, abutments, retaining walls or parapets adjacent to or over any track may be permitted to serve as a barrier, provided that it extends at least 2,5 metres above any working level in the case of piers, abutments and retaining walls and 1,5 metres above any working level in the case of parapets.

29.0 WORK DONE ON OR OUTSIDE OF ROLLING STOCK, INCLUDING LOADING OR UNLOADING

29.1 No person may stand, climb or work, whilst on any platform, surface or foothold:

29.1.1 higher than the normal unrestricted access way, namely -

29.1.1.1 external walkways on diesel, steam and electric locomotives, steam heat vans, etc. and

29.1.1.2 walkways between coaches and locomotives.

29.1.2 of restricted access ways in terms of the Electrical Safety Instructions namely -

29.1.2.1 the floor level of open wagons

29.1.2.2 external walkways or decks of road-rail vehicles, on-track maintenance machines and material trains.

29.1.3 Unauthorised staff working on these platforms must be directly supervised by duly authorised persons in terms of clause 607.1.3 of the Electrical Safety Instructions. These persons must attend the relevant electrical safety module training. A letter of training must then be issued by an accredited training authority. A Category C Certificate of Authority must be obtained from the

local depot examining officer.

- 29.2 When in the above positions no person may raise his hands or any equipment he is handling above his head.
- 29.3 In cases where the Contractor operates his own rail mounted equipment, he shall arrange for the walkways on this plant to be inspected by the Electrical Officer (Contracts) and approved, before commencement of work.
- 29.4 The handling of long lengths of material such as metal pipes, reinforcing bars, etc should be avoided, but if essential they shall be handled as nearly as possible in a horizontal position below head height.
- 29.5 The Responsible Representative shall warn all persons under his control of the danger of being near "live" high-voltage equipment, and shall ensure that the warning is fully understood.
- 29.6 Where the conditions in clauses 30.1 to 30.4 cannot be observed the Electrical Officer (Contracts), shall be notified. He will arrange for suitable Safety measures to be taken. The Electrical Officer (Contracts), may in his discretion and in appropriate circumstances, arrange for a suitable employee of the Contractor to be specially trained by the network operator and at the Contractor's cost, as an Authorised Person to work closer than 3 metres from "live" overhead conductors and under such conditions as may be imposed by the senior responsible electrical engineer of the network operator.

30.0 USE OF EQUIPMENT

30.1 Measuring Tapes and Devices

- 30.1.1 Measuring tapes may be used near "live" high-voltage equipment provided that no part of any tape or a person's body comes within 3 metres of the "live" equipment.
- 30.1.2 In windy conditions the distance shall be increased to ensure that if the tape should fall it will not be blown nearer than 3 metres from the "live" high-voltage equipment.
- 30.1.3 Special measuring devices longer than 2 metres such as survey sticks and rods may be used if these are of non-conducting material and approved by the responsible Electrical Engineer of the network operator, but these devices must not be used within 3 metres of "live" high-voltage equipment in rainy or wet conditions.
- 30.1.4 The assistance of the Electrical Officer (Contracts) shall be requested when measurements within the limits defined in clauses 31.1.1 to 31.1.3 are required.
- 30.1.5 The restrictions described in 31.1.1 to 31.1.3 do not apply on a bridge deck between permanent parapets nor in other situations where a barrier effectively prevents contact with the "live" high-voltage equipment.

30.2 Portable Ladders

- 30.2.1 Any type of portable ladder longer than 2 metres may only be used near "live" high-voltage equipment under the direct supervision of the Responsible Representative. He shall ensure that the ladder is always used in such a manner that the distance from the base of the ladder to any "live" high-voltage equipment is greater than the fully extended length of the ladder plus 3 metres. Where these conditions cannot be observed, the Electrical Officer (Contracts) shall be advised, and he will arrange for suitable safety measures to be taken.

31.0 CARRYING AND HANDLING MATERIAL AND EQUIPMENT

- 31.1 Pipes, scaffolding, iron sheets, reinforcing bars and other material which exceeds 2 metres in length shall be carried completely below head height near "live" high-voltage equipment. For maximum safety such material should be carried by two or more persons so as to maintain it as nearly as possible in a horizontal position. The utmost care must be taken to ensure that no part of the material comes within 3 metres of any "live" high-voltage equipment.
- 31.2 Long lengths of wire or cable shall never be run out in conditions where a part of a wire or cable can come within 3 metres of any "live" high-voltage equipment unless the Electrical Officer (Contracts) has been advised and has approved appropriate safety precautions.
- 31.3 The presence of overhead power lines shall always be taken account of especially when communications lines or cables or aerial cables, stay wires, etc. are being erected above ground level.

32.0 PRECAUTIONS TO BE TAKEN WHEN ERECTING OR REMOVING POLES, ANTENNAE, TREES ETC.

- 32.1 A pole may be handled for the purpose of erection or removal near high-voltage equipment under the following conditions:

(i) If the distance between the point at which the pole is to be erected or removed and the nearest "live" high-voltage equipment is more than the length of the pole plus 3 metres, the work shall be supervised by the Responsible Representative.

(ii) If the distance described in (i) is less than the length of the pole plus 3 metres, the Electrical Officer (Contracts) shall be consulted to arrange for an Authorised Person to supervise the work and to ensure that the pole is earthed where possible. The pole shall be kept in contact with the point of erection, and adequate precautions shall be taken to prevent contact with "live" high-voltage equipment.

32.2 The cost of supervision by an Authorised Person and the provision of earthing shall, unless otherwise agreed, be borne by the Contractor.

32.3 The provisions of clauses 33.1 and 33.2 shall also apply to the erection or removal of columns, antennae, trees, posts, etc.

33.0 USE OF WATER

33.1 No water shall be used in the form of a jet if it can make contact with any "live" high-voltage equipment or with any person working on such equipment.

34.0 USE OF CONSTRUCTION PLANT

34.1 "Construction plant" entails all types of plant including cranes, piling frames, boring machines, excavators, draglines, dewatering equipment and road vehicles with or without lifting equipment.

34.2 When work is being undertaken in such a position that it is possible for construction plant or its load to come within 3 metres of "live" high-voltage equipment, the Electrical Officer (Contracts) shall be consulted. He will arrange for an Authorised Person to supervise the work and to ensure that the plant is adequately earthed. The Electrical Officer (Contracts) will decide whether further safety measures are necessary.

34.3 The cost of any supervision by an Authorised Person and the provision of earthing shall, unless otherwise agreed, be borne by the Contractor.

34.4 When loads are handled by cranes, non-metallic rope hand lines shall be used, affixed to such loads so as to prevent their swinging and coming within 3 metres of "live" high-voltage equipment.

34.5 Clauses 35.1 to 35.4 shall apply *mutatis mutandis* to the use of maintenance machines of any nature.

35.0 WORK PERFORMED UNDER DEAD CONDITIONS UNDER COVER OF A WORK PERMIT

35.1 If the Responsible Representative finds that the work cannot be done in safety with the high-voltage electrical equipment "live", he shall consult the Electrical Officer (Contracts) who will decide on the action to be taken.

35.2 If a work permit is issued the Responsible Representative shall-

(i) before commencement of work ensure that the limits within which work may be carried out have been explained to him by the Authorised Person who issued the permit to him, and that he fully understands these limits.

(ii) sign portion C of the permit before commencement of work;

(iii) explain to all persons under his control the limits within which work may be carried out, and ensure that they fully understand these limits;

(iv) care for the safety of all persons under his control whilst work is in progress; and

(v) withdraw all personnel under his control from the equipment on completion of the work before he signs portion D of the work permit.

36.0 TRACTION RETURN CIRCUITS IN RAILS

36.1 DANGEROUS CONDITIONS CAN BE CREATED BY REMOVING OR SEVERING ANY BOND.

36.2 Broken rails with an air gap between the ends, and joints at which fishplates are removed under "broken bond" conditions, are potentially lethal. The rails on either side of an air gap between rail ends on electrified lines shall not be touched simultaneously until rendered safe by the network operator personnel.

36.3 The Contractor shall not break any permanent bonds between rails or between rails and any structure. He shall give the Contract Supervisor at least 7 days written notice when removal of such bonds is necessary.

36.4 No work on the track which involves interference with the traction return rail circuit either by cutting or removing the rails, or by removal of bonds shall be done unless the Electrical Officer (Contracts) is consulted. He will take such precautions as may be necessary to ensure continuity of the return circuit before permitting the work to be commenced.

37.0 HIGH-VOLTAGE ELECTRICAL EQUIPMENT NOT MAINTAINED AND/OR OPERATED BY THE NETWORK OPERATOR

Where the work is undertaken on or near high-voltage electrical equipment which is not maintained and/or operated by the network operator, the Occupational Health and Safety Act No. 85 of 1993, and Regulations and Instructions, or the Mines Health and Safety Act (Act 29 of 1996), shall apply.

Such equipment includes:-

- (i) Eskom and municipal equipment;
- (ii) The Contractor's own power supplies; and
- (iii) Electrical equipment being installed but not yet taken over from the Contractor.

END

"PREVIEW COPY ONLY"

HORIZONTAL CLEARANCES :
1 065mm TRACK GAUGE

ANNEXURE 1
SHEET 1 of 5



RADIUS (m)	WITH CANT		NO CANT		WITH CANT	
	H (mm)	L (mm)	H & L	C (mm)	B (mm)	C (mm)
90	2 730	3 090	2 780	2 100	1 230	2 100
100	2 700	3 030	2 750	2 050	1 140	2 050
120	2 650	2 970	2 700	2 000	1 160	2 000
140	2 620	2 920	2 660	1 950	1 175	1 950
170	2 590	2 870	2 630	1 970	1 190	1 970
200	2 570	2 820	2 600	1 950	1 205	1 950
250	2 550	2 790	2 580	1 920	1 230	1 920
300	2 540	2 760	2 560	1 900	1 250	1 900
350	2 530	2 730	2 540	1 890	1 270	1 890
400	2 520	2 710	2 530	1 875	1 290	1 875
500	2 510	2 680	2 520	1 850	1 320	1 850
600	2 500	2 660	2 510	1 830	1 340	1 830
800	2 490	2 620	2 500	1 790	1 365	1 790
1 000	2 480	2 600	2 490	1 760	1 380	1 760
1 200	2 480	2 580	2 490	1 730	1 200	1 730
1 500	2 480	2 550	2 480	1 700	1 415	1 700
2 000	2 480	2 500	2 480	1 660	1 440	1 660
3 000	2 470	2 470	2 470	1 600	1 500	1 600
>5 000	2 460	2 460	2 460	1 600	1 600	1 600

REMARKS:

- H AND B IS THE REQUIRED HORIZONTAL CLEARANCE ON THE HIGH LEG OF THE CURVE BASED ON MINIMUM CANT.
- L AND C IS THE REQUIRED HORIZONTAL CLEARANCE ON THE LOW LEG OF THE CURVE BASED ON MAXIMUM CANT.
- INTERMEDIATE VALUES MAY BE INTERPOLATED BY THE ENGINEER IN CHARGE.
- FOR WORKSHOP AREAS AND TEMPORARY WORK, CLEARANCES H AND L MAY BE REDUCED BY 300mm.
- SEE ANNEXURE 1 SHEET 3 FOR PLATFORM CLEARANCES.
- ALSO REFER TO REMARKS 4 TO 8 OF ANNEXURE 1 SHEET 2.
- USE SMALLER RADIUS IF RADIUS IN BETWEEN

VERTICAL CLEARANCES :
1 065mm TRACK GAUGE

ANNEXURE 1
SHEET 2 of 5

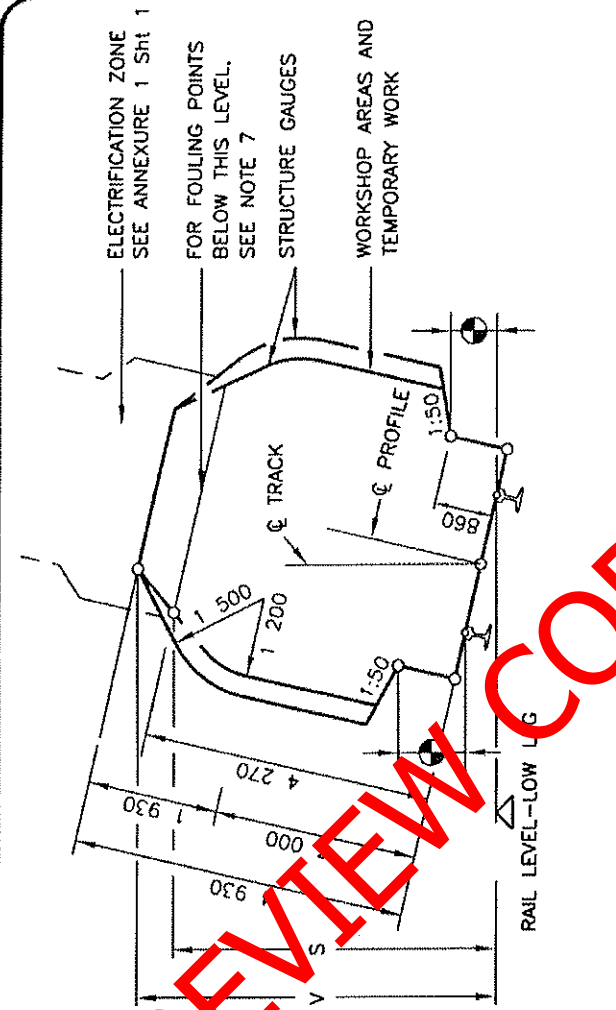

LOCATION	ELECTRIFIED (PRESENT OR FUTURE)		
	3kV & 25kV	30kV	
ALL AREAS OTHER THAN THOSE INDICATED BY * BELOW	RADIUS (mm)	V (mm)	S (mm)
	100	5 050	4 470
	300	5 020	4 410
	600	5 000	4 370
	1 000	4 990	4 350
	1 500	4 960	4 310
	2 000	4 940	4 290
>3 000	4 930	4 270	
* OVER OR NEAR POINTS AND CROSSING IF REQUIRED BY ELECTRICAL IRRESPECTIVE OF RADIUS	5 650	6 000	

REMARKS:

1. V IS THE REQUIRED VERTICAL CLEARANCE EXCEPT WHERE REDUCED CLEARANCE S APPLIES.
2. S IS THE MINIMUM VERTICAL CLEARANCE FOR STRUCTURES AND TEMPORARY WORK OVER NON-ELECTRIFIED LINES.
3. INTERMEDIATE VALUES MAY BE INTERPOLATED BY THE ENGINEER IN CHARGE.
4. FOR APPLICATION AT CURVES
 - 4.1 APPLY INCREASED CLEARANCES FOR CURVES TO POINTS 3m BEYOND THE ENDS OF THE CIRCULAR CURVE.
 - 4.2 REDUCE CLEARANCES AT A UNIFORM RATE OVER THE REMAINDER OF THE TRANSITION CURVE.
 - 4.3 FOR NON-TRANSITIONED CURVES REDUCE AT A UNIFORM RATE OVER A LENGTH OF 15m ALONG STRAIGHTS.
5. NEW STRUCTURES: SEE BRIDGE CODE.
6. TUNNELS: SEE DRAWING BE 82-35.
7. FOULING POINTS: SEE CLAUSE 8.1.
8. CLEARANCES ARE BASED ON 15m BOGIE CENTRES AND 21.2m VEHICLE BODY LENGTH.
9. SEE ANNEXURE 1 SHEET 3 FOR PLATFORM CLEARANCES.

CLEARANCES : PLATFORMS

ANNEXURE 1
SHEET 3 of 5

PLATFORMS : TRACK GAUGE 1 065mm

PASSENGERS

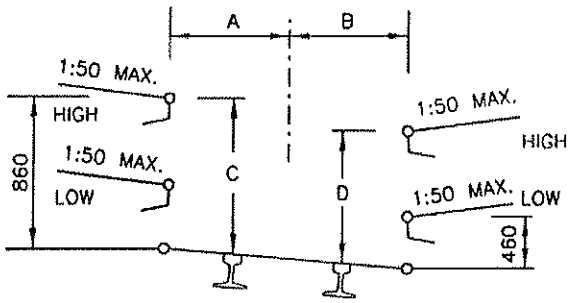

GOODS

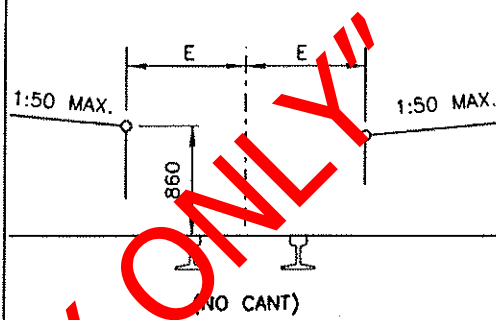

RADIUS (m)	A (mm)	B (mm)	C (mm)	D (mm)	E (mm)
90	1 690	1 820	890	810	1 840
100	1 650	1 790	890	810	1 810
120	1 610	1 740	890	810	1 760
140	1 580	1 700	890	810	1 720
170	1 550	1 660	890	810	1 690
200	1 530	1 630	890	820	1 670
250	1 520	1 600	890	820	1 640
300	1 520	1 580	890	830	1 620
350	1 520	1 560	880	830	1 600
400	1 520	1 550	880	840	1 590
500	1 520	1 540	880	850	1 580
600	1 520	1 530	870	850	1 570
800	1 520	1 520	860	860	1 560
1 200	1 520	1 520	860	860	1 550
2 000	1 520	1 520	860	860	1 540
3 000	1 520	1 520	860	860	1 530
STRAIGHT	1 520	1 520	860	860	1 520

REMARKS:

1. NO CANT TO BE APPLIED EXCEPT WHEN THE GOODS PLATFORM IS ON A RUNNING LINE.
2. INTERMEDIATE VALUES MAY BE INTERPOLATED BY THE ENGINEER IN CHARGE.
3. 8m TO MAIN STATION-BUILDINGS AND 3m TO ALL OTHER STRUCTURES.
4. TOLERANCES : SEE CLAUSE 8.0.10.
5. ALWAYS USE THE SMALLEST RADIUS

STRUCTURES ON PLATFORMS : 1 065mm AND 610mm TRACK GAUGE

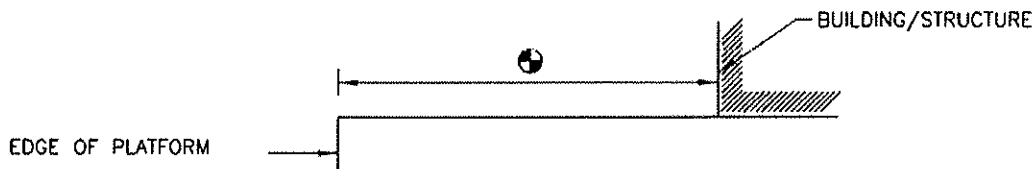

CLEARANCES : 610mm TRACK GAUGE

ANNEXURE 1
SHEET 5 of 5

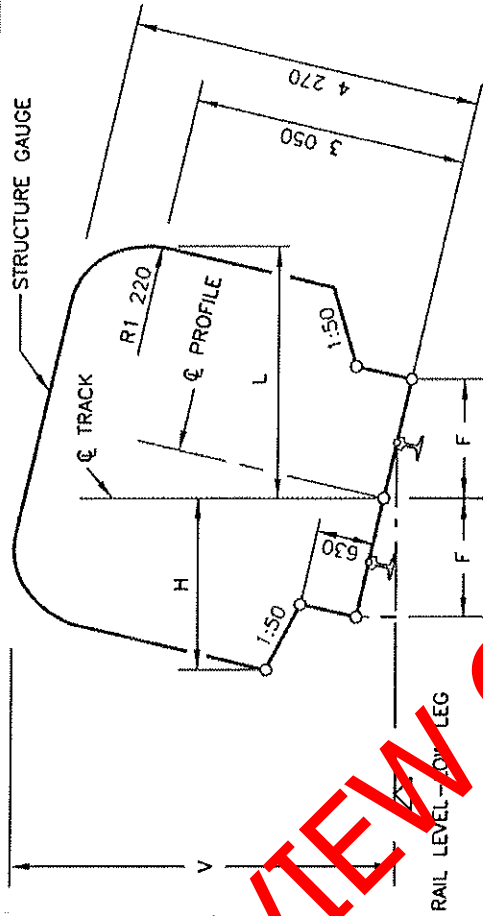

RADIUS (m)	F (mm)
50	1 550
60	1 510
80	1 460
100	1 430
120	1 410
140	1 390
170	1 380
200	1 370
250	1 360
300	1 350
600	1 330
1 000	1 320
>2 000	1 320
STRAIGHT	1 310

RADIUS (m)	WITH CANT		NO CANT H & L (mm)	V (mm)
	H (mm)	L (mm)		
50	2 370	2 490	2 400	300
70	2 310	2 420	2 330	310
100	2 260	2 370	2 280	310
140	2 220	2 340	2 250	310
200	2 200	2 300	2 220	300
300	2 190	2 270	2 200	300
500	2 180	2 230	2 190	290
700	2 170	2 200	2 180	270
1 000	2 170	2 170	2 170	270
>2 000	2 160	2 160	2 160	270

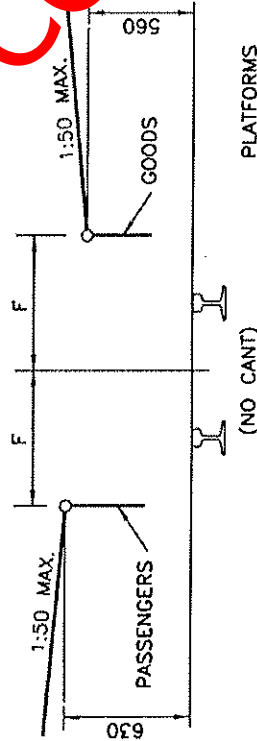

REMARKS:

- H IS THE MINIMUM HORIZONTAL CLEARANCE ON THE OUTSIDE OF THE CURVE BASED ON MINIMUM CANT.
- L IS THE MINIMUM HORIZONTAL CLEARANCE ON THE INSIDE OF THE CURVE BASED ON MAXIMUM CANT.
- V IS THE MINIMUM VERTICAL CLEARANCE.
- FOR APPLICATION AT CURVES:
 - APPLY INCREASED CLEARANCES FOR CURVES TO POINTS 2m BEYOND THE ENDS OF THE CIRCULAR CURVE.
 - REDUCE CLEARANCES AT A UNIFORM RATE OVER THE REMAINDER OF THE TRANSITION CURVE.
 - FOR NON-TRANSITIONED CURVES REDUCE AT A UNIFORM RATE OVER A LENGTH OF 18m ALONG STRAIGHTS.
- INTERMEDIATE VALUES MAY BE INTERPOLATED BY THE ENGINEER IN CHARGE.
- ALSO REFER TO REMARKS 5, 6 AND 7 OF ANNEXURE 1 SHEET 2.
- CLEARANCES ARE BASED ON 9 700mm BOGIE CENTRES AND 13 700mm VEHICLE BODY LENGTH.
- SEE ANNEXURE 1 SHEET 3 FOR STRUCTURES ON PLATFORMS.