



Transnet SOC Limited
Transnet RME

REQUEST FOR QUOTATION

BOARD LIST TFR RME
 TRANSNET FREIGHT RAIL - RME
 PROCUREMENT DEPARTMENT
 2000

Registration Number: 1990/000900/06
Vat Number : 4720103177

Attention:

TFR Official Tender Board.
 Telephone Number :
 Fax Number :
 Vendor Number :2004815

Quotation Deadline Date : 24.10.2014
Quotation Deadline Time : 12:00

REQUEST for QUOTATION

Transnet RME
RFQ Number / Date
 6000210121 / 16.10.2014
Contact Person / Telephone
 Eddie Quinn / 035 905 3664
Return to FAX Number/EMAIL
 086 1159978 / TCPtendersRichardsBay@Transnet.net

Item	Material	Description	RFQ Qty	Unit	Required Del date	Confirm Del date	Unit Price Excl	Total Price Excl
00010		Attachment Fitting asse	65	ea	28.11.2014			

Supply & Deliver, 65 x Attachment Fitting Assembly Steady Arm on Cross Spans, Complete as per the attached Drawing No: CEE-TNB-3 (Sheet 1 & 2.), and supporting drawings CEE-TX-66 & 81.
 Delivered to: 1 Morris Road - Empangeni Rail - OHLE Store.
 Contact: Mr Pierre Crocker Tel: 035-905 3633 / 035 279 0437.

Transnet Limited t/a Transnet Freight Rail (P.M.E.) # Richards Bay, hereby invite your company to submit a detailed quotation for:

The Supply & Delivery of 65 x Attachment Fitting Assembly Steady Arm on Cross Spans, Complete as per the attached Drawing No: CEE-TNB-3 (Sheet 1 & 2.), and supporting drawings CEE-TX-66 & 81, as requested above.

All technical queries relating to this invitation may be addressed to;
 Mr. Pierre Crocker Tel: 083 279 0734 / 035-905 3638.

All tender related queries pertaining to this invitation may be addressed to;
 Mr. Eddie Quinn, Tel: 035 # 905 3664.





Transnet SOC Limited
Transnet RME
 BOARD LIST TFR RME
 TRANSNET FREIGHT RAIL - RME
 PROCUREMENT DEPARTMENT
 2000
 YOUR VAT NUMBER WITH US: NOT

REQUEST FOR QUOTATION

Registration Number: 1990/000900/06
Vat Number : 4720103177

Attention:
 TFR Official Tender Board.
 Telephone Number :
 Fax Number :
 Vendor Number :2004815

Quotation Deadline Date : 24.10.2014
Quotation Deadline Time : 12:00

REQUEST for QUOTATION
 Transnet RME
RFQ Number / Date
 6000210121 / 16.10.2014
Contact Person / Telephone
 Eddie Quinn / 086 515 905 3664
Return to FAX Number/EMAIL
 086 5159978 / TCPTendersRichardsBay@Transnet.net

Item	Material	Description	RFQ Qty	UoM	Required Del date	Confirm Del date	Unit Price Excl	Total Price Excl
------	----------	-------------	---------	-----	-------------------	------------------	-----------------	------------------

The closing time for receipt of your official quotations is 12:00 hours on Friday 24 October 2014.

Transnet desires a validity period of 90 (Ninety) days from the closing date of this RFQ.

Telephonic and late quotes will not be accepted.
 All quotations should be clearly marked, and may be forwarded to:
 Me Yogeshnie Gengan, Tender & Fax Assistant,
 Fax No: 086 515 9978 and / or
 e-mailed to: TCPTendersRichardsBay@transnet.net

The contractor's address and identification details have to be shown on each quotation submitted.

Please submit the following documents with your quotation;

- Valid Tax Clearance certificate
- Copy of your latest B.B.B.F.E Certificate.

Failing to submit any of the documents mentioned above, could result in your quotation to be disqualified / not accepted.

Note: #Transnet may not necessarily accept the lowest or any other offer and reserves the right to select in its favor any or, a portion of any offer made"

If you have been contacted directly by the Supply Chain Office (Via a RFQ.), and you are unable to quote for these items, please submit a NO QUOTE.

Otherwise we look forward to receive your detailed quote by the date and time stated.

N.B.

PREVIEW COPY



Transnet SOC Limited
Transnet RME
 BOARD LIST TFR RME
 TRANSNET FREIGHT RAIL - RME
 PROCUREMENT DEPARTMENT
 2000
 YOUR VAT NUMBER WITH US: NOT

REQUEST FOR QUOTATION

Registration Number: 1990/000900/06
Vat Number : 4720103177

Attention:
 TFR Official Tender Board.
 Telephone Number :
 Fax Number :
 Vendor Number :2004815

Quotation Deadline Date : 24.10.2014
Quotation Deadline Time : 12:00

REQUEST for QUOTATION
 Transnet RME
RFQ Number / Date
 6000210121 / 16.10.2014
Contact Person / Telephone
 Eddie Quinn / 025 905 3664
Return to FAX Number/EMAIL
 0863 159978 / TCPtendersRichardsBay@Transnet.net

Item	Material	Description	RFQ Qty	UoM	Required Del date	Confirm Del date	Unit Price Excl	Total Price Excl
------	----------	-------------	---------	-----	-------------------	------------------	-----------------	------------------

Yours faithfully,

Delivery Address

TFR RME Richards Bay
 Old Naval Base, Commodores Clo
 Meerensee, Richards Bay
 3900

This RFQ is subject to the following conditions:

1. Price/s : The price/s quoted in SA currency and is excluding of V.A.T
2. Delivery : The price/s quoted should include delivery cost to the delivery address stated on the RFQ
3. Returnables : A valid tax clearance certificate and BBBEE certificate from a SANAS accredited verification agency attached to quotation for all quotes above R30 000.
 Please note that only the original Transnet RFQ will be accepted and all other correspondence to be attached to the original
4. Safety : To confirm to Transnet Capital Projects Health & Safety plan and specification; HAS-std-0001, copy available on request.
5. Confirmation: To confirm your participation in this tender process please sign and return this document as immediate effect prior to the quotation deadline.
6. Negotiations: The Employer may elect to negotiate the final terms of the contract/order with the preferred tenderer in accordance with Clauses F.2.17 and F.3.13 of the CIDB Standard Conditions of Tender. A copy of which is available upon request.

Signature _____

Date _____

ITEM	DESCRIPTION / BESKRYWING	QTY HVLD	STORES ITEM MAGASYN ITEM NO	DRG TEK NO CEE	AMENDMENTS WYSIGINGS	
					NO	NAME DATE
1	STEADY ARM BRACKET SLINGERSARMSTEUN	1		TNB-3 SH VEL 2	NO	
2	U BOLT M10 U BOUT M10	2	54/3961	TX-81	1	F. HEYL 88/01/15
3	CLEVIS PIN Ø16 VURKPEN Ø16	1	54/4020	TX-66		

REDRAWN/OORGETEKEN
DRG/TEK NO WAS
CEE-54/110924
DO REF TB7/104
TK-VERW

2 *[Signature]* 91-06-11

STORES ITEM NO
ADDED
MAGASYN ITEM NO
BYGEVOEG
DO REF T90/040
TK-VERW

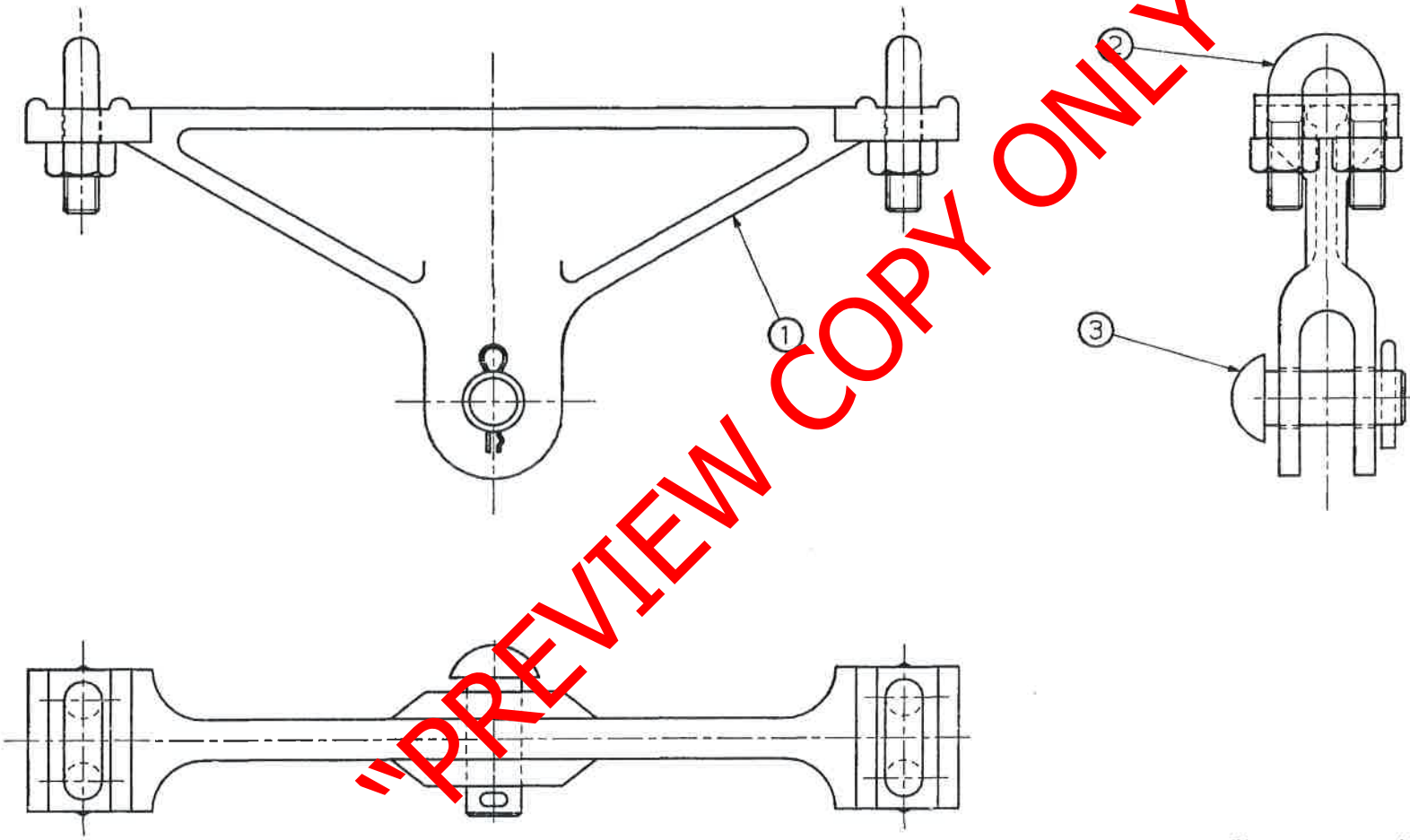

"PREVIEW COPY ONLY"

CLASS/ASSY DRG
KLAS/SAMEST-TEK

ELECTRIFICATION
TYPES REF DRG NO
CEE-MA-26 SHT 7 B
ELEKTRIFIKASIE
TIPES VERW TEK NO
CEE-MA-369 VEL 7 B

DIMENSIONS, MILLIMETRES
AFMETINGS, MILLIMETER



DO REF TK-VERW C28/71	GEN TOLERANCES, LIN± 1 ALG TOLERANSIES, ANG/HOEK±0°30'	DATE 71-03-25
DRN GET G.V.G.	ENG IR	

ELECTRIFICATION TYPE GENERAL / ELEKTRIFIKASIE TIPE ALGEMEEN
ATTACHMENT FITTING ASSEMBLY
STEADY ARMS ON CROSS SPANS

STORES ITEM NO
MAGASYN ITEM NO
54/2134

_____ F. PIENAAR _____ for
CHIEF ENGINEER HOOFINGENIEUR
(POWER SUPPLIES) (KRAGVOORSIENING)
INFRASTRUCTURE INFRASTRUKTUUR

 SPOORNET

HEGTOEBEHORESAMESTEL
RYDRAADANKERS OP DWARSSPANNE

DRAWING no CEE-
TEKENING TNB-3
SHEET 1 OF 2
VEL VAN 2

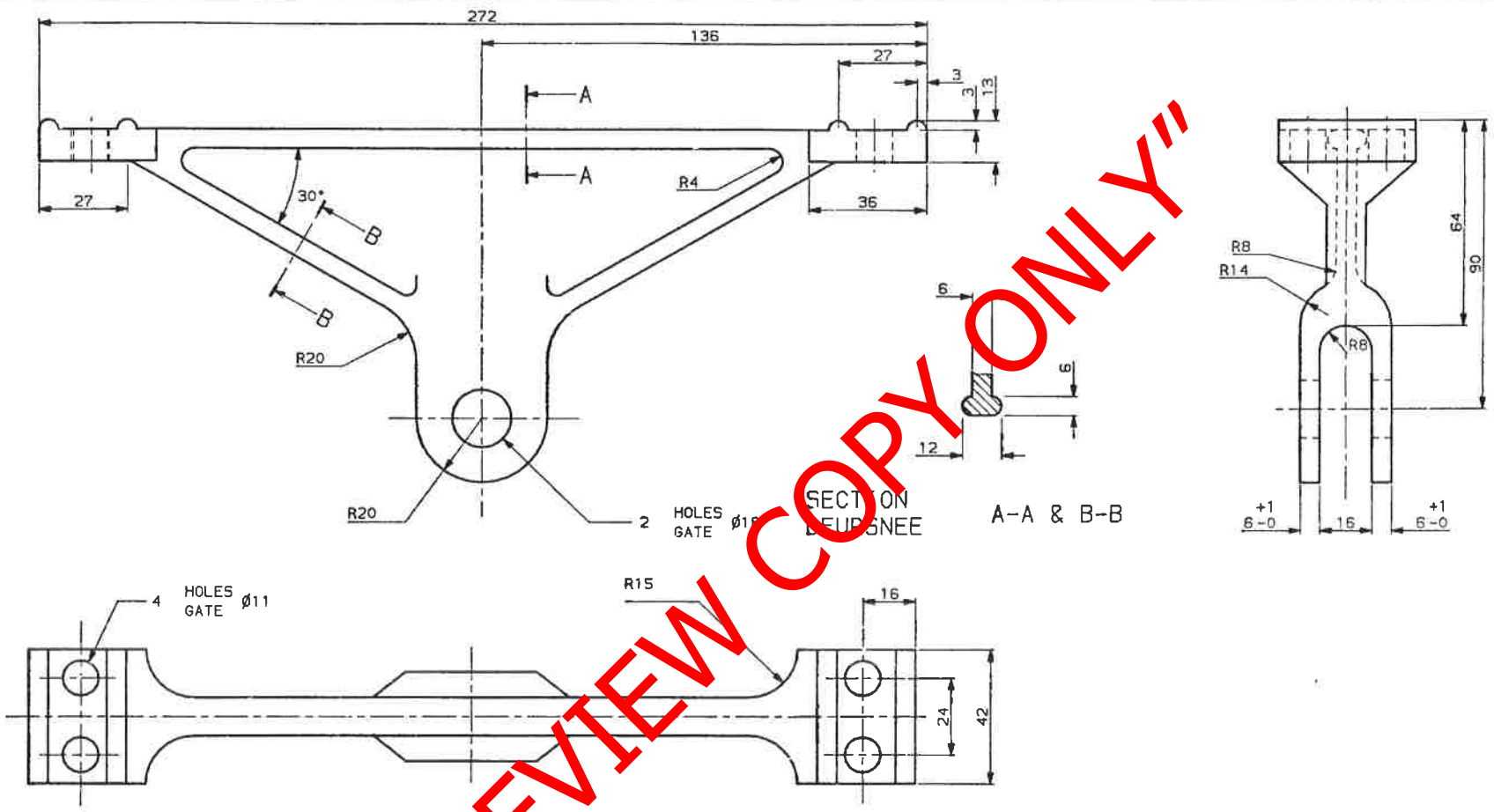

NOTES / OPMERKING

- 1 UNSPECIFIED RADII TO BE STRALE SONDER AFMETINGS R4
- 2 THE FOLLOWING PERMANENT MARKINGS MUST APPEAR ON THIS ARTICLE:
 a) SPOORNET b) MAKER'S IDENTIFICATION c) BATCH NUMBER
 DIE VOLGENDE PERMANENTE MERKE MOET OP DYE ARTIKEL VERSKYN:
 a) SPOORNET b) VERVAARDIGER SE KENTEKEN c) LOTNOMMER
- 3 FINISH, ZINC COAT TO SPEC AFWERKING, SINKBEDEK VOLG SPES SABS 763

MATERIAL/MATERIAAL
 SPHEROIDAL GRAPHITE IRON
 SFEROÏDAALGRAFIEET-YSTER
 TO SPEC SABS 936 GRADE 56 50
 VOLG SPES GRAAD

DO REF TK-VERW C28/71	GEN TOLERANCES, LIN±0.5 ALG TOLERANSIES, ANG/HOEK± 0° 30'	ELECTRIFICATION TYPE, GENERAL ATTACHMENT FITTING STEADY ARMS ON CROSS SPANS
DRN GET G.V.G.	ENG IR	ELEKTRIFIKASIE TIPE, ALGEMEEN HEGTOEBEHORE RYDRAADANKERS OP DWARSSPANNE
DATE DATUM 71-03-25		
_____ E. PIENBAAR _____ for n. CHIEF ENGINEER HOOFINGENIEUR (POWER SUPPLIES) (KRAGVOORSTENING) INFRASTRUCTURE INFRASTRUKTUUR		

AMENDMENTS WYSIGINGS		
NO	NAME NAAM	DATE DATUM
1	F. HEYL	88/01/15
2		91-06-11

REDRAWN/OORGETEKEN
 DRG/TEK NO WAS
 CEE-TN-413
 DO REF T87/104
 TK-VERW

MATERIAL & NOTE 2
 REVISED
 MATERIAAL & OPM 2
 HERSIEN
 DO REF T90/040
 TK-VERW

ELECTRIFICATION TYPES
 REFERENCE DRG NO
 CEE-MA-26 SH 78
 ELEKTRIFIKASIE TIPE
 VERWYSINGSTEK-NO
 CEE-MA-369 VEL 78

STORES ITEM
 MAGASYNITEM- NO

DRAWING NO CEE-
 TEKENING TNB-3

SHEET 2 OF 2
 VEL VAN 2

PREVIEW COPY ONLY

ITEM	DESCRIPTION	QTY	STORES ITEM NO	DRG NO CEE--	AMENDMENTS
1	RIVET, STEEL, SNAP HEAD, $\phi 16$ x 60 LG	1	01/22722	---	NO NAME DATE
2	LOCKING SPLIT PIN	1	54/3734	TX-54	3 J v DÿK 94/8/4

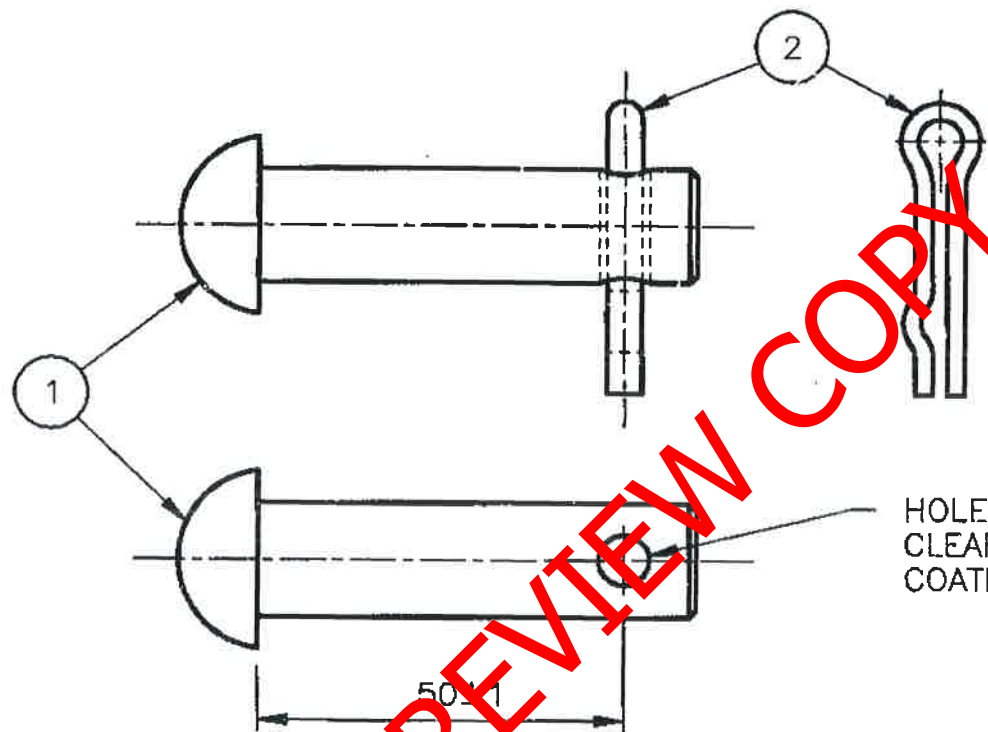

FINISH
ZINC COAT ITEM 1 TO
SPEC SABS 763 FOR
CONDITIONS IN SITU.

HOLE $\phi 7$ DRILL
CLEAR AFTER ZINC
COATING TO $\phi 6,5$

DIMENSION 50 WAS
46. TOL REVISED.
ITEM 1 STORES ITEM
NO WAS 01/22710.
DO REF T94/046

STORES ITEM NO.
54/4020

DIMENSIONS: mm
SCALE: 1:1



DRG NO CEE--
TX-66

SHT -- OF --

DO REF: C84/70	GEN TOL: LIN $\pm 0,5$	ANG \pm ---
DRN: G.J. v G.	CKD: I.T.	DATE: 70-09-09
ENG: ---	T.C. BROOK	for CHIEF ENG

INFRASTRUCTURE
(ELECTRICAL)



PIN, STRAIGHT, HEADED, $\phi 16$
WITH LOCKING SPLIT PIN

T0000639

FINISH / AFWERKING
 ZINC COAT TO
 SINKBEDEK VOLGENS SABS 763

DIMENSIONS, MILLIMETRES
 AFMETINGS, MILLIMETER

MATERIAL / MATERIAAL
 STEEL, ROUND $\phi 10 \times 108L$
 STAAL, ROND $\phi 10 \times 108L$
 STORES ITEM 11/2739
 MAGASYNITEM-
 SPEC CME 9 SYM/SIM 7
 SPES

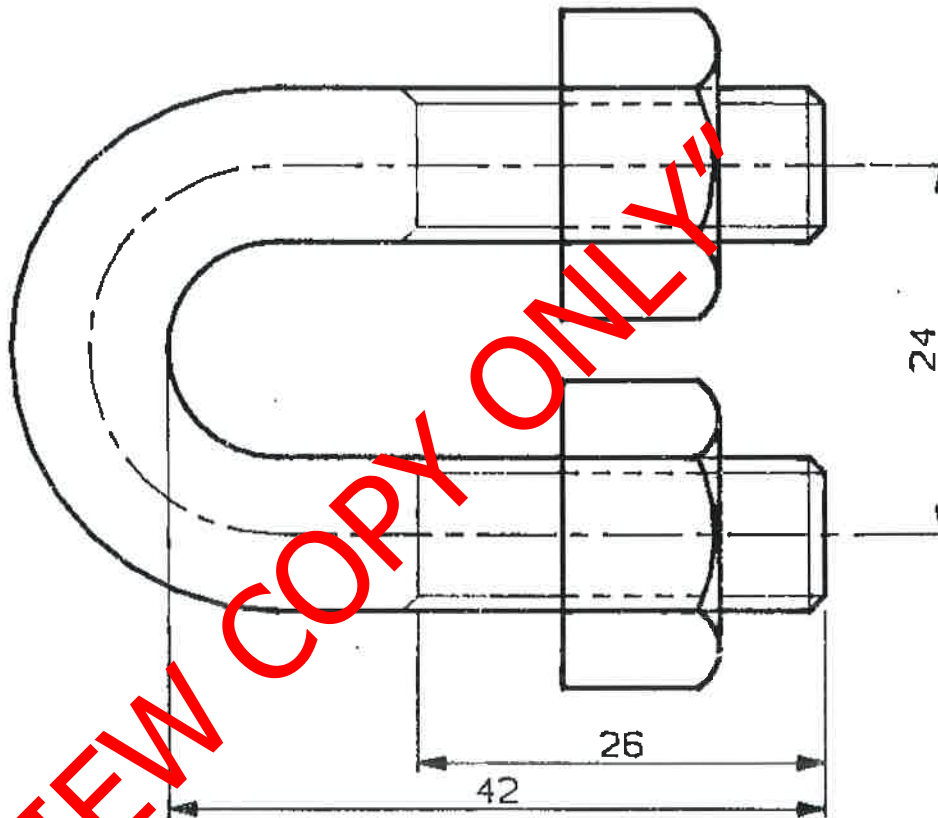

AMENDMENTS
 WYSIGINGS

NO	NAME NAAM	DATE DATUM
1	F. HEYL	88/1/15

REDRAWN
 OORGETEKEN
 DRG/TEK NO WAS
 CEE-54/110715
 DO REF T87/105
 TK-VERW

CEE-TNB-1 SH/VEL 1
 CLASS/ASSY DRG
 KLAS/SAMEST-TEK

STORES ITEM NO
 MAGASYNITEM
 54/3961

DRG NO CEE-
 TEK TX-81

SHEET 1 OF 1
 VEL VAN 1

DRN GET G.M	GEN TOL; LINES ALG TOL; LANS/HOEK±	ENG IR
TRCD NGT CAD/CRM	DO REF C29/71 TK-VERW	ENG IR
CKD NGS F.W.C	DATE 71/3/25 DATUM	F. PIENAAR for n.
CHIEF ELECTRICAL ENGINEER ELEKTRIESE HOOFINGENIEUR JOHANNESBURG		

SOUTH AFRICAN TRANSPORT SERVICES
 SUID-AFRIKAANSE VERVOERDIENSTE

ELECTRIFICATION TYPE; GENERAL
 U-BOLT, M10:
 COMPLETE WITH NUTS
 ELEKTRIFIKASIE TIPE; ALGEMEEN
 U-BOUT, M10:
 VOLLEDIG MET MOERE

PREVIEW COPY ONLY