

Transnet SOC Limited
Transnet RME

REQUEST FOR QUOTATION

BOARD LIST TFR RME
TRANSNET FREIGHT RAIL - RME
PROCUREMENT DEPARTMENT
2000

Registration Number: 1990/000900/06
Vat Number : 4720103177

Attention:

TFR Official Tender Board.
Telephone Number :
Fax Number :
Vendor Number :2004815

Quotation Deadline Date : 24.10.2014
Quotation Deadline Time : 12:00

REQUEST for QUOTATION

Transnet RME

RFQ Number / Date

6000210084 / 16.10.2014

Contact Person / Telephone

Eddie Quinn / 035 905 3664

Return to FAX Number/EMAIL

086 11599 08 / TCPtendersRichardsBay@Transnet.net

Item	Material	Description	RFQ Qty	Unit	Required Del date	Confirm Del date	Unit Price Excl	Total Price Excl
00010		M13 Wire Rope Clamp Dro	150	ea	30.10.2014			
Supply & Deliver, 150 x M13 Wire Rope Clamps, Drop Forged, HDG. Delivered to: 1 Morris Road - Empangeni Rail - OHTL Store. Contact: Mr Pierre Crocker Tel: 035-905 3638 / 083 279 0437.								
00020		M20 Turnbuckle 130mm Take-Up	20	ea	30.10.2014			
Supply & Deliver, 20 x M20 Turnbuckles 130mm Take-Up, as per the attached Drawing No: CEE-TNB-79. Delivered to: 1 Morris Road - Empangeni Rail - OHTL Store. Contact: Mr Pierre Crocker Tel: 035-905 3638 / 083 279 0437.								
00030		Rope Thimble as per Drg	70	ea	30.10.2014			

Supply & Deliver, 70 x Rope Thimbles, as per the attached Drawing No: CEE-TNB-39.



Transnet SOC Limited
Transnet RME
 BOARD LIST TFR RME
 TRANSNET FREIGHT RAIL - RME
 PROCUREMENT DEPARTMENT
 2000
 YOUR VAT NUMBER WITH US: NOT

REQUEST FOR QUOTATION

Registration Number: 1990/000900/06
Vat Number : 4720103177

Attention:
 TFR Official Tender Board.
 Telephone Number :
 Fax Number :
 Vendor Number :2004815

Quotation Deadline Date : 24.10.2014
Quotation Deadline Time : 12:00

REQUEST for QUOTATION
 Transnet RME
RFQ Number / Date
 6000210084 / 16.10.2014
Contact Person / Telephone
 Eddie Quinn / 035 905 3664
Return to V / X Number/EMAIL
 0866 159978 / TCPtendersRichardsBay@Transnet.net

Item	Material	Description	RFQ Qty	UoM	Required Del date	Confirm Del date	Unit Price Excl	Total Price Excl
------	----------	-------------	---------	-----	-------------------	------------------	-----------------	------------------

Delivered to: 1 Morris Road - Empangeni Rail - OHTE Store.
 Contact: Mr Pierre Crocker Tel: 035-905 3638 / 083 279 0437.

00040		Rope Thimble as per Drg	170	ea	30.10.2014			
-------	--	-------------------------	-----	----	------------	--	--	--

Supply & Deliver, 170 x Rope Thimbles, as per the attached Drawing No: CEE-TNB-85.
 Delivered to: 1 Morris Road - Empangeni Rail - OHTE Store.
 Contact: Mr Pierre Crocker Tel: 035-905 3638 / 083 279 0437.

Transnet Limited t/a Transnet Freight Rail (R.M.E.) # Richards Bay, hereby invite your company to submit a detailed quotation for:

The Supply & Delivery of various Lifting Items, as requested above.

All technical queries relating to this invitation may be addressed to;
 Mr. Pierre Crocker Tel: 083 279 0734 / 035-905 3638.

All tender related queries pertaining to this invitation may be addressed to;
 Mr. Eddie Quinn, Tel: 035 # 905 3664.

The closing time for receipt of your official quotations is 12:00 hours on Friday, 24 October 2014.

PREVIEW COPY



Transnet SOC Limited
Transnet RME
 BOARD LIST TFR RME
 TRANSNET FREIGHT RAIL - RME
 PROCUREMENT DEPARTMENT
 2000
 YOUR VAT NUMBER WITH US: NOT

REQUEST FOR QUOTATION

Registration Number: 1990/000900/06
Vat Number : 4720103177

Attention:
 TFR Official Tender Board.
 Telephone Number :
 Fax Number :
 Vendor Number :2004815

Quotation Deadline Date : 24.10.2014
Quotation Deadline Time : 12:00

REQUEST for QUOTATION
 Transnet RME
RFQ Number / Date
 6000210084 / 16.10.2014
Contact Person / Telephone
 Eddie Quinn / 086 515 905 3664
Return to V / X Number/EMAIL
 0865159978 / TCPtendersRichardsBay@Transnet.net

Item	Material	Description	RFQ Qty	UoM	Required Del date	Confirm Del date	Unit Price Excl	Total Price Excl
------	----------	-------------	---------	-----	-------------------	------------------	-----------------	------------------

Transnet desires a validity period of 90 (Ninety) days from the closing date of this RFQ.

Telephonic and late quotes will not be accepted.
 All quotations should be clearly marked, and may be forwarded to:
 Me Yogeshnie Gengan, Tender & Fax Assistant,
 Fax No: 086 515 9978 and / or
 e-mailed to: TCPtendersRichardsBay@transnet.net

The contractor's address and identification details have to be shown on each quotation submitted.

Please submit the following documents with your quotation;
 • Valid Tax Clearance certificate.
 • Copy of your latest B.B.B.E.E. Certificate.

Failing to submit any of the documents mentioned above, could result in your quotation to be disqualified / not accepted.

Note: #Transnet may not necessarily accept the lowest or any other offer and reserves the right to select in its favor any or, a portion of any offer made"

If you have been contacted directly by the Supply Chain Office (Via a RFQ.), and you are unable to quote for these items, please submit a NO QUOTE.

Otherwise we look forward to receive your detailed quote by the date and time stated.

Yours faithfully,

PREVIEW COPY

N.B.

!!!



Transnet SOC Limited
Transnet RME
 BOARD LIST TFR RME
 TRANSNET FREIGHT RAIL - RME
 PROCUREMENT DEPARTMENT
 2000
 YOUR VAT NUMBER WITH US: NOT

REQUEST FOR QUOTATION

Registration Number: 1990/000900/06
 Vat Number : 4720103177

Attention:

TFR Official Tender Board.
 Telephone Number :
 Fax Number :
 Vendor Number :2004815

Quotation Deadline Date : 24.10.2014
Quotation Deadline Time : 12:00

REQUEST for QUOTATION

Transnet RME
RFQ Number / Date
 6000210084 / 16.10.2014
Contact Person / Telephone
 Eddie Quinn / 085 905 3664
Return to V / X Number/EMAIL
 0865 159978 / TCPtendersRichardsBay@Transnet.net

Item	Material	Description	RFQ Qty	UoM	Required Del date	Confirm Del date	Unit Price Excl	Total Price Excl
------	----------	-------------	---------	-----	-------------------	------------------	-----------------	------------------

Delivery Address

TFR RME Richards Bay
 Old Naval Base, Commodores Clo
 Meerensee, Richards Bay
 3900

This RFQ is subject to the following conditions:

1. Price/s : The price/s quoted in SA currency and is excluding of V.A.T
2. Delivery : The price/s quoted should include delivery cost to the delivery address stated on the RFQ
3. Returnables : A valid tax clearance certificate and BPP/E certificate from a SANAS accredited verification agency attached to quotation for all quotes above R30 000.
Please note that only the official Transnet RFQ will be accepted and all other correspondence to be attached to the original
4. Safety : To confirm to Transnet Capital Projects Health & Safety plan and specification; HAS-std-0001, copy available on request.
5. Confirmation: To confirm your participation in this tender process please sign and return this document as immediate effect prior to the quotation deadline.
6. Negotiations: The Employer may elect to negotiate the final terms of the contract/order with the preferred tenderer in accordance with Clauses F.2.17 and F.3.13 of the CIDB Standard Conditions of Tender. A copy of which is available upon request.

Signature _____

Date _____

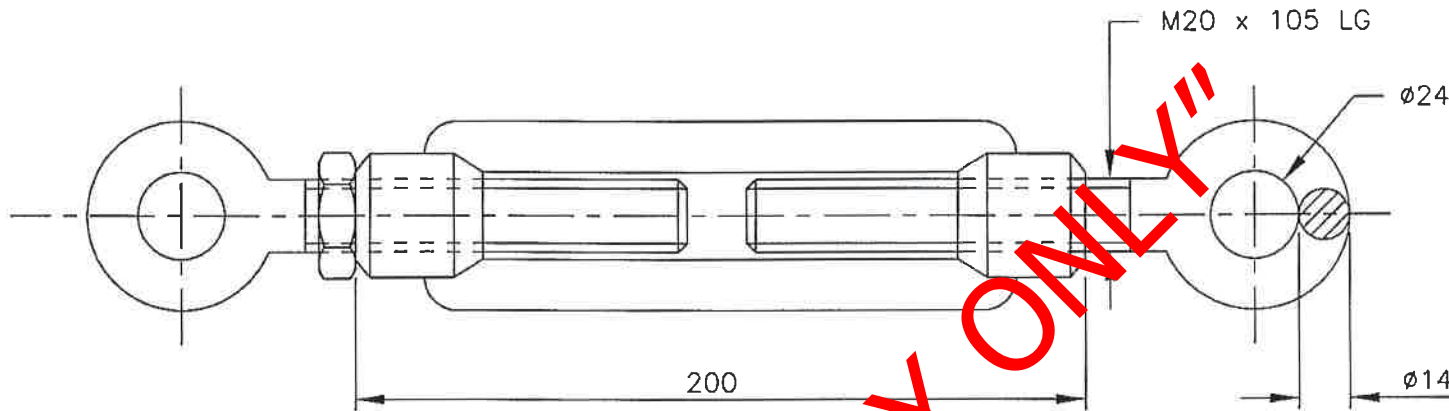

NOTES

1. MAX. WORKING LOAD: 56,25 kN.
2. DRG TO BE READ IN CONJUNCTION WITH ENGINEERING INSTRUCTION B.007.
3. FITTING TO BE PERMANENTLY MARKED WITH MAKERS IDENTIFICATION AND MONTH AND YEAR OF MANUFACTURE.
4. FOR M16 TURNBUCKLE (110 mm TAKE-UP) SEE ITEM 54/1913, DRAWING NO SEE TNB-31.

FINISH

HOT DIP GALVANISE TO SANS 121.

MATERIAL: TURNBUCKLE TO COMPLY WITH DIN 1480.

DO REF: T97/012 GEN TOL: LIN± — ANG± —

DRN: A.PIETERSE CKD: JVT DATE: 97-09-18

J.HARCUS for ENG J.P. du PLESSIS for CHIEF ENG

CENTRAL DRAWING OFFICE  SPOORNET

M20 TURNBUCKLE
130 mm TAKE-UP

AMENDMENTS

NO	NAME	DATE
1	JVT	97-11-28

LOCK NUT ADDED.
DO REF: T97/027

2	J.HARCUS	98-03-27
---	----------	----------

TAKE-UP WAS 120.
NOTE 4 ADDED.
DO REF: T98/014

3		21/04/06
---	---	----------

DRAWING REVISED.
FINISH WAS ZINC
COAT TO SPEC
SABS 763 FOR
CONDITIONS IN SITU.
ECP REF: BBC1787
DO REF: CDO5065

STORES ITEM NO
54/31523

DIMENSIONS: mm
SCALE: 1:2



DRG NO CEE-
TNB-79

SHT — OF —

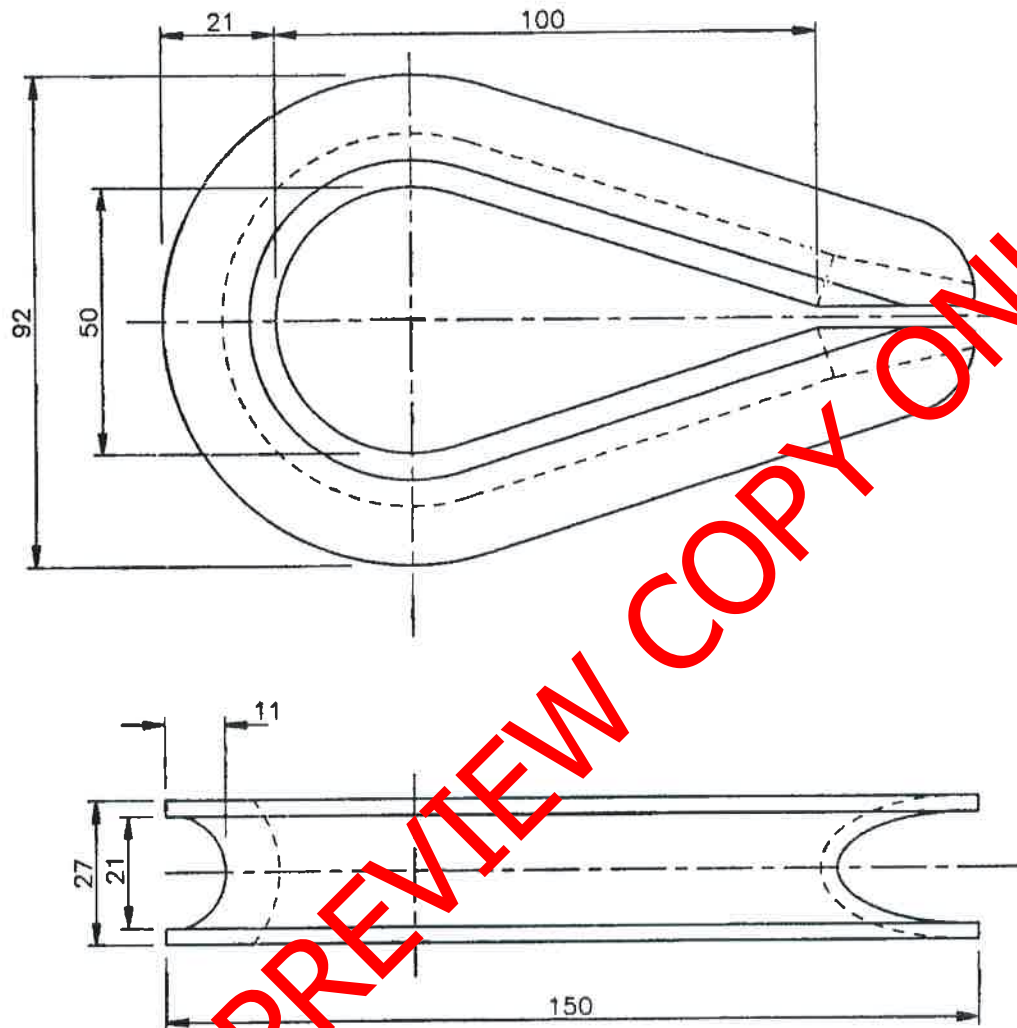

"PREVIEW COPY ONLY"

FINISH
ZINC COAT TO SABS 763 FOR CONDITIONS IN SITU

AMENDMENTS

NO	NAME	DATE
1	JVT	95-09-11

REVISED, DRG NO WAS
CEE-TN-394.
DO REF: T95/052

MATERIAL: ITEM NO 11/ ———, STEEL SEE SPEC SABS 811

DO REF: J27/68 GEN TOL: LIN± 0,4 ANG± —

DRN: L. N. CKD: E.F.J. DATE: 68-03-27

ENG: D.D.M.C. W PHILLIPS for CHIEF ENG

INFRASTRUCTURE
(ELECTRICAL)



ROPE THIMBLE
Ø22mm WIRE

DIMENSIONS: mm
SCALE: 1:1



DRAWING NO CEE-
TNB-39
SHEET — OF —

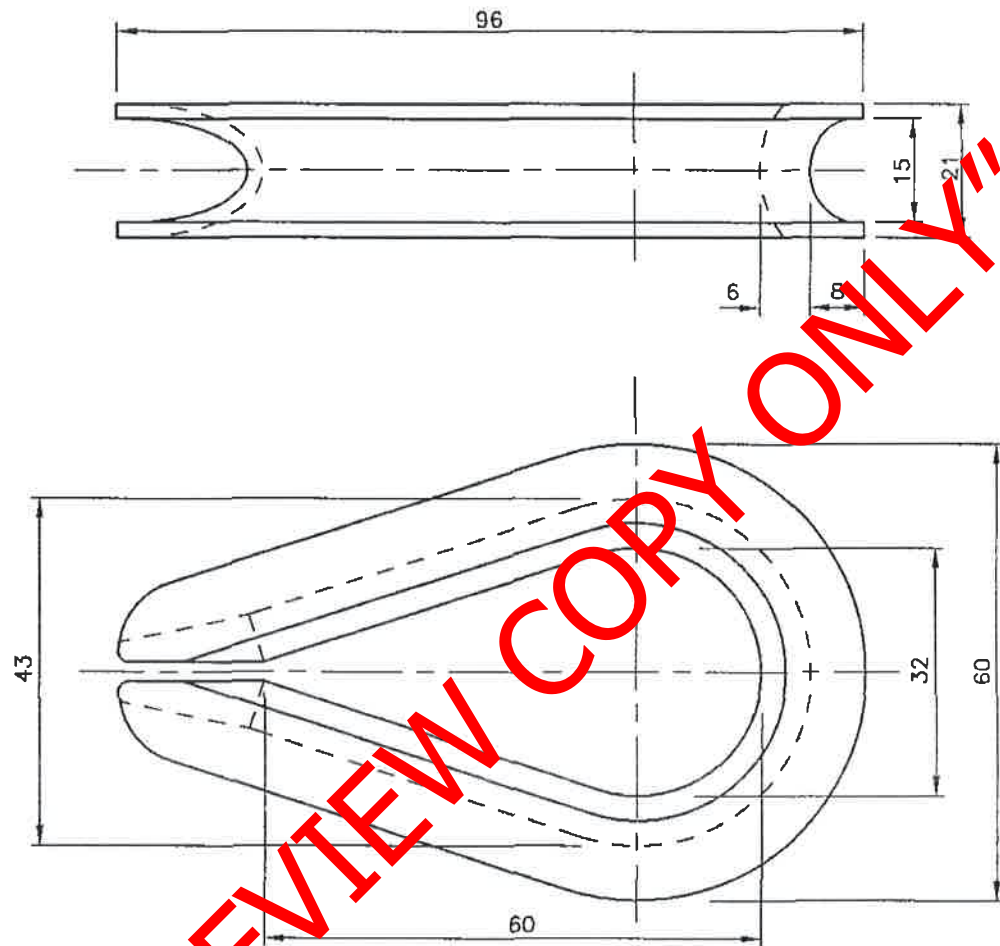

"PREVIEW COPY ONLY"

FINISH

ZINC COAT TO SABS 763 FOR CONDITIONS IN SITU.

AMENDMENTS

NO	NAME	DATE
1	JVT	2000-10-30

REVISED, DRG NO WAS CEE-TN-292. DO REF: T96/001

STORES ITEM NO. 54/5264

DIMENSIONS: mm
SCALE: NTS

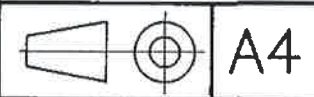

MATERIAL: ITEM NO 11/ ———, STEEL SEE SPEC SABS 811

DO REF: J27/68 GEN TOL: LIN± 0,5 ANG± 1°

DRN: L N CKD: E F J DATE: 68-03-27

ENG: D McKAY W PHILLIPS for CHIEF ENG

ROPE THIMBLE

WIRE SIZE - 100mm²

CENTRAL DRAWING OFFICE  SPOORNET

DRG NO CEE-TNB-85

SHT — OF —