



Transnet SOC Limited  
Transnet RME

REQUEST FOR QUOTATION

BOARD LIST TFR RME  
TRANSNET FREIGHT RAIL - RME  
PROCUREMENT DEPARTMENT  
2000

Registration Number: 1990/000900/06  
Vat Number : 4720103177

**Attention:**  
  
Telephone Number :  
Fax Number :  
Vendor Number :2004815

**Quotation Deadline Date : 02.07.2014**  
**Quotation Deadline Time : 16H00**

**REQUEST for QUOTATION**  
Transnet RME  
**RFQ Number / Date**  
6000200790 / 25.06.2014  
**Contact Person / Telephone**  
Anne Mongie / 031 361 1759  
**Return to VAX Number/EMAIL**  
0318300101 / TCPtendersDurban@Transnet.net

"PREVIEW COPY ONLY"

Item	Material	Description	RFQ Qty	UoM	Required Del date	Confirm Del date	Unit Price Excl	Total Price Excl
00010		WIRE 4/4MM STEEL GALVAN	300	ea	09.07.2014			
		WIRE 4/4MM STEEL GALVANISED						
00020		WIRE DROPPER 4MM SS ANN	5	Ro	09.07.2014			
		WIRE DROPPER 4MM SS ANNEALED 100M ROLL						
00030		THIMBLE 10MM TO SABS 11	100	ea	09.07.2014			
		THIMBLE 10MM TO SABS 11 TABLE 1						



**Transnet SOC Limited**  
**Transnet RME**  
 BOARD LIST TFR RME  
 TRANSNET FREIGHT RAIL - RME  
 PROCUREMENT DEPARTMENT  
 2000  
 YOUR VAT NUMBER WITH US: NOT

**REQUEST FOR QUOTATION**

**Registration Number: 1990/000900/06**  
**Vat Number : 4720103177**

**Attention:**  
  
 Telephone Number :  
 Fax Number :  
 Vendor Number :2004815

**Quotation Deadline Date : 02.07.2014**  
**Quotation Deadline Time : 16H00**

**REQUEST for QUOTATION**  
 Transnet RME  
**RFQ Number / Date**  
 6000200790 / 25.06.2014  
**Contact Person / Telephone**  
 Anne Mongie / 031 361 1759  
**Return to VAX Number/EMAIL**  
 0318300101 / TCPtendersDurban@Transnet.net

Item	Material	Description	RFQ Qty	UoM	Required Del date	Confirm Del date	Unit Price Excl	Total Price Excl
00040		WIRE ROPE CLAMP M12x60m	300	ea	09.07.2014			
		WIRE ROPE CLAMP M12x60mm <sup>2</sup> HT GI CROSSB						
00050		DROPPER SADDLE 160mm <sup>2</sup> C	3,000	ea	09.07.2014			
		DROPPER SADDLE 160mm <sup>2</sup> CATENARY TND-5						

"PREVIEW COPY ONLY"

FOR MORE INFORMATION PLEASE CONTACT THOBEKA 0837791651

QUOTES MUST BE SENT TO : TCPtendersDurban@transnet.net  
 CLOSING DATE 2 JULY 2014 AT 16H00.  
 KINDLY ATTACH COPIES OF BBBEE AND TAX CLEARANCE CERTIFICATES  
 ALL PROCUREMENT RELATED QUERIES MUST BE SENT TO :  
 ANNE MONGIE : 031 361 1759  
 E-MAIL : anne.mongie@transnet.net



Transnet SOC Limited  
 Transnet RME  
 BOARD LIST TFR RME  
 TRANSNET FREIGHT RAIL - RME  
 PROCUREMENT DEPARTMENT  
 2000  
 YOUR VAT NUMBER WITH US: NOT

## REQUEST FOR QUOTATION

Registration Number: 1990/000900/06  
 Vat Number : 4720103177

**Attention:**

Telephone Number :  
 Fax Number :  
 Vendor Number :2004815

**Quotation Deadline Date : 02.07.2014**  
**Quotation Deadline Time : 16H00**

**REQUEST for QUOTATION**

Transnet RME

**RFQ Number / Date**

6000200790 / 25.06.2014

**Contact Person / Telephone**

Anne Mongie / 031 361 1759

**Return to VAX Number/EMAIL**

0318300001 / TCPtendersDurban@Transnet.net

**Delivery Address**

TFR RME Durban  
 100 Eel Road  
 Bayhead, Durban  
 4001

This RFQ is subject to the following conditions:

1. Price/s : The price/s quoted in SA currency and is excluding of V.A.T.
2. Delivery : The price/s quoted should include delivery cost to the delivery address stated on the RFQ
3. Returnables : A valid tax clearance certificate and BBBEE certificate from a SANAS accredited verification agency attached to quotation for all quotes above R30 000.  
Please note that only the official Transnet RFQ will be accepted and all other correspondence to be attached to the original
4. Safety : To confirm to Transnet Capital Projects Health & Safety plan and specification; HAS-std-0001, copy available on request.
5. Confirmation: To confirm your participation in this tender process please sign and return this document as immediate effect prior to the quotation deadline.
6. Negotiations: The Employer may elect to negotiate the final terms of the contract/order with the preferred tenderer in accordance with Clauses F.2.17 and F.3.13 of the CIDB Standard Conditions of Tender. A copy of which is available upon request.

\_\_\_\_\_  
 Signature

\_\_\_\_\_  
 Date

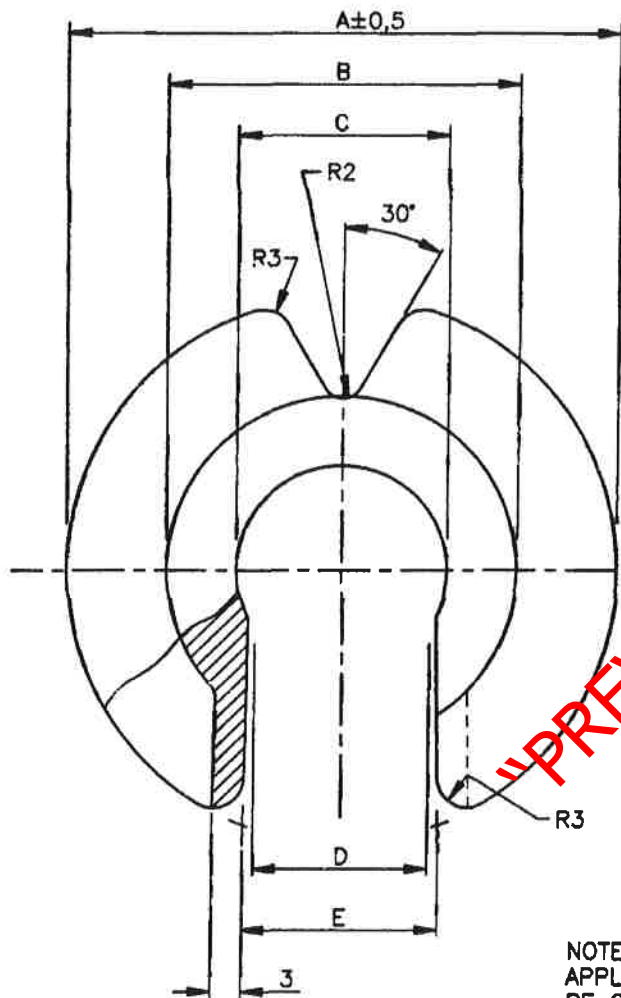

CATENARY	A	B	C	D	E	ITEM NO
80mm <sup>2</sup>	∅38	∅15	∅10,8	9,6	9 <sup>+1</sup> <sub>0</sub>	54/6840
100mm <sup>2</sup>	∅40	∅20,1	∅12,1	10,7	10 <sup>+1</sup> <sub>0</sub>	54/16861
* 160mm <sup>2</sup>	∅46,5	∅26,4	∅15,9	14,1	13 <sup>+2</sup> <sub>0</sub>	54/16836
250mm <sup>2</sup>	∅54	∅33,9	∅20,5	18,2	16 <sup>+3</sup> <sub>0</sub>	54/16848
** 530mm <sup>2</sup>	∅68	∅48,1	∅29,4	26	25 <sup>+4</sup> <sub>0</sub>	54/31701

\* ALSO FOR CONDUCTOR (ACSR) CODE NAME "TIGER"

\*\* FOR CONDUCTOR (ACSE) CODE NAME "DEER"

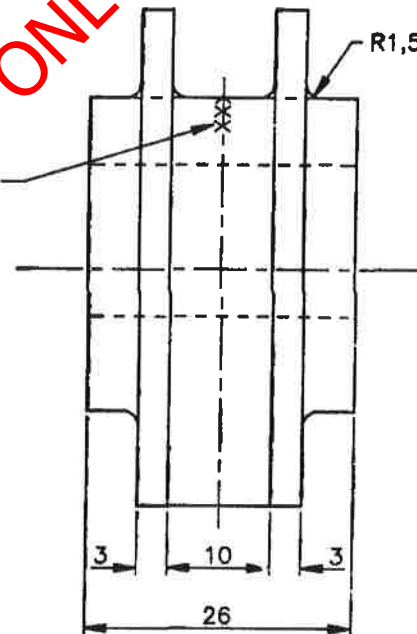

NOTE  
 APPLICABLE CONDUCTOR SIZE 80-, 100-, 160-, 250- OR 530mm<sup>2</sup> TO  
 BE CAST OR PUNCHED IN POSITION SHOWN (3mm CHARACTER HEIGHT).

AMENDMENTS		
NO	NAME	DATE
1	I DE VILLIERS	90-02-14
REDRAWN, INFORMATION ADDED. DO REF: T90/009		
2	I DE VILLIERS	91-03-04
INDICATION OF CONDUCTOR SIZE MOVED. DO REF: T91/010		
3	W BRIGHT	92-06-22
DIMENSION "E" WAS 10,1 ; 11,3 ; 14,8 AND 19. DO REF: T92/027		
4	H A SLIER	98-06-04
DRAWING REVISED AND INFORMATION ADDED. DO REF: T98/024		

MATERIAL: NYLON 66, PIGMENT: BLACK

DO REF T90/001 GEN TOL: LIN± 0,2 ANG± 0°30'

DRN J VON ABO CKD J H SWIEGERS DATE 90-01-29

ENG A VERSTEEG A VERSTEEG for CHIEF ENG

INFRASTRUCTURE  
(ELECTRICAL)

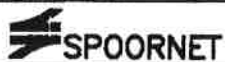

**DROPPER CLIP**

CLIP-ON TYPE

80-, 100-, 160-, 250- & 530mm<sup>2</sup> CATENARIES

DIMENSIONS:mm  
SCALE 2:1



A3

DRAWING NC CEE-

TND-5

SHEET - OF -