



Transnet SOC Limited
Transnet RME

REQUEST FOR QUOTATION

BOARD LIST TFR RME
TRANSNET FREIGHT RAIL - RME
PROCUREMENT DEPARTMENT
2000

Registration Number: 1990/000900/06
Vat Number : 4720103177

Attention:

Telephone Number :
Fax Number :
Vendor Number :2004815

Quotation Deadline Date : 02.05.2014
Quotation Deadline Time : 16H00

REQUEST for QUOTATION
Transnet RME
RFQ Number / Date
6000195871 / 24.04.2014
Contact Person / Telephone
Anne Mongie / 031 361 1759
Return to VAX Number/EMAIL
0318300001 / TCPtendersDurban@Transnet.net

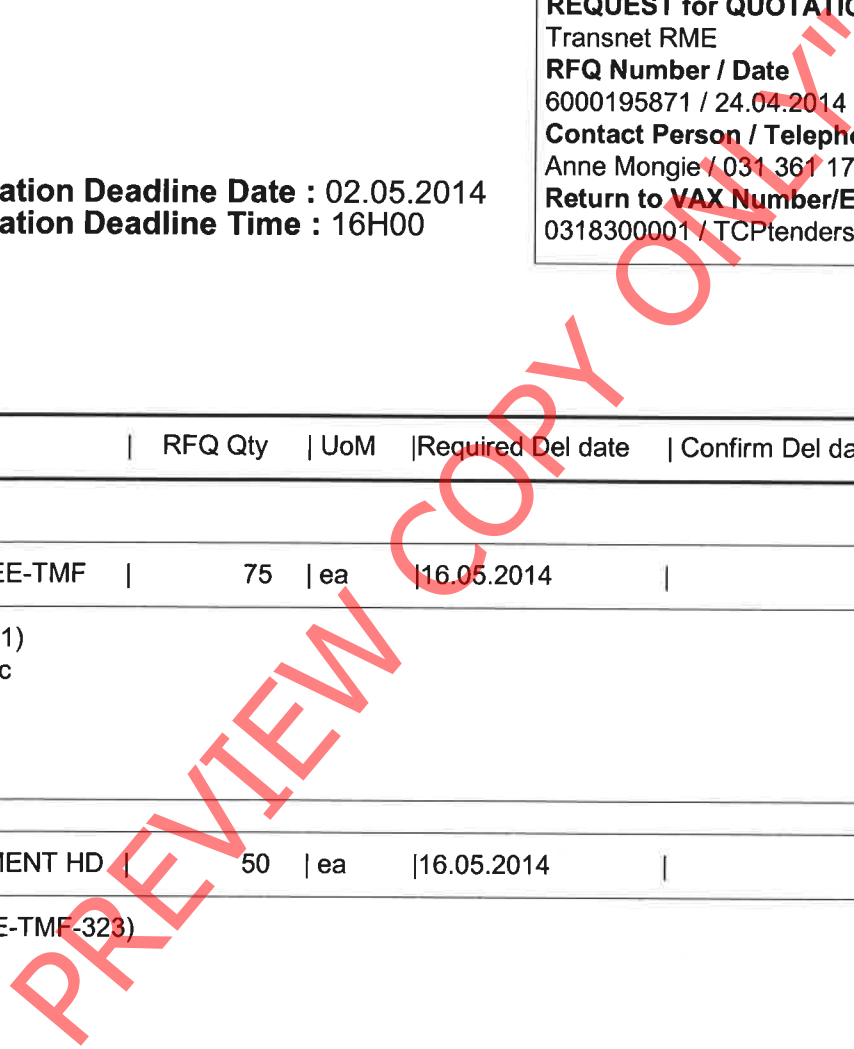

Item	Material	Description	RFQ Qty	UoM	Required Del date	Confirm Del date	Unit Price Excl	Total Price Excl
00010		CROSS ARM 11kV (CEE-TMF CROSS ARM 11kV (CEE-TMFB-61 SH1) Items 1 & 2 Only Complete HDG 240 Hc	75	ea	16.05.2014			
00020		STAY WIRE ATTACHMENT HDG STAY WIRE ATTACHMENT HDG (CEE-TMF-323)	50	ea	16.05.2014			
00030		BACKSTRAP HDG	300	ea	16.05.2014			



Transnet SOC Limited
 Transnet RME
 BOARD LIST TFR RME
 TRANSNET FREIGHT RAIL - RME
 PROCUREMENT DEPARTMENT
 2000
 YOUR VAT NUMBER WITH US: NOT

REQUEST FOR QUOTATION

Registration Number: 1990/000900/06
 Vat Number : 4720103177

Attention:
 Telephone Number :
 Fax Number :
 Vendor Number :2004815

Quotation Deadline Date : 02.05.2014
Quotation Deadline Time : 16H00

REQUEST for QUOTATION
 Transnet RME
RFQ Number / Date
 6000195871 / 24.04.2014
Contact Person / Telephone
 Anne Mongie / 031 361 1759
Return to VAX Number/EMAIL
 0318300001 / TCPtendersDurban@Transnet.net

Item	Material	Description	RFQ Qty	UoM	Required Del date	Confirm Del date	Unit Price Excl	Total Price Excl
		BACKSTRAP HDG (CEE-TMFB-145)						
00040		ANCHOR FITTING HDG	50	ea	16.05.2014			
		ANCHOR FITTING HDG (CEE-TMFB-50)						
00050		BACKSTRAP MAKE-OFF FITT	50	ea	16.05.2014			

BACKSTRAP MAKE-OFF FITTING HDG (CEE-TMFB-51)
 FOR MORE INFORMATION PLEASE CONTACT THOBEKA 0837791651
 DELIVERY : 130 EEL ROAD BAYHEAD DURBAN

QUOTES MUST BE SENT TO : TCPtendersDurban@transnet.net or faxed to : 031 361 1783.
 KINDLY ATTACH COPIES OF BBBEE AND TAX CLEARANCE CERTIFICATES. CLOSING DATE : 2 MAY 2014 AT 16H00.
 ALL PROCUREMENT RELATED QUERIES TO BE DIRECTED TO :
 ANNE MONGIE : 031 361 1759
 E-MAIL : anne.mongie@transnet.net



Transnet SOC Limited
 Transnet RME
 BOARD LIST TFR RME
 TRANSNET FREIGHT RAIL - RME
 PROCUREMENT DEPARTMENT
 2000
 YOUR VAT NUMBER WITH US: NOT

REQUEST FOR QUOTATION

Registration Number: 1990/000900/06
 Vat Number : 4720103177

Attention:

Telephone Number :
 Fax Number :
 Vendor Number :2004815

Quotation Deadline Date : 02.05.2014
Quotation Deadline Time : 16H00

REQUEST for QUOTATION

Transnet RME
RFQ Number / Date
 6000195871 / 24.04.2014
Contact Person / Telephone
 Anne Mongie / 031 361 1759
Return to VAX Number/EMAIL
 0318300001 / TCPtendersDurban@Transnet.net

Item	Material	Description	RFQ Qty	UoM	Required Del date	Confirm Del date	Unit Price Excl	Total Price Excl
------	----------	-------------	---------	-----	-------------------	------------------	-----------------	------------------

Delivery Address

TFR RME Durban
 100 Eel Road
 Bayhead, Durban
 4001

This RFQ is subject to the following conditions:

1. Price/s : The price/s quoted in SA currency and is excluding of V.A.T.
2. Delivery : The price/s quoted should include delivery cost to the delivery address stated on the RFQ
3. Returnables : A valid tax clearance certificate and BBEE certificate from a SANAS accredited verification agency attached to quotation for all quotes above R30 000.
Please note that only the official Transnet RFQ will be accepted and all other correspondence to be attached to the original
4. Safety : To confirm to Transnet Capital Projects Health & Safety plan and specification; HAS-std-0001, copy available on request.
5. Confirmation: To confirm your participation in this tender process please sign and return this document as immediate effect prior to the quotation deadline.
6. Negotiations: The Employer may elect to negotiate the final terms of the contract/order with the preferred tenderer in accordance with Clauses F.2.17 and F.3.13 of the CIDB Standard Conditions of Tender. A copy of which is available upon request.

Signature _____

Date _____

10383188

ITEM	DESCRIPTION	QTY	STORES ITEM NO	DRAWING NO. CEE-	AMENDMENTS
1	CROSS ARM, PHASE WIRE SUPPORT			TMFB-61 SHT 2	NO NAME DATE
2	SUPPORT, EARTH WIRE			TMFB-61 SHT 3	
3	SUPPORT BRACKET ASSEMBLY			TMFB-62 SHT 1	

NO	NAME	DATE
4	LBORCHARD	92-06-18
REDRAWN AND REVISED TO FIT CONCRETE MAST. DRG NO WAS CEE-PFC-80. DO REF P92/013		
5	J VAN DYK	94-05-26
SUB-TITLE REVISED. DO REF T94/023		
6	J P du PLESSIS	94-09-15
DETAIL WITH DIMENSION 21mm ADDED. DO REF T94/064		

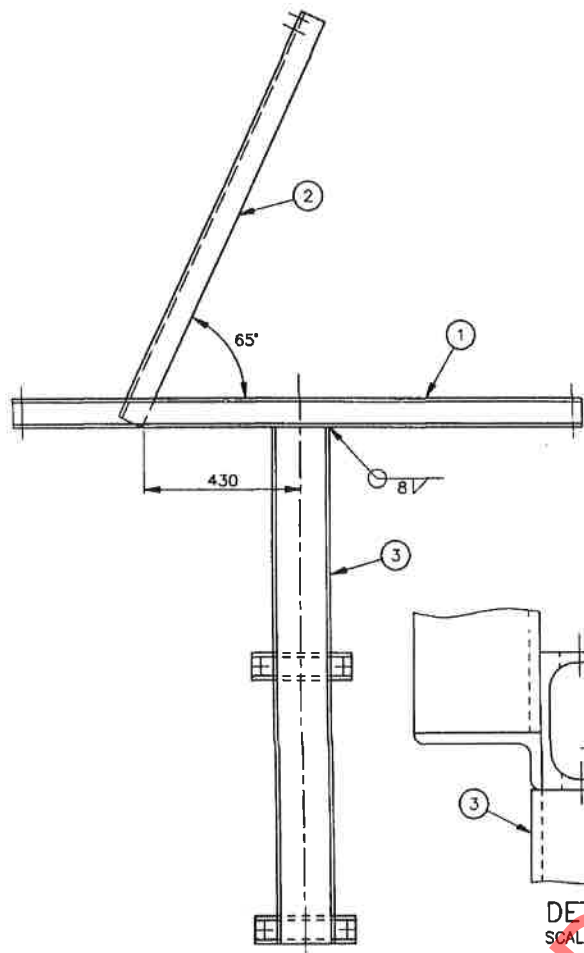

CONCRETE MAST ARRANGEMENT

DETAIL
SCALE 1:2

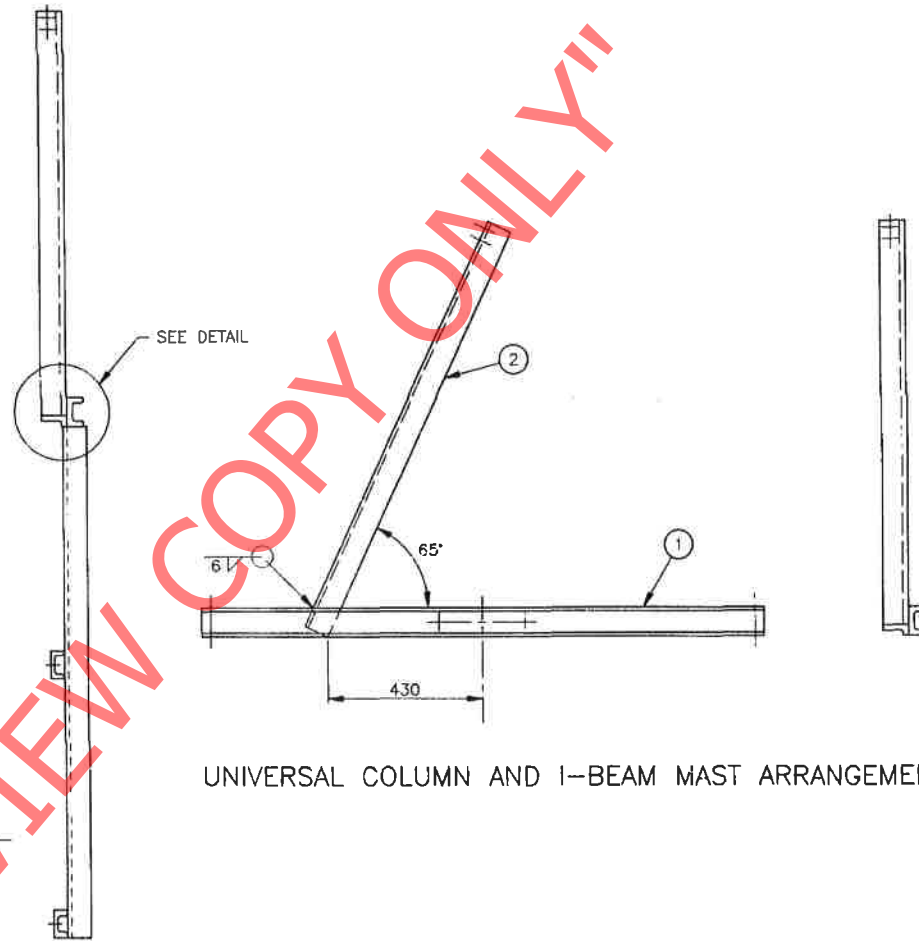

UNIVERSAL COLUMN AND I-BEAM MAST ARRANGEMENT

NOTES
1. ZINC COAT TO SPEC SABS 763 AFTER WELDING.

DO REF Y.76/43	GEN TOL: LIN± 1	ANG± 1'
DRN B.v.RENSBURG	CKD W.R.G.	DATE 78-03-31
ENG I.DE V.	F.PIENAAR	for CHIEF ENG
INFRASTRUCTURE (ELECTRICAL)	SPOORNET	

CROSS ARM STRUCTURE ASSEMBLY
11kV TRANSMISSION LINE ON OHTE MAST
UNIVERSAL COLUMN, I-BEAM AND CONCRETE MAST

DIMENSIONS: mm
SCALE 1:10

A2

DRAWING NO CEE-
TMFB-61
SHEET 1 OF 3

10000556

10383189

ORIGINAL FRAME SIZE. OORSPRONKLIKE RAAMGROOTTE. 267 x 180		ITEM	DESCRIPTION. BESKRYWING.	QTY. HYLD.	STORES ITEM. WAGBASTYTEM.	DRG. NO. C.E.E. TEK. NO. C.E.E.	AMENDMENTS. WYSIGINGS.		
NO.	NAME. NAAM.	DATE. DATUM.							
1.	BRACKET. STEUN.			1		TMHA-154. ITEM. 2.	1.	A.J.V.	02-03-30
2.	GUSSET PLATE. KNOOPPLAAT.			2.		TMHF-16.			

FINISH : ZINC COAT TO SPEC.
AFWERKING : SINKBEDEK VOLGENS SPES. S.A.B.S. 763.

DIMENSIONS : MILLIMETRES. AFMETINGS : MILLIMETER.		GEN. TOLERANCES : LIN. ± 1. ALG. TOLERANSIES : ANG. / HOEK. —	
DRN. R. KIECK. GET.	TRCD. R. KIECK. NGT.	D.O. REF. TK-VERW. Y70/95	ENG. IR.
CHK. NGS J. JACKSON	DATE. 79-11-22	DATE. 79-11-22	

STAY WIRE ATTACHMENT.
203 x 203 UNIVERSAL COLUMNS.
ANKERDRAAD - HEGSTUK.
203 x 203 UNIVERSELE KOLONNIE.

ASSY. DRG. NO'S
ADDED.
SAMEST. TEK. NRS
BYGEVOEG.
D.O. REF P82/10
TK-VERW

CEE-PFB-18
CEE-PFB-19
CEE-PFB-20
CEE-TP-154.
CEE-TU-51.
CEE-TMG-77-SHT1/2
C.E.E. TMG-78-SHT1/2.
ASSY DRG./SAMEST. TEK.

DRAWING NO. CEE.
TEKENING NO. CEE.
TMF-323.

3

4

4

3

10383190

AMENDMENTS		
NO	NAME	DATE
1	JVT	97-09-05
REVISED, DRAWING NO WAS TMHA-90. DO REF: T96/021		

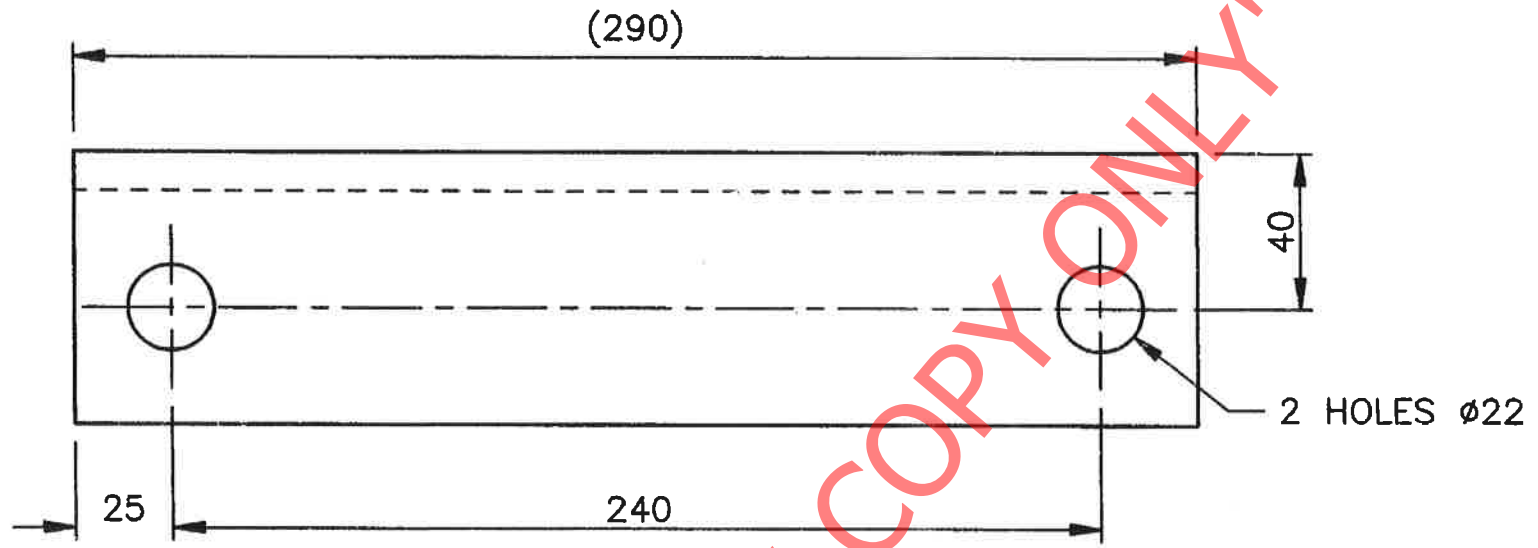

FINISH
 ITEM 1: ZINC COAT TO SABS 763 FOR CONDITIONS IN SITU.
 ITEM 2: NOT ZINC COATED.

DIMENSIONS: mm
 SCALE: 1:2

MATERIAL: STORES ITEM NO: 11/14508, STEEL, ANGLE, 70 x 70 x 10 x 290 LG.

DO REF: Y76/43	GEN TOL: LIN± 1,5	ANG± -
DRN: B v RENSBERG	CKD: W.R.G.	DATE: 78-03-31
for ENG: I DE V	F PIENAAR	for CHIEF ENG

CLAMPING BRACKET
 203 x 203 UNIVERSAL COLUMNS



DRG NO **CEE-
 TMFB-145**
 SHT - OF -

INFRASTRUCTURE
 (ELECTRICAL)



10383191

PREVIEW COPY ONLY

2 HOLES $\varnothing 26$

3 HOLES $\varnothing 18$

FINISH
ZINC CCAT TO SPEC SABS 763

AMENDMENTS		
NO	NAME	DATE

STORES ITEM NO

DIMENSIONS mm
SCALE 1:5

MATERIAL, ITEM NO 11/14570 STEEL ANGLE 100x100x15THK x315L SPEC CME 9 SYM 8

DO REF T92/002	GEN TOL, LIN# 1	ANG# -	ANCHOR FITTING, CONTACT & CATENARY
DRN J VON ABO	CKDH v VUUREN	DATE 92-03-03	
ENG HA SLIER	A VERSTEEG	for CHIEF ENG	

INFRASTRUCTURE (ELECTRICAL) **SPOORNET** UNIVERSAL COLUMNS STAY WIRE CONSTRUCTION

	A4
DRG NO	CEE-TMFB-50
SHT	- OF -

3

4

4

4

4

3

10383192

315

40

35

245

2 HOLES ø26

FINISH
ZINC COAT TO SPEC SABS 763

AMENDMENTS		
NO	NAME	DATE

STORES ITEM NO

DIMENSIONS: mm
SCALE 1:2

MATERIAL, ITEM NO 11/14508 STEEL ANGLE 70x70x10THK x315L SPEC CME 9 SYM 8

DO REF T92/002	GEN TOL. LINE 1	ANG± -
DRN J VON ABO	CKDH v VUUREN	DATE 92-03-03
ENG HA SLIER	A VERSTEEG	for CHIEF ENG

BACK ANGLE, CONTACT & CATENARY ANCHOR

UNIVERSAL COLUMNS
STAY WIRE CONSTRUCTION

INFRASTRUCTURE (ELECTRICAL)

SPOORNET

DRG NO **CEE-TMFB-51**

SHT - OF -

A4

3

Δ

4

4

Δ

3