



Transnet SOC Limited  
Transnet RME

REQUEST FOR QUOTATION

BOARD LIST TFR RME  
TRANSNET FREIGHT RAIL - RME  
PROCUREMENT DEPARTMENT  
2000

Registration Number: 1990/000900/06  
Vat Number : 4720103177

**Attention:**  
TFR Official Tender Board.  
Telephone Number :  
Fax Number :  
Vendor Number :2004815

**Quotation Deadline Date : 13.12.2013**  
**Quotation Deadline Time : 12:00**

**REQUEST for QUOTATION**  
Transnet RME  
**RFQ Number / Date**  
6000184101 / 04.12.2013  
**Contact Person / Telephone**  
Eddie Quinn / 035 905 3664  
**Return to VAX Number/EMAIL**  
0865159978 / TCPtendersRichardsBay@Transnet.net

*N.B.*

PLEASE ONLY RESPOND / QUOTE TO:

The Chairman of the Acquisition Council;  
Fax: 011 – 774 9760 or 774 9129 or 774 9186.

Item	Material	Description	RFQ Qty	UoM	Required Del date	Confirm Del date	Unit Price Excl	Total Price Excl
00010		Manufacture Double Boom	1	ea	21.01.2014			
Manufacture, deliver and Offload, 1 x Double Boom as per attached Drawing No: CEE-TMC-21 Sheet: 1. Length of Boom 17,240m. Boom Joint to be done as indicated on drawing. Deliver to 1 Morris Road - Empangeni Rail - OHTE Store. Stores Contact: Mr Jos Talanda Tel: 083 279 0653. Contact: Mr Pierre Crocker Tel: 035-905 3638 / 083 279 0437.								
00020		Manufacture Double Boom	1	ea	21.01.2014			
Manufacture, Deliver & Offload, 1 x Double Boom as per the attached Drawing No: CEE-TMC-21 Sheet: 1. Length of Boom: 18,650m. Boom Joint to be done as indicated on drawing Deliver to 1 Morris Road - Empangeni Rail - OHTE Store. Stores Contact: Mr Jos Talanda Tel: 083 279 0653. Contact: Mr Pierre Crocker Tel: 035-905 3638 / 083 279 0437.								



Transnet SOC Limited  
 Transnet RME  
 BOARD LIST TFR RME  
 TRANSNET FREIGHT RAIL - RME  
 PROCUREMENT DEPARTMENT  
 2000  
 YOUR VAT NUMBER WITH US:

## REQUEST FOR QUOTATION

Registration Number: 1990/000900/06  
 Vat Number : 4720103177

**Attention:**

TFR Official Tender Board.  
 Telephone Number :  
 Fax Number :  
 Vendor Number :2004815

**Quotation Deadline Date : 13.12.2013**  
**Quotation Deadline Time : 12:00**

**REQUEST for QUOTATION**

Transnet RME

**RFQ Number / Date**

6000184101 / 04.12.2013

**Contact Person / Telephone**

Eddie Quinn / 035 905 3664

**Return to VAX Number/EMAIL**~~0865159978 / TCPtendersRichardsBay@Transnet.net~~

Item	Material	Description	RFQ Qty	UoM	Required Del date	Confirm Del date	Unit Price Excl	Total Price Excl
------	----------	-------------	---------	-----	-------------------	------------------	-----------------	------------------

Transnet Limited t/a Transnet Freight Rail (R.M.E.) # Richards Bay, hereby invite your company to submit a detailed quotation for:

The Manufacture, Deliver & Offload, 2 x Double Booms, Different Lengths, as per the attached Drawing No: CEE-TMC-21 Sheet: 1, as requested above.

All technical queries relating to this invitation may be addressed to;  
 Mr. Pierre Crocker Tel: 035-905 3638 / 083 279 0437.

All tender related queries pertaining to this invitation may be addressed to;  
 Mr. Eddie Quinn, Tel: 035 # 905 3664.

The closing time for receipt of your official quotations is 12:00 hours on Wednesday, 13 December 2013.

Telephonic and late quotes will not be accepted.

All quotations should be clearly marked, and forwarded to:

· The Chairman of the Acquisition Council  
 Fax numbers: 011-774 9760, 011-774 9129 or 011-774 9186,

or

· Transnet Freight Rail (RME)  
 The Chairman of the Acquisition Council  
 Inyanda House 1  
 21 Wellington Rd  
 Parktown, Gauteng



Transnet SOC Limited  
 Transnet RME  
 BOARD LIST TFR RME  
 TRANSNET FREIGHT RAIL - RME  
 PROCUREMENT DEPARTMENT  
 2000  
 YOUR VAT NUMBER WITH US:

REQUEST FOR QUOTATION

Registration Number: 1990/000900/06  
 Vat Number : 4720103177

**Attention:**  
 TFR Official Tender Board.  
 Telephone Number :  
 Fax Number :  
 Vendor Number :2004815

**Quotation Deadline Date : 13.12.2013**  
**Quotation Deadline Time : 12:00**

**REQUEST for QUOTATION**  
 Transnet RME  
**RFQ Number / Date**  
 6000184101 / 04.12.2013  
**Contact Person / Telephone**  
 Eddie Quinn / 035 905 3664  
**Return to VAX Number/EMAIL**  
 0865450978 / TCPtendersRichardsBay@Transnet.net

Item	Material	Description	RFQ Qty	UoM	Required Del date	Confirm Del date	Unit Price Excl	Total Price Excl
------	----------	-------------	---------	-----	-------------------	------------------	-----------------	------------------

The contractor's address and identification details have to be clearly indicated on each quotation submitted.

N.B.

- Please submit the following documents with your quotation;
- Valid Tax Clearance certificate.
  - Copy of your latest B.B.B.E.E. Certificate.

Failing to submit any of the documents mentioned above, could result in your quotation to be disqualified / not accepted.

Note: #Transnet may not necessarily accept the lowest or any other offer and reserves the right to select in its favor any or, a portion of any offer made"

If you have been contacted directly by the Supply Chain Office (Via a RFQ.), and you are unable to quote for these items, please submit a NO QUOTE.

Otherwise we look forward to receive your detailed quote by the date and time stated.

Yours faithfully,

"PREVENTED COPY"



REQUEST FOR QUOTATION

Transnet SOC Limited  
 Transnet RME  
 BOARD LIST TFR RME  
 TRANSNET FREIGHT RAIL - RME  
 PROCUREMENT DEPARTMENT  
 2000  
 YOUR VAT NUMBER WITH US:

Registration Number: 1990/000900/06  
 Vat Number : 4720103177

**Attention:**  
 TFR Official Tender Board.  
 Telephone Number :  
 Fax Number :  
 Vendor Number :2004815

**REQUEST for QUOTATION**  
 Transnet RME  
**RFQ Number / Date**  
 6000184101 / 04.12.2013  
**Contact Person / Telephone**  
 Eddie Quinn / 035 905 3664  
**Return to VAX Number/EMAIL**  
 0865159978 / TCPtenders.RichardsBay@Transnet.net

**Quotation Deadline Date : 13.12.2013**  
**Quotation Deadline Time : 12:00**

N.B.

**Delivery Address**  
 TFR RME Richards Bay  
 Old Naval Base, Commodores Clo  
 Meerensee, Richards Bay  
 3900

PLEASE ONLY RESPOND / QUOTE TO:

The Chairman of the Acquisition Council;  
 Fax: 011 – 774 9760 or 774 9129 or 774 9186.

This RFQ is subject to the following conditions:

1. Price/s : The price/s quoted in SA currency and is excluding of V.A.T
2. Delivery : The price/s quoted should include delivery cost to the delivery address stated on the RFQ
3. Returnables : A valid tax clearance certificate and BBBEE certificate from a SANAS accredited verification agency attached to quotation for all quotes above R30 000.  
 Please note that only the official Transnet RFQ will be accepted and all other correspondence to be attached to the original
4. Safety : To confirm to Transnet Capital Projects Health & Safety plan and specification; HAS-std-0001, copy available on request.
5. Confirmation: To confirm your participation in this tender process please sign and return this document as immediate effect prior to the quotation deadline.
6. Negotiations: The Employer may elect to negotiate the final terms of the contract/order with the preferred tenderer in accordance with Clauses F.2.17 and F.3.13 of the CIDB Standard Conditions of Tender. A copy of which is available upon request.

Signature \_\_\_\_\_

Date \_\_\_\_\_

"PREVIOUS COPY"

REA: 10359245 & 10359246

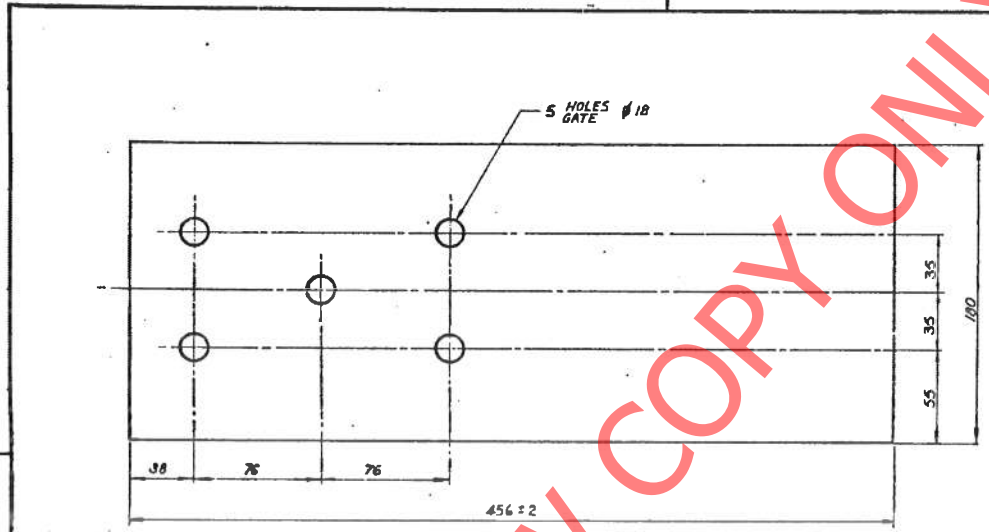

m

AMENDMENTS.  
WYSIGINGS.

NO.	NAME NAAM	DATE DATUM
1.	W. van der Merwe	80-02-20
2.	[Signature]	86-12-22

ASSY. DRG. NO. ADDED.  
SAMEST-TEK. NO. BYGEVOEG.  
D. REF. T80/21.  
TK. VERW.

5 DIA. 18 HOLES REMOVED.  
5 DEURSNEE 18 GATE VERWYDER.  
D. REF. T86/97.  
TK-VERW.

DIMENSIONS: MILLIMETRES  
AFMETINGS: MILLIMETER

MATERIAL-MATERIAAL  
STEEL, PLATE 10 mm THK.  
STAAL, PLAAT 10 mm DIK.  
SPEC. CME @ SYM. 9.  
SPEK. CME @ SIM. 9.  
STOES ITEM NO. (M) 11  
MAGASYNITEM

ZINC COAT TO SPEC.  
SINKBEDEK VOLG SPES. SABS 763.

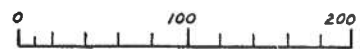

SOUTH AFRICAN TRANSPORT SERVICES  
SUID-AFRIKAANSE VERVOERDIENSTE

DRN. H. COETZEE GET.	GEN. TOLERANCES: L.I.N. 0.1 ALG. TOLERANSIES: ANG./ROEK.
TRCD. L. STEYN AGT.	D. REF. YTB/105 TK. VERW. 105
CRD. MRS. WRS.	DATE 76-11-22 DATUM

CHIEF ELECTRICAL ENGINEER  
ELEKTROTEGNIESE HOOFINGENIEUR  
JOHANNESBURG.

JOINT PLATE, SIDE, INNER.  
DOUBLE BOOMS.  
LASPLAAT, KANT, BINNE.  
DUBBELDWARSBALKE.

CEE TMC-27 SHT./VEL. 1.  
CEE TMC-51 SHT./VEL. 2.  
ASSY. DRG./SAMEST-TEK.

DRAWING NO. CEE  
TEKENING TMHF-81.

2 3 4 4 3 2

REQ: 10359245 246

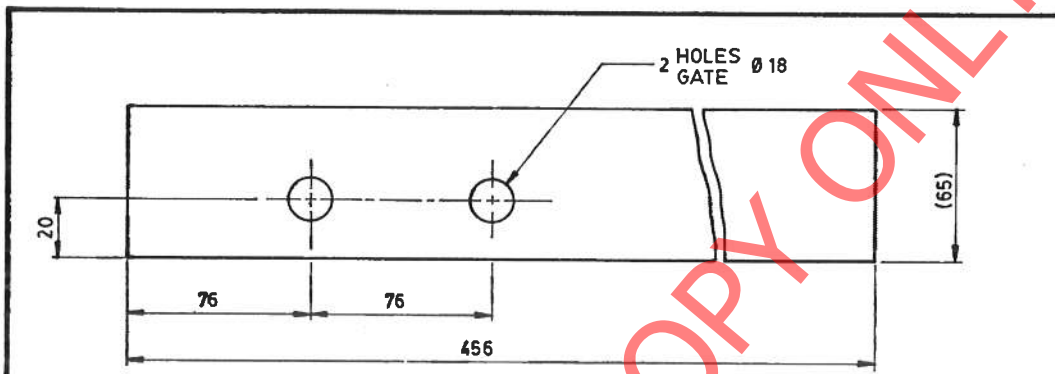

DIMENSIONS: MILLIMETRES  
AFMETINGS: MILLIMETER

MATERIAL / MATERIAAL  
STEEL, FLAT  
STAAL, PLAT 65 x 10 x 456 L

STORES ITEM NO (M) 11/12393  
MAGASYNITEM NO (M) 11/12393

SPEC CME 9 SYM 7  
SPES CME 9 SIM 7

ZINC COAT TO SPEC  
SINKBEDEK VOLG SPES SABS. 763

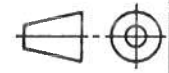
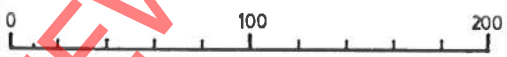

DRN. GET. H. COETZEE.	GEN. TOLERANCES: LIN. ± 1 ALG. TOLERANSIES: ANG/HOEK —
TRCD. NGT. C.B.	D.O. REF. Y 78/109 TK-VERW. IR.
CKD. NGS. W.R.G.	DATE 78-11-22 DATUM PIENAAR for ns.
CHIEF ELECTRICAL ENGINEER JOHANNESBURG ELEKTRIESE HOOFINGENIEUR JOHANNESBURG	
SOUTH AFRICAN TRANSPORT SERVICES SUID-AFRIKAANSE VERVOERDIENSTE	

JOINT, PLATE  
DOUBLE BOOMS  
LASPLAAT  
DUBBEL DWARSBALKE.

AMENDMENTS WYSIGINGS		
NO.	NAME NAAM	DATE DATUM
2		86-12-22
REDRAWN OORGETEKEN DRAWING UPDATED TEKENING BYGEWERK D.O REF T86/97 TK-VERW T86/97		
CEE-TMC-27 SH 1 VEL 1 CEE-TMC-51 SH 2 VEL 2 CLASS/ASSY. DRG. KLAS/SAMEST-TEK. MODULUS ITEM NO.		
PREVIOUS ITEM NO. VORIGE		
DRAWING NO. CEE- TEKENING TMHF-64		

3

Δ

4

Δ

A4

Δ

3