

Transnet SOC Limited
Transnet RME

REQUEST FOR QUOTATION

TRANSNET FREIGHT RAIL - RME
TFR RFQ BOARD-RME
PROCUREMENT DEPARTMENT
PORT ELIZABETH

Registration Number: 1990/000900/06
Vat Number : 4720103177



Attention:

Telephone Number :
Fax Number :
Vendor Number :500000

Quotation Deadline Date : 28.10.2013
Quotation Deadline Time : 16.00

REQUEST for QUOTATION
Transnet RME
RFQ Number / Date
6000178211 / 15.10.2013
Contact Person / Telephone
Yandiswa Oldjohn / 021 940 1911
Return to VAX Number/EMAIL
0218100000 / TCPtendersCapeTown@Transnet.net

Item	Material	Description	RFQ Qty	UoM	Required Del date	Confirm Del date	Unit Price Excl	Total Price Excl
00010		Load & remove +_ 5,000m	1	Lot	01.11.2013			

Load & remove +_ 5,000m3 of spoilt material, clean site and dispose

REQUESTER AND DELIVERY ADDRESS:

DARREL DU PLESSIS- TRANSNET FREIGHT RAIL

COMPULSORY SITE CLARIFICATION MEETING: 21 OCTOBER 2013 AT 12H00.

TENDERERS TO MEET AT TRANSNET PARK, DEAL PARTY, PORT ELIZABETH

CONTACT DARREL DU PLESSIS ON 083-778-1697

If you are unable to quote for this enquiry, please submit a NO QUOTE, with a short reason, if possible, for not being able to quote.

Otherwise we look forward to receive your quote by the date and time stated

Transnet SOC Limited
 Transnet RME
 TRANSNET FREIGHT RAIL - RME
 TFR RFQ BOARD-RME
 PROCUREMENT DEPARTMENT
 PORT ELIZABETH
 6001

REQUEST FOR QUOTATION

Registration Number: 1990/000900/06
 Vat Number : 4720103177

**Attention:**

Telephone Number :
 Fax Number :
 Vendor Number :500000

Quotation Deadline Date : 28.10.2013
Quotation Deadline Time : 16.00

REQUEST for QUOTATION

Transnet RME
RFQ Number / Date
 6000178211 / 15.10.2013
Contact Person / Telephone
 Yandiswa Oldjohn / 021 940 1911
Return to VAX Number/EMAIL
 0218100000 / TCPtendersCapeTown@Transnet.net

Item	Material	Description	RFQ Qty	UoM	Required Del date	Confirm Del date	Unit Price Excl	Total Price Excl
------	----------	-------------	---------	-----	-------------------	------------------	-----------------	------------------

The item covers the following services:

Delivery Address

TFR RME Cape Town
 De Gatt Complex, Behind Propne
 Bellville South, Cape Tow
 7530

This RFQ is subject to the following conditions:

1. Price/s : The price/s quoted in SA currency and is excluding of V.A.T
2. Delivery : The price/s quoted should include delivery cost to the delivery address stated on the RFQ
3. Returnables : A valid tax clearance certificate and BBBEE certificate from a SANAS accredited verification agency attached to quotation for all quotes above R30 000.
Please note that only the official Transnet RFQ will be accepted and all other correspondence to be attached to the original
4. Safety : To confirm to Transnet Capital Projects Health & Safety plan and specification; HAS-std-0001, copy available on request.
5. Confirmation: To confirm your participation in this tender process please sign and return this document as immediate effect prior to the quotation deadline.
6. Negotiations: The Employer may elect to negotiate the final terms of the contract/order with the preferred tenderer in accordance with Clauses F.2.17 and F.3.13 of the CIDB Standard Conditions of Tender. A copy of which is available upon request.

 Signature

 Date

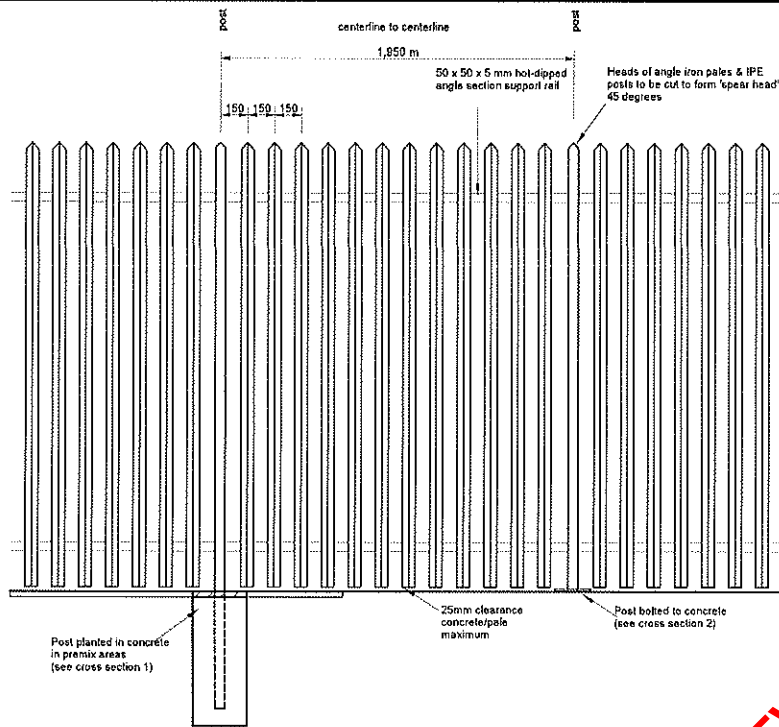

Elevation of Pallisade fence

Scale = 1 : 20

Notes

This drawing is the property of T.N.P.A
Copyright patents and all industrial rights reserved

All written dimensions to take preference over scaled dimensions.
All levels and dimensions to be checked on site before any work commences.

1. SETTING OUT

- The contractor is to set the fence out by survey instrument and as directed by the Technical Officer on site.
No concreting of the posts will be allowed until the entire fence is set out and approved by the Technical Officer.
- 100mm steps in the steel fence panel must be accommodated in the 'post' foundation depth.

2. FOUNDATIONS

- All excavations to be done by hand and contractor to exercise care during excavations as underground services may be encountered.
- Excavations for posts to be neat dimensions of concrete foundation.
- All insitu founding material to be compacted to 93% Mod and inspected by the Technical Officer prior to pouring concrete.

3. CONCRETE

- All concrete to be min 30MPa at 28 days PBFC containing not less than 40% blastfurnace slag or a 50/50 blend of either OPC or PC15 and blastfurnace blend.
- All concrete to be vibrated and cured using acrylic emulsion at a spread rate of 5 sq.m. per liter, using SIKA - Antisol 15 resin base solvent solution compound that complies with ASTM C309 - Type 1 Class B or similar approved.
- Fence to be bolted to concrete with M16 x 125mm long stainless steel anchor bolts.
- All premix at planted posts to be reinstated

4. STEEL PANELS

- All steel, to be hot-dipped galvanised with minimum zinc coating thickness being 105 microns (Heavy Duty Galvanising). (SABS 763)
- All welds 6mm continuous fillet.
- All bolts, washers & nuts to be stainless steel grade AISI 316. Thread projection beyond nut to be damaged once fastened or tack welded as security measure.
- No cutting of steel or welding on site will be allowed without prior approval from the Technical Officer.
- Contractor to calculate all cutting dimension and to produce shop details for approval by the Technical Officer prior to fabrication.

- VOLUMES (Concrete) :
Posts = 0,0675 cub.m. each.

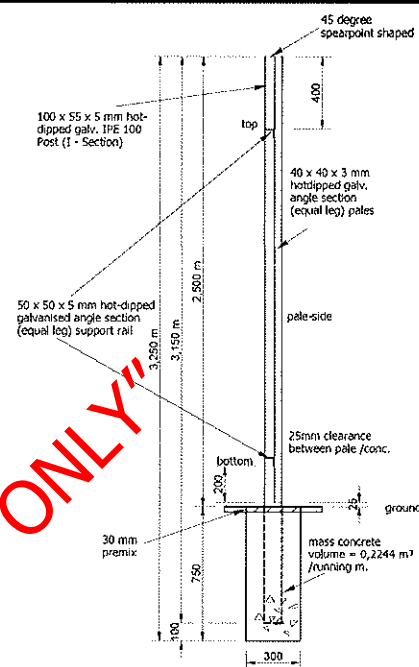

Cross Section 1

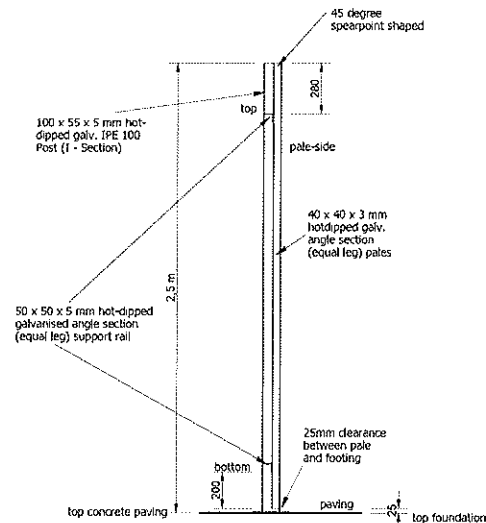

Cross Section 2

Scale = 1 : 20

Notes

- All steel pallisades, posts and other components to be hot dipped galvanised.

Designation	Date	Signature
Port Manager		
Harbour Master		
Financial Manager		
Risk Manager		
Environmental Manager		
Security Manager		
Property Manager		
Corporate Affairs Manager		

No	Amendments	Date	Approved



Port of Port Elizabeth

Car Terminal

Proposed Pallisade fence and gates alterations (September 2010)

Elevation and Cross sections

Project Manager		Port Engineer	
Date	Date		
Designed	D.H.R.	Scale	1 : 20
Drawn	D.H.R.	File	W4/09/009
Checked	W.C.E.	Date	2010-12-29
Amendments	A2	PEH51I0962-02-00	