



Transnet SOC Limited
Transnet RME

REQUEST FOR QUOTATION

TFR RME RFQ Board
 TFR RME RFQ Board
 Transnet Freight Rail - RME
 PROCUREMENT DEPARTMENT

Registration Number: 1990/000900/06
 Vat Number : 4720103177

Attention:
 Telephone Number :
 Fax Number :
 Vendor Number :500000

Quotation Deadline Date : 16.10.2013
Quotation Deadline Time : 16:00

REQUEST for QUOTATION
 Transnet RME
RFQ Number / Date
 6000176965 / 04.10.2013
Contact Person / Telephone
 Troy Stevens / 021 940 1892
Return to VAX Number/EMAIL
 0218100000 / TCPTendersCapeTown@Transnet.net

Item	Material	Description	RFQ Qty	UoM	Required Del date	Confirm Del date	Unit Price Excl	Total Price Excl
00010		Bracket	2,000	ea	31.10.2013			

Bracket
 Clamping bracket tie wire TMFB138 280mm hole CRS330L

Contact person Jeff Niemand 0834556385

Project number 1414792

Delivery address: Bellville Square stores

Requester and Delivery Address:

Richard Carswell - Transnet Freight Rail.(RME)
 Deliver to Bellville Square Bellville South
 Western Cape

Tel: Richard Carswell 0219401813 & 0834556391
 Cell: Jeff Niemand 0834556385

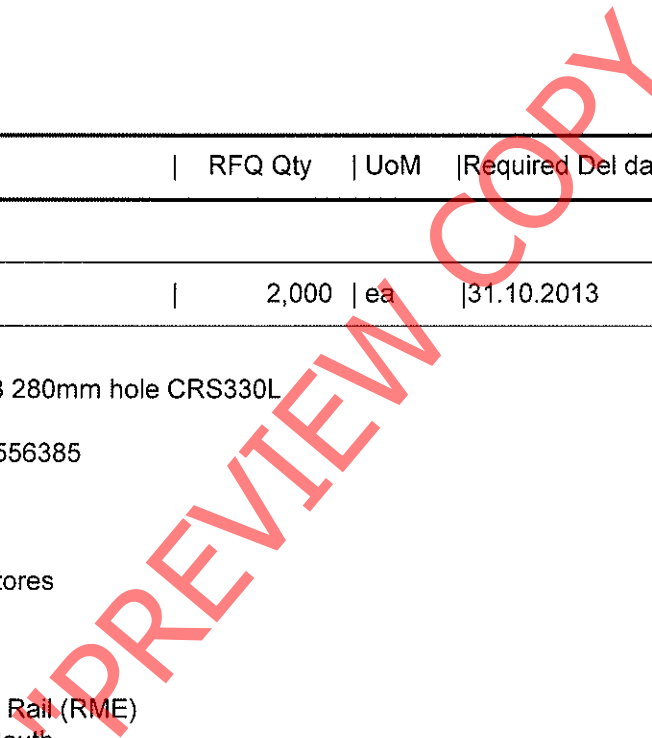



Transnet SOC Limited
 Transnet RME
 TFR RME RFQ Board
 TFR RME RFQ Board
 Transnet Freight Rail - RME
 PROCUREMENT DEPARTMENT
 0000

REQUEST FOR QUOTATION

Registration Number: 1990/000900/06
 Vat Number : 4720103177

Attention:
 Telephone Number :
 Fax Number :
 Vendor Number :500000

Quotation Deadline Date : 16.10.2013
Quotation Deadline Time : 16:00

REQUEST for QUOTATION
 Transnet RME
RFQ Number / Date
 6000176965 / 04.10.2013
Contact Person / Telephone
 Troy Stevens / 021 940 1892
Return to VAX Number/EMAIL
 0218100000 / TCPtendersCapeTown@Transnet.net

Item	Material	Description	RFQ Qty	UoM	Required Del date	Confirm Del date	Unit Price Excl	Total Price Excl
------	----------	-------------	---------	-----	-------------------	------------------	-----------------	------------------

Email: richard.carswell@transnet.net
 Fax: 021 9401938

If you are unable to quote for this enquiry, please submit a NO QUOTE, with a short reason, if possible, for not being able to quote.

Otherwise we look forward to receive your quote by the date and time stated.

00020		Insulator	2,000	ea	31.10.2013			
-------	--	-----------	-------	----	------------	--	--	--

Insulator
 Insulator standoff 25KV tongue/socket TNC-21

Contact person Jeff Niemand 0834556385

Project number 1414792

Delivery address: Bellville Square stores

Requester and Delivery Address:

Richard Carswell - Transnet Freight Rail (RME)

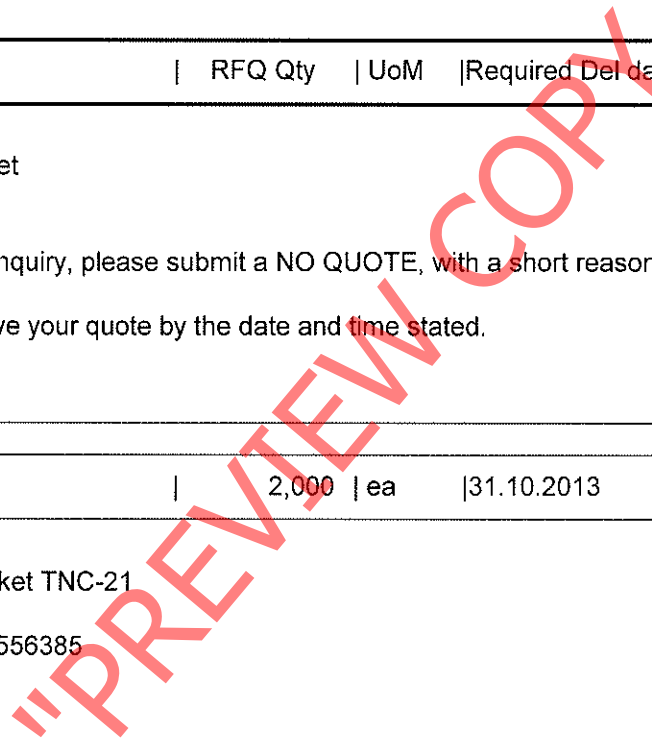



Transnet SOC Limited
Transnet RME
 TFR RME RFQ Board
 TFR RME RFQ Board
 Transnet Freight Rail - RME
 PROCUREMENT DEPARTMENT
 0000

REQUEST FOR QUOTATION

Registration Number: 1990/000900/06
Vat Number : 4720103177

Attention:
 Telephone Number :
 Fax Number :
 Vendor Number : 500000

Quotation Deadline Date : 16.10.2013
Quotation Deadline Time : 16:00

REQUEST for QUOTATION
 Transnet RME
RFQ Number / Date
 6000176965 / 04.10.2013
Contact Person / Telephone
 Troy Stevens / 021 940 1892
Return to VAX Number/EMAIL
 0218100000 / TCPtendersCapeTown@Transnet.net

Item	Material	Description	RFQ Qty	UoM	Required Del date	Confirm Del date	Unit Price Excl	Total Price Excl
------	----------	-------------	---------	-----	-------------------	------------------	-----------------	------------------

Deliver to Bellville Square Bellville South
 Western Cape

Tel: Richard Carswell 0219401813 & 0834556391
 Cell: Jeff Niemand 0834556385
 Email: richard.carswell@transnet.net
 Fax: 021 9401938

If you are unable to quote for this enquiry, please submit a NO QUOTE, with a short reason, if possible, for not being able to quote.

Otherwise we look forward to receive your quote by the date and time stated.

"PREVIEW COPY"

Transnet SOC Limited
 Transnet RME
 TFR RME RFQ Board
 TFR RME RFQ Board
 Transnet Freight Rail - RME
 PROCUREMENT DEPARTMENT
 0000

REQUEST FOR QUOTATION

Registration Number: 1990/000900/06
 Vat Number : 4720103177

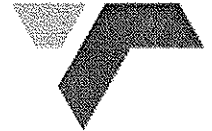
**Attention:**

Telephone Number :
 Fax Number :
 Vendor Number : 500000

Quotation Deadline Date : 16.10.2013
Quotation Deadline Time : 16:00

REQUEST for QUOTATION

Transnet RME
RFQ Number / Date
 6000176965 / 04.10.2013
Contact Person / Telephone
 Troy Stevens / 021 940 1892
Return to VAX Number/EMAIL
 0218100000 / TCPtendersCapeTown@Transnet.net

Delivery Address

TFR RME Cape Town
 De Gatt Complex, Behind Propne
 Bellville South, Cape Tow
 7530

This RFQ is subject to the following conditions:

1. Price/s : The price/s quoted in SA currency and is excluding of V.A.T
2. Delivery : The price/s quoted should include delivery cost to the delivery address stated on the RFQ
3. Returnables : A valid tax clearance certificate and BBBEE certificate from a SANAS accredited verification agency attached to quotation for all quotes above R30 000.
Please note that only the official Transnet RFQ will be accepted and all other correspondence to be attached to the original
4. Safety : To confirm to Transnet Capital Projects Health & Safety plan and specification; HAS-std-0001, copy available on request.
5. Confirmation: To confirm your participation in this tender process please sign and return this document as immediate effect prior to the quotation deadline.
6. Negotiations: The Employer may elect to negotiate the final terms of the contract/order with the preferred tenderer in accordance with Clauses F.2.17 and F.3.13 of the CIDB Standard Conditions of Tender. A copy of which is available upon request.

 Signature

 Date

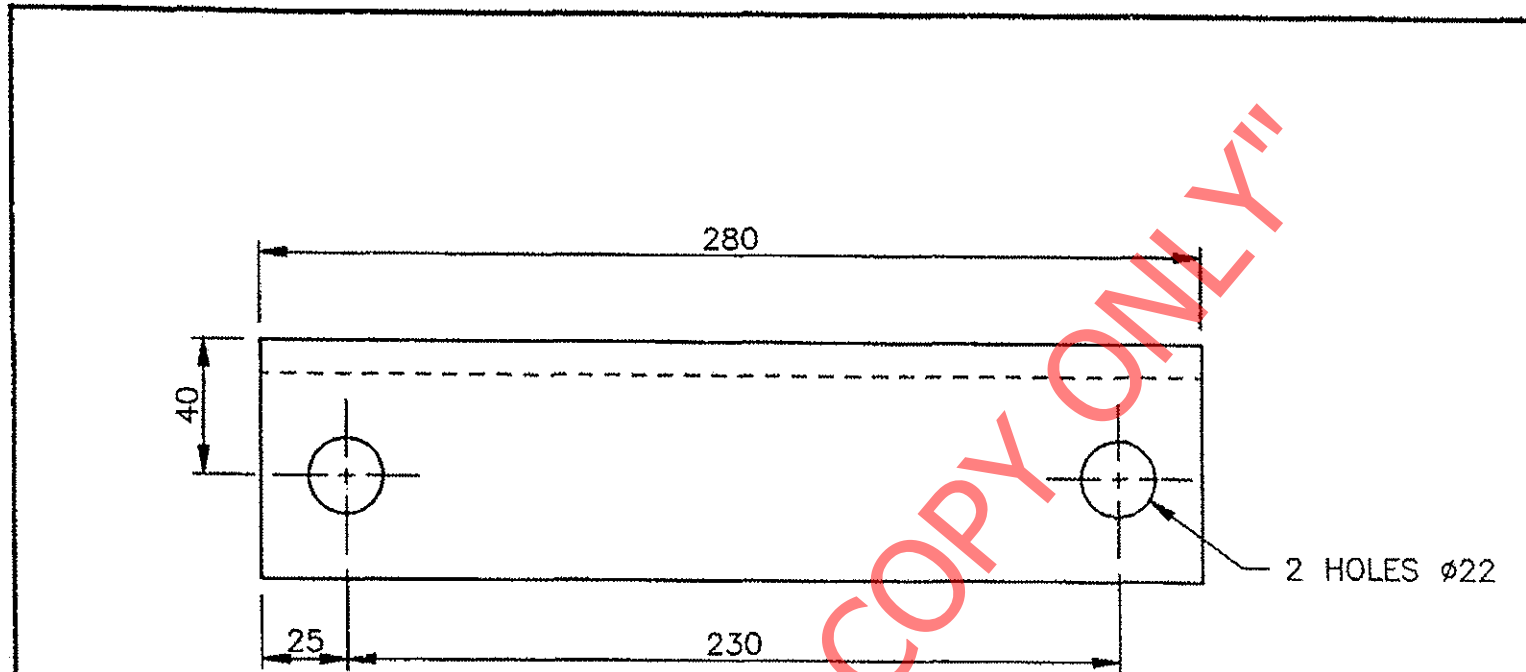

FINISH
ZINC COAT TO SABS 763 FOR CONDITIONS IN SITU
WHEN NOT PART OF WELDING COMPONENT.

AMENDMENTS		
NO	NAME	DATE
1	JVT	95-09-12

DRG REVISED.
PREVIOUS NO. WAS
CEE-TMHA-84.
DO REF: T95/055

MATERIAL: ITEM NO 11/14508, STEEL, ANGLE, 70 x 70 x 10 x 280 LG

DO REF: Y76/43	GEN TOL: LIN± ±1,5	ANG± -
DRN: B v RENSBURG	CKD: W.R.G.	DATE: 78-03-31
ENG: J DE V.	P. PIENAAR for CHIEF ENG	

CLAMPING BRACKET
UNIVERSAL COLUMNS AND CONCRETE MAST

INFRASTRUCTURE
(ELECTRICAL)



DIMENSIONS: mm
SCALE: 1:2



DRG NO CEE-
TMFB-138

SHT - OF -

10000973

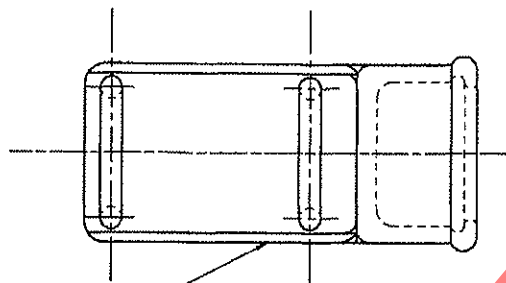
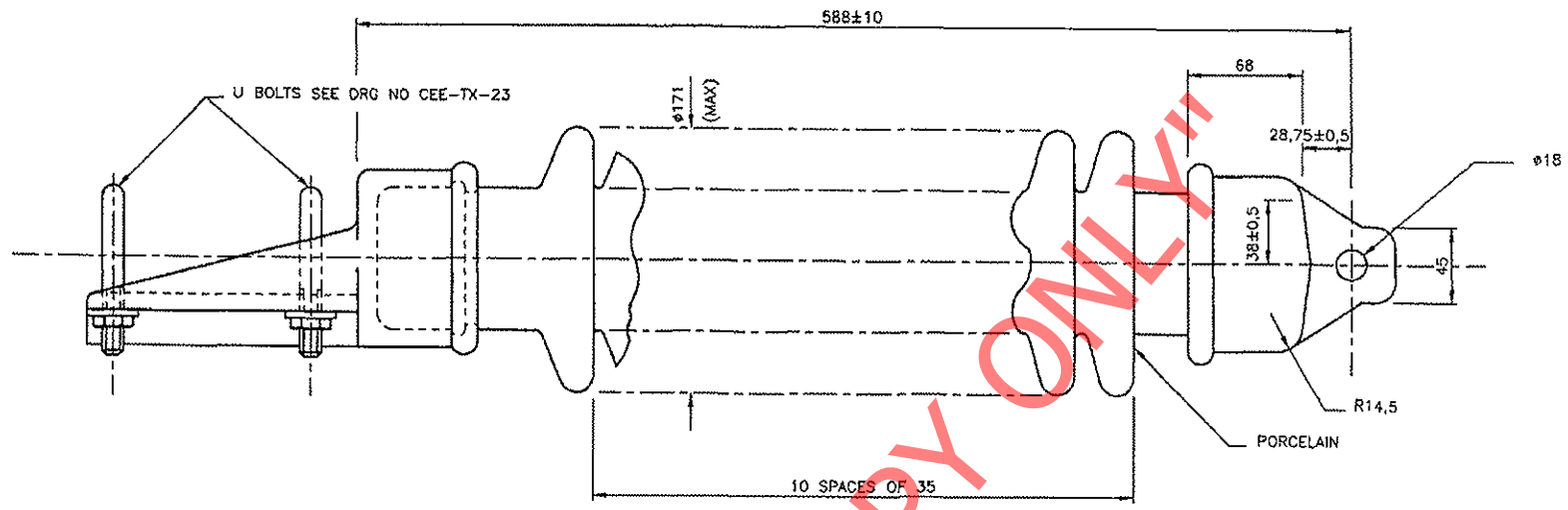

INFORMATION

1. MINIMUM TENSILE BREAKING LOAD:----- 60kN.
2. MINIMUM BENDING STRENGTH:----- 2000Nm.
3. NOMINAL CREEPAGE DISTANCE:-----
4. MINIMUM CREEPAGE DISTANCE:----- 1200mm.
5. ARCING DISTANCE:----- 420mm.(MIN.)
6. LIGHTING IMPULSE WITHSTAND VOLTAGE:----- 250KV.
7. WITHSTAND ALTERNATING VOLTAGE UNDER RAIN:--- 95KV.

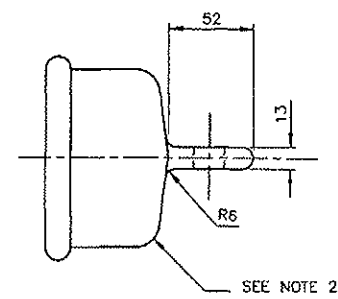

CAP, SOCKET, INSULATOR SEE DRG NO CEE-TN-175

NOTES

1. INSULATOR TO COMPLY WITH SPEC SABS 177.
2. PACKING: EACH INSULATOR SHALL BE PACKED IN A SEPARATE CRATE TO OBIATE BREAKAGE IN TRANSPORT AND STORAGE. EACH CRATE SHALL BE MARKED WITH THE ORDER NUMBER AND MAKERS NAME.

DO REF: T80/85	GEN TOL: LIN± 1	ANG± 2'
DRN: B vd WESTH	GKD: R McMILLAN	DATE: 80-02-11
ENG: _____	GA WILLIAMS	for ASST GEN MAN
CENTRAL DRAWING OFFICE INFRASTRUCTURE (ELECTRICAL)		

25KV AC STAND-OFF INSULATOR
SOLID CORE, TONGUE AND SOCKET



AMENDMENTS		
NO	NAME	DATE
1	JVT	97-04-07

REVISED, DRG NO WAS CEE-TN-162.
DO REF: T96/001

2		
---	--	--

STORES ITEM NUMBER ADDED.
DO REF: CDO/620.

STORES ITEM NO
54/7618
DIMENSIONS: mm
SCALE: 1:2

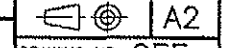

DRAWING NO CEE-
TNC-21

SHEET ____ OF ____

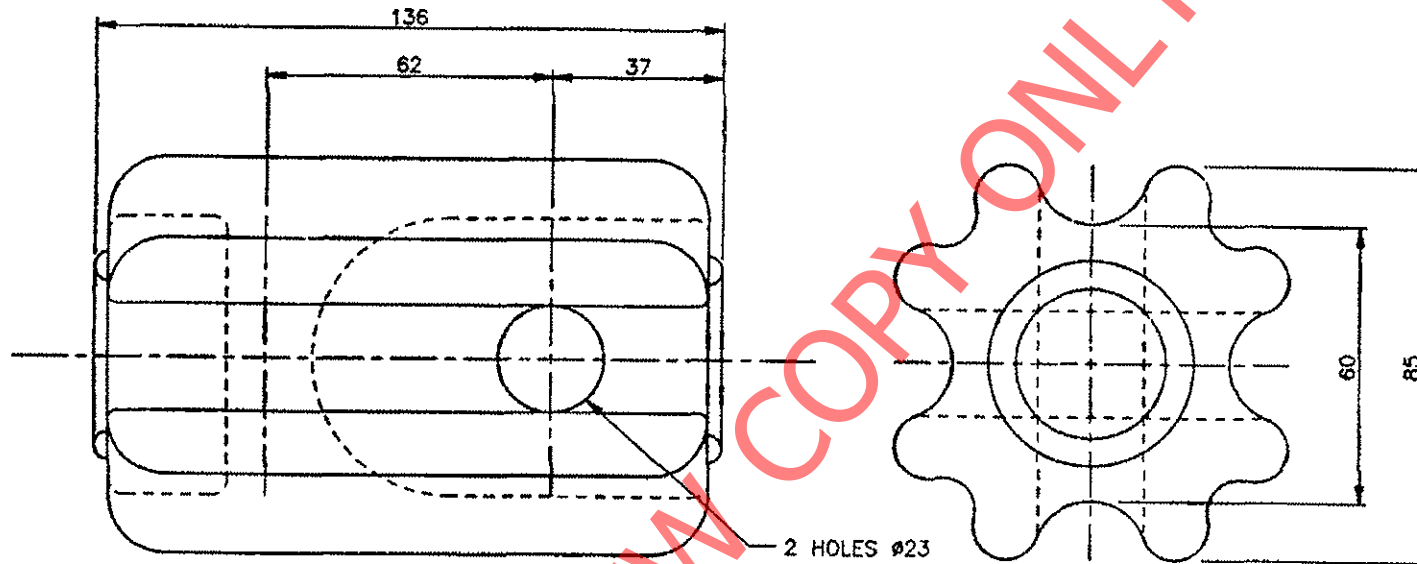

NOTE
INSULATOR TO HAVE PERMANENT MARK TO IDENTIFY

INFORMATION
 DRY FLASH OVER: 35 000V
 WET FLASH OVER: 30 000V
 ULTIMATE TENSILE STRENGTH: 110kN
 FACTOR OF SAFETY: 2,5
 WORKING LOAD: 44kN

AMENDMENTS		
NO	NAME	DATE
1	JVT	97-09-05

REVISED, DRAWING NO
WAS TN-388.
DO REF: T96/021

STORES ITEM NO
54/16254

DIMENSIONS: mm
SCALE: 1:1

A3
 DRAWING NO CEE-
 TNC-22
 SHEET — OF —

MATERIAL: GLAZED PORCELAIN		
DO REF: T1/85/6	GEN TOL: LIN±	ANG± -
DRN: A ÜBERHÜTZER	CKD: A LOTTERING	DATE: 85/11/29
ENG: R.B.	RS MANN	for CHIEF ENG
INFRASTRUCTURE (ELECTRICAL)		SPOORNET

INSULATOR, STRAIN
STAY WIRE ARRANGEMENT

ITEM	DESCRIPTION	QTY	STORES ITEM NO	DRG NO	CEE-	AMENDMENTS	
1	CLEVIS PIN Ø18 WITH LOCKING SPLIT PIN	1	54/4020	TX-66		NO	NAME DATE
2	INSULATOR	1				1	JVT 87-04-07

REVISED, DRG NO WAS CEE-TN-161, DO REF: T96/001

2 ~~XXXXXXXXXX~~ ~~XXXXXXXXXX~~

STORES ITEM NUMBER ADDED. DO REF: CDO/620.

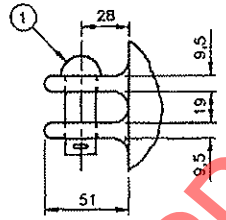
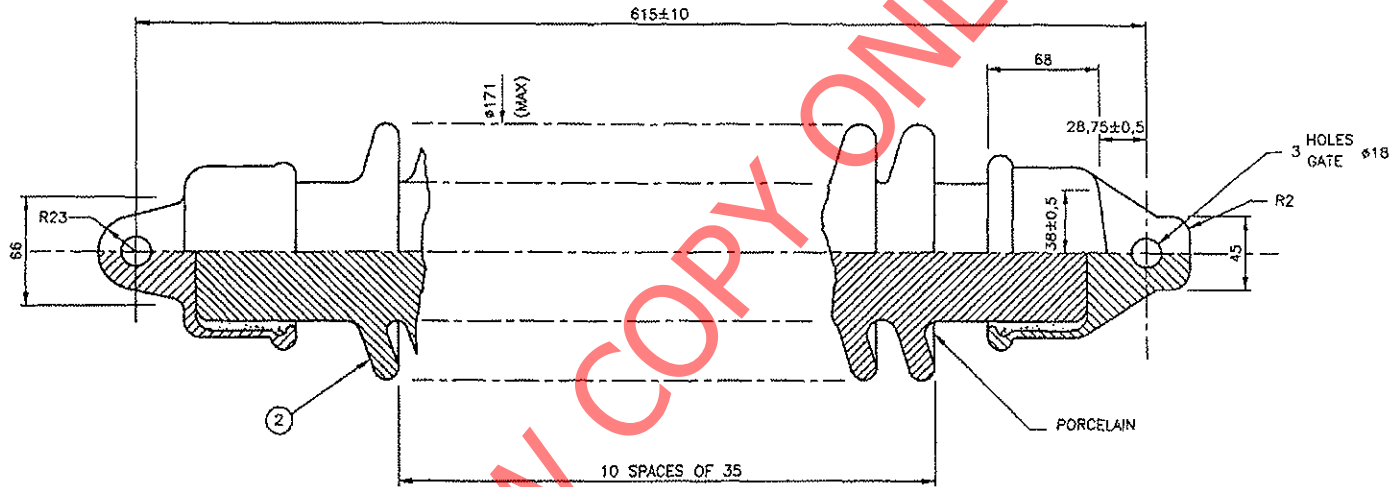

INFORMATION

1. MINIMUM TENSIBLE BREAKING LOAD:----- 60KN.
2. MINIMUM BENDING STRENGTH:----- 2000Nm.
3. NOMINAL CREEPAGE DISTANCE:-----
4. MINIMUM CREEPAGE DISTANCE:----- 1200mm.
5. ARCING DISTANCE:----- 420mm.(MIN.)
6. LIGHTING IMPULSE WITHSTAND VOLTAGE:----- 250KV.
7. WITHSTAND ALTERNATING VOLTAGE UNDER RAIN:----- 95KV.

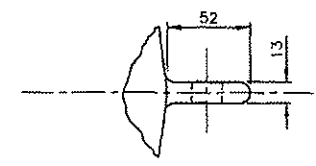

NOTES

1. INSULATOR TO COMPLY WITH SPEC SABS 177.
2. PACKING: EACH INSULATOR SHALL BE PACKED IN A SEPARATE CRATE TO OBIATE BREAKAGE IN TRANSPORT AND STORAGE. EACH CRATE SHALL BE MARKED WITH THE ORDER NUMBER AND MAKERS NAME.

DO REF: T80/65	GEN TOL: LIN± 1	ANG± 2'
DRN: B V RENSBURG	CKD: R McMILLAN	DATE: 80-02-11
ENG: _____	GA WILLIAMS	for ASST GEN MAN
CENTRAL DRAWING OFFICE INFRASTRUCTURE (ELECTRICAL)		

25kv AC TENSION INSULATOR
SOLID CORE, TONGUE AND CLEVIS



STORES ITEM NO 54/11226
DIMENSIONS: mm SCALE: 1:2
A2
DRAWING NO CEE- TNC-20
SHEET ____ OF ____