



Transnet SOC Limited
Transnet RME

REQUEST FOR QUOTATION

TFR Official Tender Board.
TFR Tender Board
Johannesburg.
2000

Registration Number: 1990/000900/06
Vat Number : 4720103177

Attention:
TFR Official Tender Board.
Telephone Number :
Fax Number :
Vendor Number :500000

Quotation Deadline Date : 30.09.2013
Quotation Deadline Time : 12:00

REQUEST for QUOTATION
Transnet RME
RFQ Number / Date
6000175318 / 20.09.2013
Contact Person / Telephone
Eddie Quinn / 035 905 3664
Return to VAX Number/EMAIL
0865159978 / TCPtendersRichardsBay@Transnet.net

Item	Material	Description	RFQ Qty	UoM	Required Del date	Confirm Del date	Unit Price Excl	Total Price Excl
00010		Limit Piece as per Drg.	30	ea	11.10.2013			
Manufacture & Deliver, 30 x HDG Limit Pieces, as per Drawing No: CEE-TND-4, Sheet: 3. Delivered to 1 Morris Road - Empangeni Rail - Old Goods Shed. Contact: Mr Pierre Crocker Tel: 035-905 3638 / 083 279 0437.								
00020		Dropper Clip Catenary	400	ea	11.10.2013			
Manufacture & Deliver, 400 x S/Steel (304) Dropper Clips, for Catenary 80mm square, as per Drawing No: CEE-TND-36. Delivered to 1 Morris Road - Empangeni Rail - Old Goods Shed. Contact: Mr Pierre Crocker Tel: 035-905 3638 / 083 279 0437.								
00030		Guide Piece as per Drg.	30	ea	11.10.2013			

manufacture & Deliver, 30 x HDG Guide Pieces, as per Drawing No: CEE-TND-4, Sheet: 2.



Transnet SOC Limited
Transnet RME
 Company
 TFR Official Tender Board.
 TFR Tender Board
 Johannesburg.
 2000

REQUEST FOR QUOTATION

Registration Number: 1990/000900/06
 Vat Number : 4720103177

Attention:
 TFR Official Tender Board.
 Telephone Number :
 Fax Number :
 Vendor Number :500000

Quotation Deadline Date : 30.09.2013
Quotation Deadline Time : 12:00

REQUEST for QUOTATION
 Transnet RME
RFQ Number / Date
 6000175318 / 20.09.2013
Contact Person / Telephone
 Eddie Quinn / 035 905 3664
Return to VAX Number/EMAIL
 0865159978 / TCPtendersRichardsBay@Transnet.net

Item	Material	Description	RFQ Qty	UoM	Required Del date	Confirm Del date	Unit Price Excl	Total Price Excl
		Delivered to 1 Morris Road - Empangeni Rail - Old Goods Shed. Contact: Mr Pierre Crocker Tel: 035-905 3638 / 083 279 0437.						
00040		Guide Piece as per Drg.	30	ea	11.10.2013			

Manufacture & Deliver, 30 x HDG (Short) Guide Pieces, as per Drawing No: BBB1913.
 Delivered to: 1 Morris Road - Empangeni Rail - Old Goods Shed.
 Contact: Mr Pierre Crocker Tel: 035-905 3638 / 083 279 0437.

Transnet Limited t/a Transnet Freight Rail (R.M.E.) # Richards Bay, hereby invite your company to submit a detailed quotation for:

The Supply, Deliver and Offload of Various OHTE Items, mentioned above, and to Transnet Specifications, delivered to 1 Morris Road, Empangeni Rail, Old Goods Shed.

All technical queries relating to this invitation may be addressed to;
 Mr. Pierre Crocker Tel: 083 279 0437 / 035-905 3638.

All tender related queries pertaining to this invitation may be addressed to;
 Mr. Eddie Quinn, Tel: 035 # 905 3664 / 083 564 6992.

The closing time for receipt of your official quotations is 12:00 hours on Monday, 30 September 2013.



Transnet SOC Limited
Transnet RME
 Company
 TFR Official Tender Board.
 TFR Tender Board
 Johannesburg.
 2000

REQUEST FOR QUOTATION

Registration Number: 1990/000900/06
Vat Number : 4720103177

Attention:
 TFR Official Tender Board.
 Telephone Number :
 Fax Number :
 Vendor Number :500000

Quotation Deadline Date : 30.09.2013
Quotation Deadline Time : 12:00

REQUEST for QUOTATION
 Transnet RME
RFQ Number / Date
 6000175318 / 20.09.2013
Contact Person / Telephone
 Eddie Quinn / 035 905 3664
Return to VAX Number/EMAIL
 0865159978 / TCPtendersRichardsBay@Transnet.net

Item	Material	Description	RFQ Qty	UoM	Required Del date	Confirm Del date	Unit Price Excl	Total Price Excl
------	----------	-------------	---------	-----	-------------------	------------------	-----------------	------------------

Telephonic and late quotes will not be accepted.
 All quotations should be clearly marked, and forwarded to:
 Me Yogeshnie Gengan, Tender & Fax Assistant,
 Fax No: 086 515 9978 and / or
 e-mailed to: TCPtendersRichardsBay@transnet.net

The contractor / supplier's address and identification details have to be clearly shown on each quotation submitted.

Please supply the following documents with your quotation;

- Valid Tax Clearance certificate.
- Copy of your latest B.B.B.E.E. Certificate.
- Certificate of good standing with the Workman's Compensation Commissioner.

Failing to submit any of the documents mentioned above, could result in your quotation to be disqualified / not accepted.

Note: #Transnet may not necessarily accept the lowest or any other offer and reserves the right to select in its favor any or, a portion of any offer made"

If you are unable to quote for this RFQ, please submit a NO QUOTE, with a short reasons, if possible, for not being able to quote.

Otherwise we look forward to receive your detailed quote by the date and time stated.



Transnet SOC Limited
Transnet RME
 Company
 TFR Official Tender Board,
 TFR Tender Board
 Johannesburg.
 2000

REQUEST FOR QUOTATION

Registration Number: 1990/000900/06
 Vat Number : 4720103177

Attention:
 TFR Official Tender Board.
 Telephone Number :
 Fax Number :
 Vendor Number :500000

Quotation Deadline Date : 30.09.2013
Quotation Deadline Time : 12:00

REQUEST for QUOTATION
 Transnet RME
RFQ Number / Date
 6000175318 / 20.09.2013
Contact Person / Telephone
 Eddie Quinn / 035 905 3664
Return to VAX Number/EMAIL
 0865159978 / TCPtendersRichardsBay@Transnet.net

Item	Material	Description	RFQ Qty	UoM	Required Del date	Confirm Del date	Unit Price Excl	Total Price Excl
------	----------	-------------	---------	-----	-------------------	------------------	-----------------	------------------

Yours faithfully,

Delivery Address

TFR RME Richards Bay
 Old Naval Base, Commodores Clo
 Meerensee, Richards Bay
 3900

This RFQ is subject to the following conditions:

1. Price/s : The price/s quoted in SA currency and is excluding of V.A.T
2. Delivery : The price/s quoted should include delivery cost to the delivery address stated on the RFQ
3. Returnables : A valid tax clearance certificate and BBBEE certificate from a SANAS accredited verification agency attached to quotation for all quotes above R30 000.
Please note that only the official Transnet RFQ will be accepted and all other correspondence to be attached to the original
4. Safety : To confirm to Transnet Capital Projects Health & Safety plan and specification; HAS-std-0001, copy available on request.
5. Confirmation: To confirm your participation in this tender process please sign and return this document as immediate effect prior to the quotation deadline.
6. Negotiations: The Employer may elect to negotiate the final terms of the contract/order with the preferred tenderer in accordance with Clauses F.2.17 and F.3.13 of the CIDB Standard Conditions of Tender. A copy of which is available upon request.

Signature

Date

Req: 10343210.

AMENDMENTS		
NO	NAME	DATE
1	<i>[Signature]</i>	11/04/2001

TITLE REVISED.
DO REF: CDO/1159

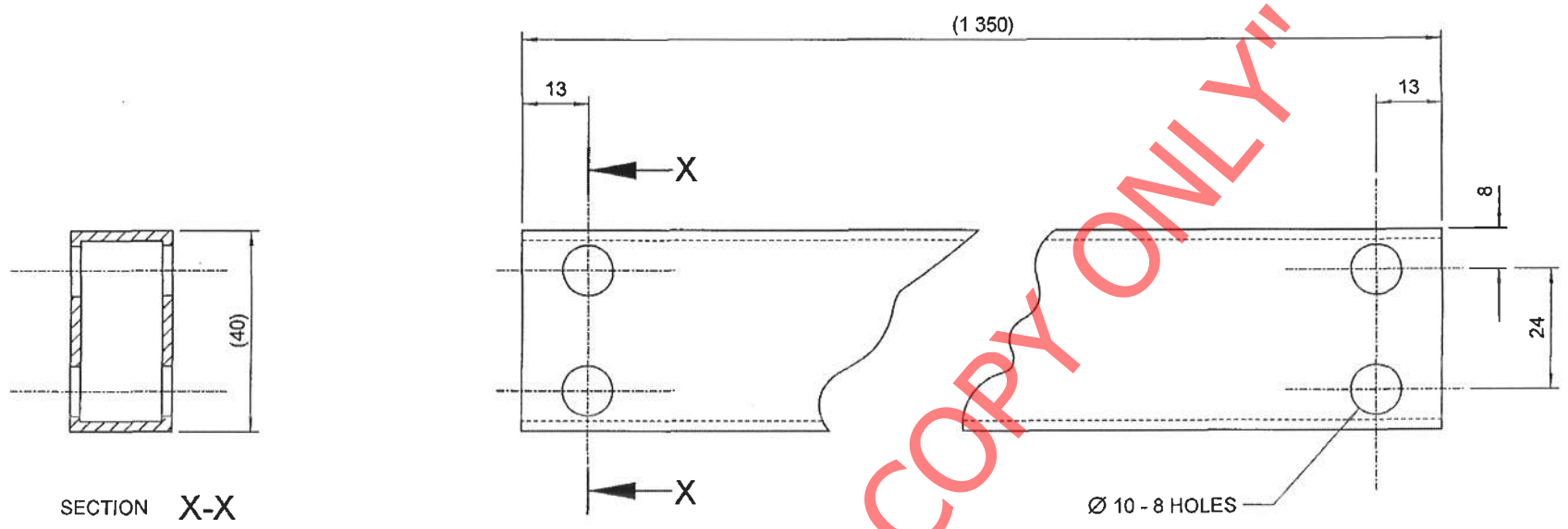

FINISH:
ZINC COAT TO SABS 763

"PREVIEW COPY ONLY"

STORES ITEM NO
DIMENSIONS:mm
SCALE: 1:1

MATERIAL: ITEM NO (11/) STEEL, RECTANGULAR TUBE, 40 x 20 x 2THK x 1 350LG TO SPEC BS 6323

DO REF: T89/23	GEN TOL: LIN ± 0,5	ANG ±
DRN: L E WOOD	CKD: H v VUUREN	DATE: 94 - 03 - 03
ENG: W BRIGHT	W BRIGHT	for CHIEF ENG

LIMIT PIECE
FOR UPLIFT LIMITING DEVICE
3KV DC AND 25KV AC AUTO TENSIONED CONSTRUCTION

CENTRAL DRAWING OFFICE SPOORNET

	A3
DRAWING NO	CEE-
	TND - 4
SHEET	3 OF 3

REQ: 10343627

AMENDMENTS

NO	NAME	DATE
1		19/04/2001

TITLE REVISED.
DO REF: CDO/1159

STORES ITEM NO

DIMENSIONS:mm
SCALE 1:1

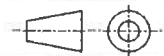

A3

DRAWING NO CEE-
TND - 4
SHEET 2 OF 3

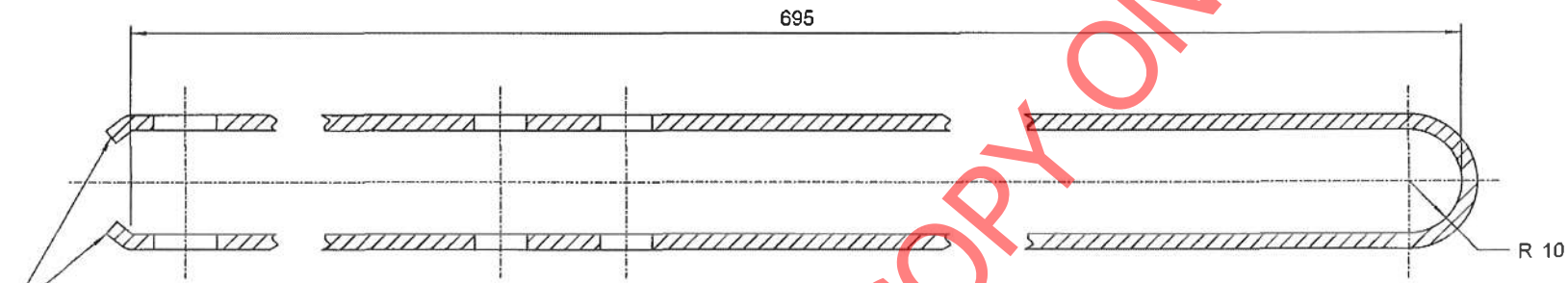
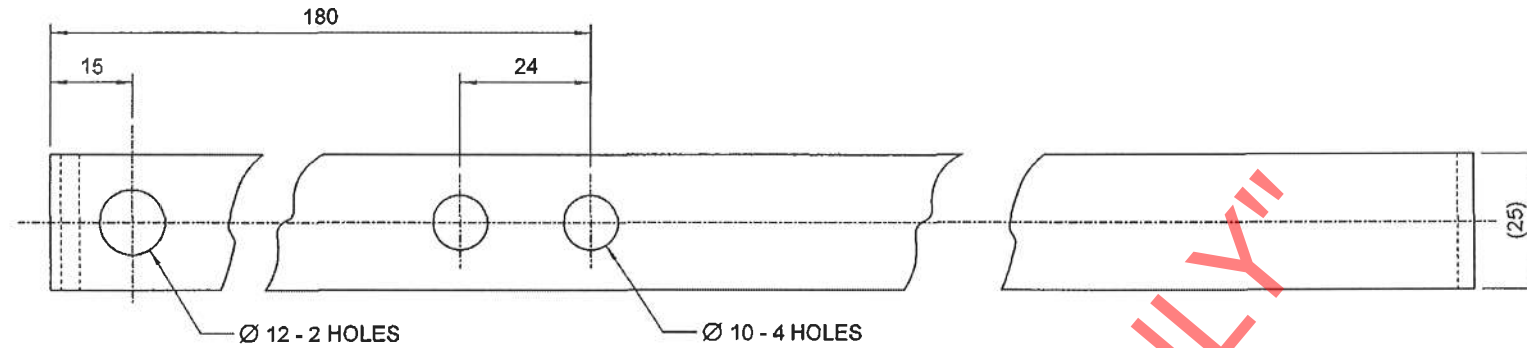

SEE DETAIL - A

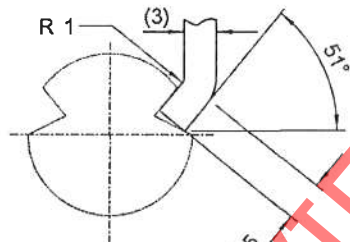

DETAIL - A
SCALE 2:1

FINISH
ZINC COAT TO SABS 763

MATERIAL: ITEM NO (11/) SHEET, STEEL, 25 x 3 x 1 415LG

DO REF: T89/23 GEN TOL: LIN ± 1 ANG ± 1°

DRN: L E WOOD CKD: H v VUUREN DATE: 94 - 03 - 03

ENG: W BRIGHT W BRIGHT for CHIEF ENG

CENTRAL DRAWING OFFICE



GUIDE PIECE

FOR UPLIFT LIMITING DEVICE

3KV DC AND 25KV AC AUTO TENSIONED CONSTRUCTION

REQ: 10343628

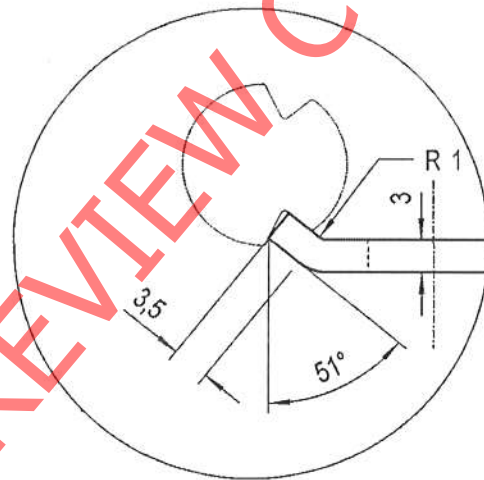
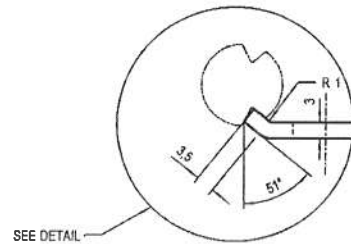
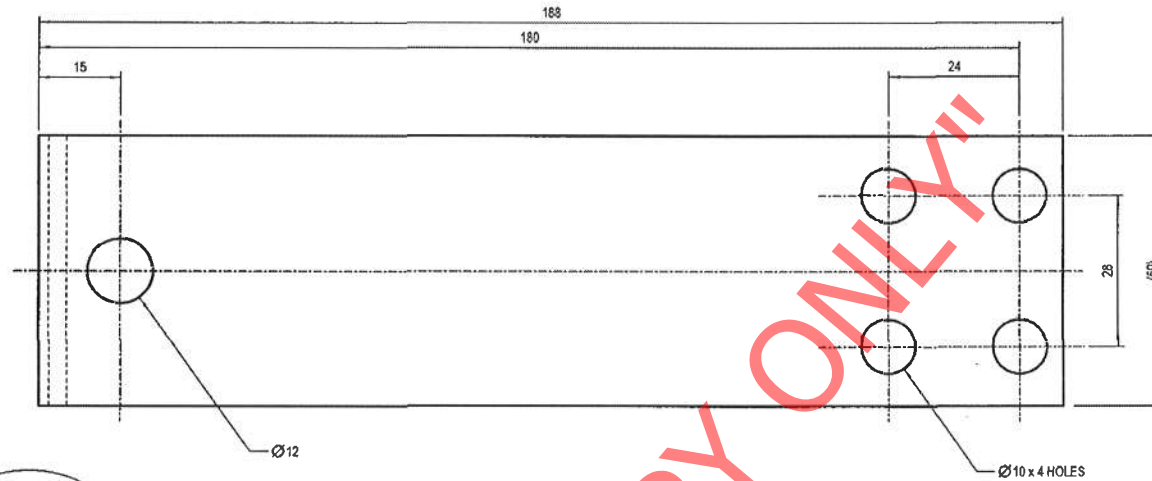

DETAIL
SCALE 2:1

FINISH:
ZINC COAT TO SABS 783 FOR CONDITIONS IN SITU.

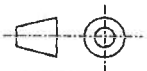

© COPYRIGHT PROTECTED

DIMENSIONS : mm
 TOLERANCE : LIN ± 1 ANG ± 1°
 MATERIAL : SHEET, STEEL, 50 x 3 x 188LG.
 CP REF : -
 VERSION INFO : -

SCALE : 1:1

CDO REF : CDO/ 1159
 DRAWN : JR Anthony
 DESIGNED : WF Mans
 CHECKED : JD van Dyk

DATE: 19/04/2001

APPROVED
 AUTHORIZED

CENTRAL DRAWING OFFICE

GUIDE PIECE (SHORT) FOR UPLIFT LIMITING DEVICE
 3kV DC AND 25kV AC AUTO TENSIONED CONSTRUCTION

SPOORNET

BBB1913
 VERSION 1