



Transnet SOC Limited
Transnet RME

REQUEST FOR QUOTATION

TFR RME RFQ BOARD
XXXXXXXXXXXXXXXXXX
XXXXXXXXXXXXXXXXXX
0000

Registration Number: 1990/000900/06
Vat Number : 4720103177

Attention:
TFR RME RFQ BOARD
Telephone Number :
Fax Number :
Vendor Number :500000

Quotation Deadline Date : 17.09.2013
Quotation Deadline Time : 16H00

REQUEST for QUOTATION
Transnet RME
RFQ Number / Date
6000173689 / 09.09.2013
Contact Person / Telephone
Anne Monge / 031 361 1759
Return to FAX Number/EMAIL
031830000 / TCPtendersDurban@Transnet.net

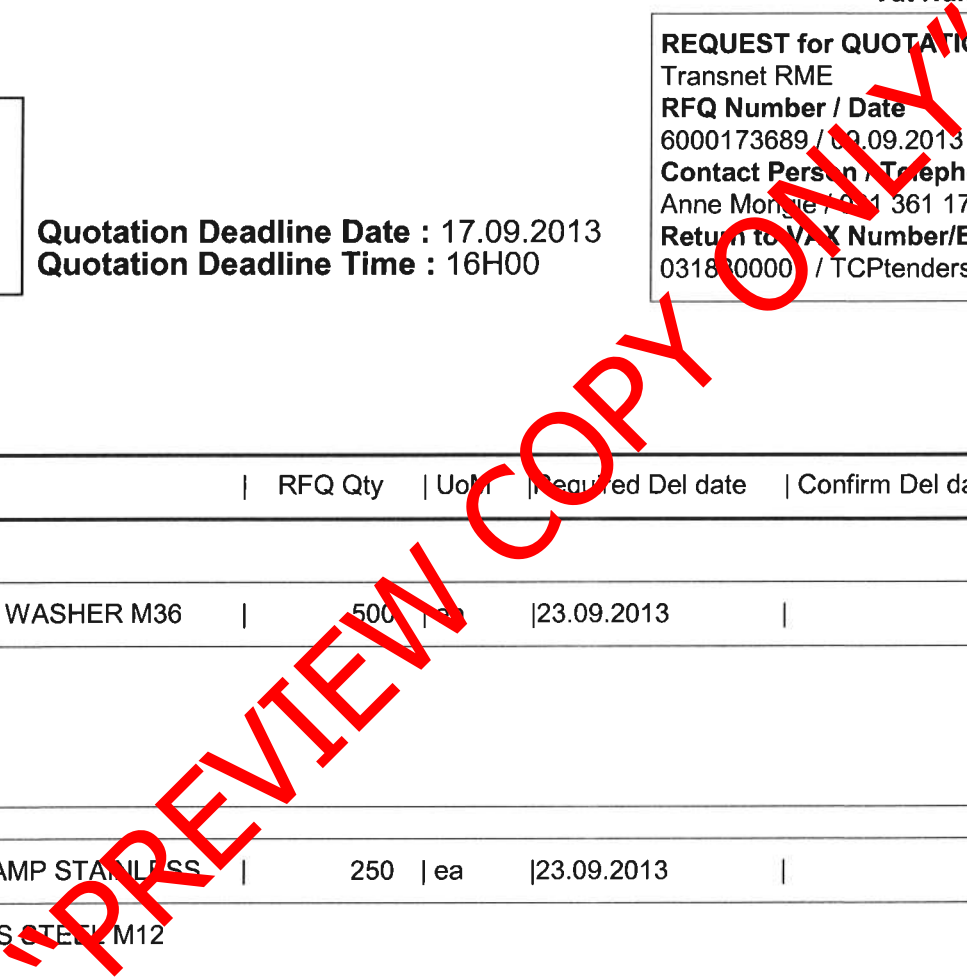

Item	Material	Description	RFQ Qty	UoM	Required Del date	Confirm Del date	Unit Price Excl	Total Price Excl
00010		INSULATING WASHER M36 (CEE-TU-143 SHT 3)	500	ea	23.09.2013			
00020		CROSBY CLAMP STAINLESS STEEL M12	250	ea	23.09.2013			
00030		THIMBLE 14MM/80SQ WIRE S/STEEL 304 (CEE-TNB-85)	150	ea	23.09.2013			



Transnet SOC Limited
 Transnet RME
 TFR RME RFQ BOARD
 XXXXXXXXXXXXXXXX
 XXXXXXXXXXXXXXXX
 0000

REQUEST FOR QUOTATION

Registration Number: 1990/000900/06
 Vat Number : 4720103177

YOUR VAT NUMBER WITH US:

Attention:
 TFR RME RFQ BOARD
 Telephone Number :
 Fax Number :
 Vendor Number :500000

Quotation Deadline Date : 17.09.2013
Quotation Deadline Time : 16H00

REQUEST for QUOTATION
 Transnet RME
RFQ Number / Date
 6000173689 / 03.09.2013
Contact Person / Telephone
 Anne Mongie / 031 361 1759
Return to FAX Number/EMAIL
 0318300001 / TCPtendersDurban@Transnet.net

Item	Material	Description	RFQ Qty	UoM	Required Del date	Confirm Del date	Unit Price Excl	Total Price Excl
00040		CLEVIS PIN 16MM DIAx60M	1,000	ea	13.09.2013			

CLEVIS PIN 16MM DIAx60MM & SPLIT PIN S/STEEL (CEE-TX-066 STAINLESS)

FOR MORE INFORMATION
 PLEASE CONTACT DEES
 (0832789364)

QUOTES MUST BE SENT TO TCPtendersDurban@transnet.net
 YOU MAY ALSO MAIL mduduzi.khoza@transnet.net or fax
 to 0318300001

PLEASE ATTACH COPIES OF BBEE AND TAX CLEARANCE CERTIFICATES TO YOUR QUOTES.

QUOTES WILL CLOSE AT 16H00 ON TUESDAY 17 SEPTEMBER 2013.

PREVIEW COPY



REQUEST FOR QUOTATION

Transnet SOC Limited
Transnet RME
TFR RME RFQ BOARD
XXXXXXXXXXXXXXXXXX
XXXXXXXXXXXXXXXXXX
0000
YOUR VAT NUMBER WITH US:

Registration Number: 1990/000900/06
Vat Number : 4720103177

Attention:
TFR RME RFQ BOARD
Telephone Number :
Fax Number :
Vendor Number :500000

Quotation Deadline Date : 17.09.2013
Quotation Deadline Time : 16H00

REQUEST for QUOTATION
Transnet RME
RFQ Number / Date
6000173689 / 09.09.2013
Contact Person / Telephone
Anne Monge / 031 361 1759
Return to FAX Number/EMAIL
031830000 / TCPtendersDurban@Transnet.net

Delivery Address
TFR RME Durban
100 Eel Road
Bayhead, Durban
4001

This RFQ is subject to the following conditions:

1. Price/s : The price/s quoted in SA currency and is excluding of V.A.T.
2. Delivery : The price/s quoted should include delivery cost to the delivery address stated on the RFQ
3. Returnables : A valid tax clearance certificate and BBBEE certificate from a SANAS accredited verification agency attached to quotation for all quotes above R30 000.
Please note that only the official Transnet RFQ will be accepted and all other correspondence to be attached to the original
4. Safety : To confirm to Transnet Capital Projects Health & Safety plan and specification; HAS-std-0001, copy available on request.
5. Confirmation: To confirm your participation in this tender process please sign and return this document as immediate effect prior to the quotation deadline.
6. Negotiations: The Employer may elect to negotiate the final terms of the contract/order with the preferred tenderer in accordance with Clauses F.2.17 and F.3.13 of the CIDB Standard Conditions of Tender. A copy of which is available upon request.

Signature

Date

"PREVIEW COPY ONLY"

10340420

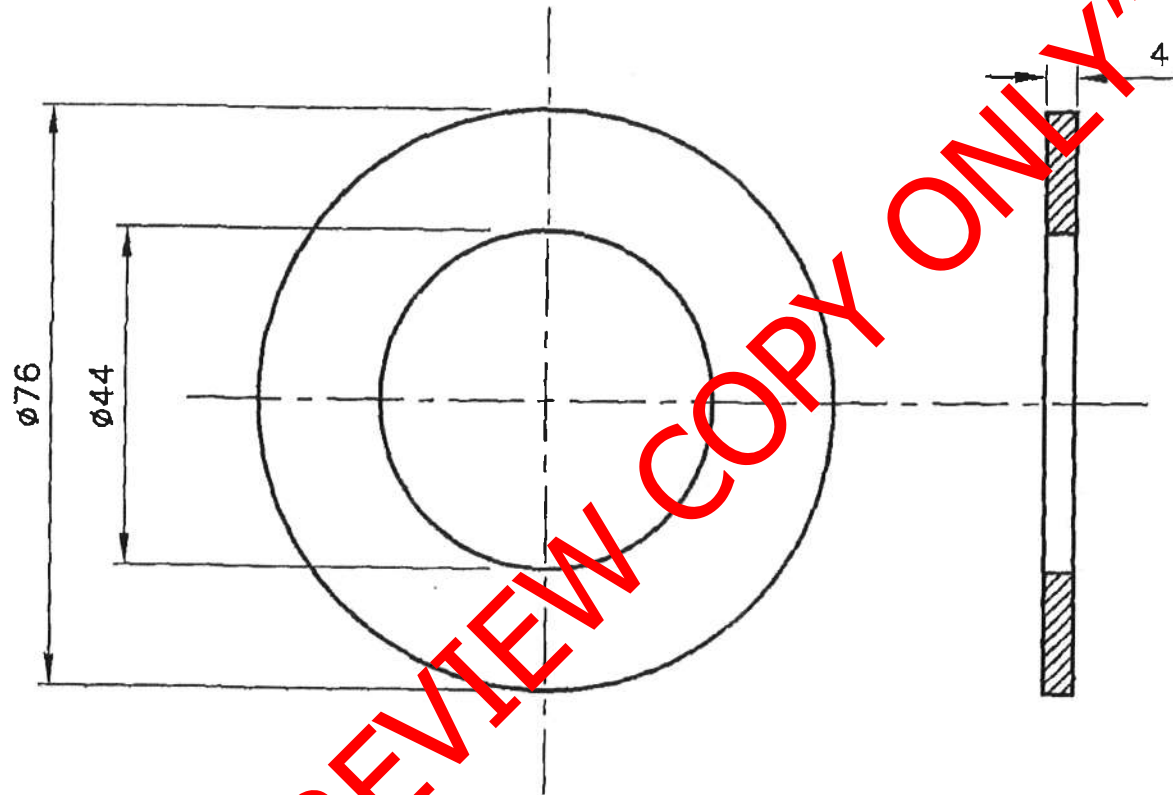

NOTE
THIS DRAWING TO BE READ IN CONJUNCTION WITH SPECIFICATION CEE.0166.

MATERIAL: SYNTHETIC RESIN BONDED GLASS-FIBRE FABRIC (WOVEN) TO SPEC BS 3396 OR EQUAL AND APPROVED

DO REF: T94/031	GEN TOL: LIN ± 0,5	ANG ± —
DRN: C de Koker	CKD: JVT	DATE: 94-07-06
ENG: F SLIER	L O BORCHARD for CHIEF ENG	

CENTRAL DRAWING OFFICE
INFRASTRUCTURE (ELECTRICAL)  SPOORNET

INSULATING WASHER

MAST BASE ANTI-ELECTROLYSIS ARRANGEMENT
4 OR 6 x M36 BOLT GROUP UC MASTS

AMENDMENTS

NO	NAME	DATE
1	JVT	95-04-13

SPECIFICATION IN
NOTE WAS CEE-
13B-4.
DO REF: G95/008.

2		16/11/2000
---	---	------------

STORES ITEM NO
ADDED,
DO REF: CDO/977

STORES ITEM NO.
54/414

DIMENSIONS: mm
SCALE: 1:1



DRG NO CEE-
TU-143
SHT 3 OF 4

103404422

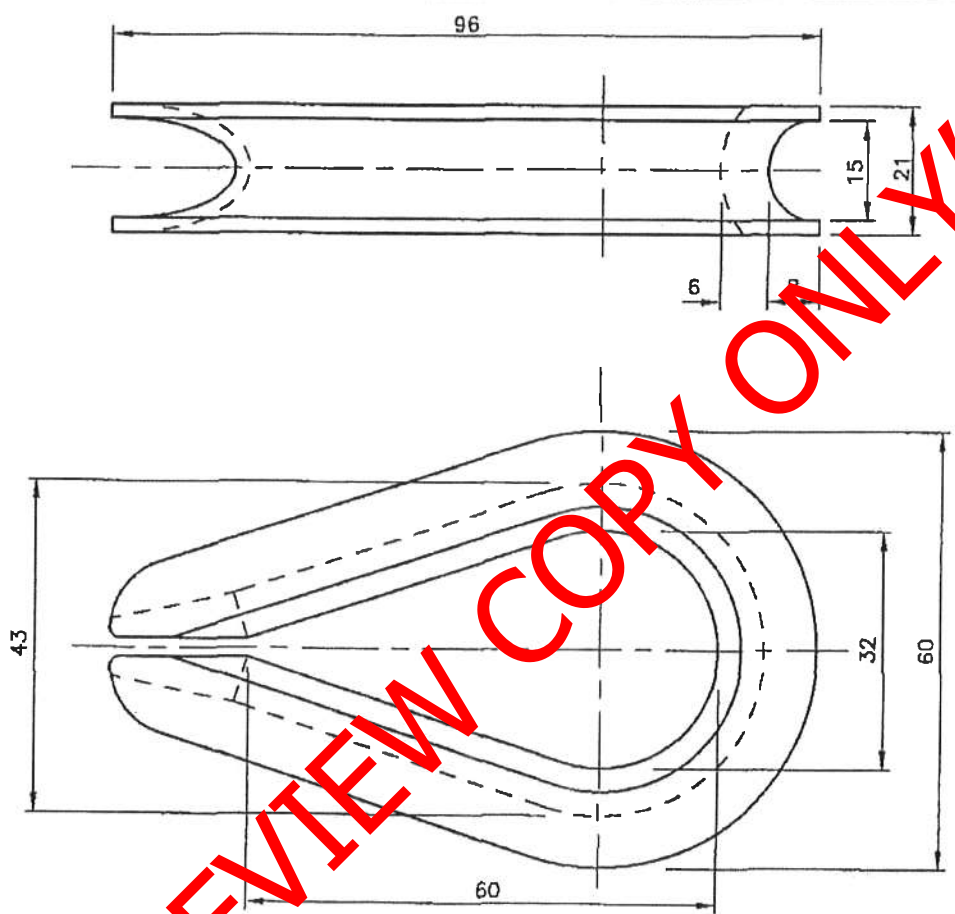

"PREVIEW COPY ONLY"

FINISH

ZINC COAT TO SABS 763 FOR CONDITIONS IN SITU.

AMENDMENTS		
NO	NAME	DATE
1	JVT	2000-10-30

REVISED, DRG NO WAS CEE-TN-292.
DO REF: T96/001

STORES ITEM NO.
54/5264

DIMENSIONS: mm
SCALE: NTS



MATERIAL: ITEM NO 11/ ———, STEEL SEE SPEC SABS 811

DO REF: J27/68	GEN TOL: LIN± 0,5	ANG± 1°
DRN: L N	CKD: E F J	DATE: 68-03-27
ENG: D McKAY	W PHILLIPS for CHIEF ENG	

ROPE THIMBLE

WIRE SIZE - 100mm²

CENTRAL DRAWING OFFICE  SPOORNET

DRG NO CEE-
TNB-85
SHT — OF —

10340423

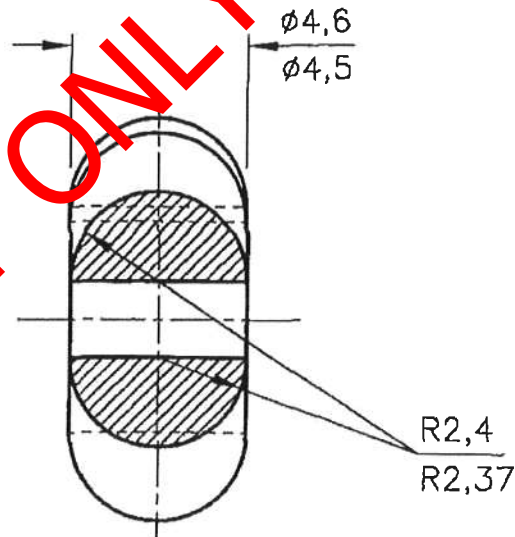
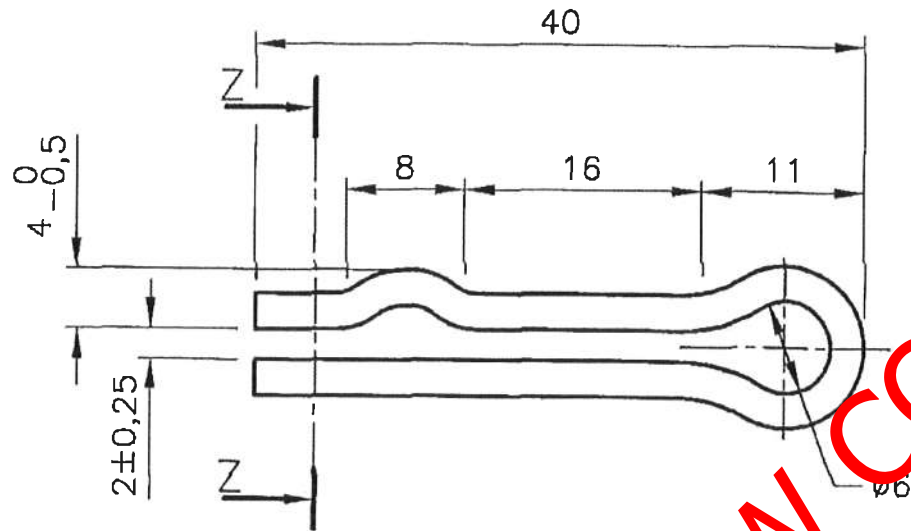

SECTION Z - Z

SCALE 5:1

"PREVIEW COPY ONLY"

AMENDMENTS

NO	NAME	DATE
2	J v DÿK	94-8-4

DRG REVISED.
DO REF T94/046

3	J HARCUS	98-6-25
---	----------	---------

PIN DIAMETER WAS
ø4,8/ø4,74
DO REF: T98/028

STORES ITEM NO.
54/3734

DIMENSIONS: mm
SCALE: 2:1

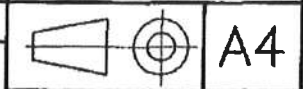

DRG NO CEE-
TX-54
SHT — OF —

MATERIAL: ITEM NO —, BRASS TO SPEC BS 2873/CZ 108 OR STAINLESS STEEL TO SPEC BS 970 GRADE 316S16

DO REF: N37/69 GEN TOL: LIN± 0,5 ANG± —

DRN: C.J.S. CKD: R.N. DATE: 69-03-03

ENG: F PIENAAR F PIENAAR for CHIEF ENG

COTTER PIN

INFRASTRUCTURE
(ELECTRICAL)



T0000640