



Transnet SOC Limited
T/A Transnet Capital Projects

REQUEST FOR QUOTATION

TFR Tender Board - JHB.
 TFR Tender Board.
 Johannesburg.
 2000

Registration Number: 1990/000900/06
Vat Number : 4720103177

Attention:
 TFR Official Tender Board.
 Telephone Number :
 Fax Number :
 Vendor Number :500000

Quotation Deadline Date : 20.08.2013
Quotation Deadline Time : 12:00

REQUEST for QUOTATION
 Transnet Capital Projects
RFQ Number / Date
 6000170533 / 13.08.2013
Contact Person / Telephone
 Eddie Quinn / 035 905 3664
Return to VAX Number/EMAIL
 0865159978 / TCPtendersRichardsBay@Transnet.net

"PREVIEW COPY ONLY"

Item	Material	Description	RFQ Qty	UoM	Required Del date	Confirm Del date	Unit Price Excl	Total Price Excl
00010		Stay Bolt as per Drg.CE	4	ea	30.08.2013			
		Stay Bolt as per Drg. CEE - TNE 31 Sht 2						
00020		Extention Strap as per D	4	ea	30.08.2013			
		Extention Strap as per Drg. CEE - TNE - 1						
00030		Push Pull Off Tube as p	12	ea	30.08.2013			
		Push Pull Off Tube as per Drg. CEE -TND -38						
00040		Steady Arm Attachment w	12	ea	30.08.2013			



Transnet SOC Limited
T/A Transnet Capital Projects
 Company
 TFR Tender Board - JHB.
 TFR Tender Board.
 Johannesburg.
 2000

REQUEST FOR QUOTATION

Registration Number: 1990/000900/06
Vat Number : 4720103177

Attention:
 TFR Official Tender Board.
 Telephone Number :
 Fax Number :
 Vendor Number :500000

Quotation Deadline Date : 20.08.2013
Quotation Deadline Time : 12:00

REQUEST for QUOTATION
 Transnet Capital Projects
RFQ Number / Date
 6000170533 / 13.08.2013
Contact Person / Telephone
 Eddie Quinn / 035 905 3664
Return to VAX Number/EMAIL
 0865169978 / TCPtendersRichardsBay@Transnet.net

"PREVIEW COPY ONLY"

Item	Material	Description	RFQ Qty	UoM	Required Del date	Confirm Del date	Unit Price Excl	Total Price Excl
		Steady Arm Attachment with Locking Bracket.Dimension "A" 1000mm as per Drg. CEE - TMFB - 67.						
00050		Platform Switch Mountin	2	ea	30.08.2013			
		Platform Switch Mounting as per Drg. CEE - TMF -351						
00060		Clamping Bracket as pe	3	ea	30.08.2013			
		Clamping Bracket as per Drg. CEE -TMC - 103						
00070		Operating Handle Mounti	2	ea	30.08.2013			
		Operating Handle Mounting as per Drg.CEE-TMFB-69						
00080		Bracket Clamping as per	4	ea	30.08.2013			



Transnet SOC Limited
 T/A Transnet Capital Projects
 Company
 TFR Tender Board - JHB.
 TFR Tender Board.
 Johannesburg.
 2000

REQUEST FOR QUOTATION

Registration Number: 1990/000900/06
 Vat Number : 4720103177

Attention:
 TFR Official Tender Board.
 Telephone Number :
 Fax Number :
 Vendor Number :500000

Quotation Deadline Date : 20.08.2013
Quotation Deadline Time : 12:00

REQUEST for QUOTATION
 Transnet Capital Projects
RFQ Number / Date
 6000170533 / 13.08.2013
Contact Person / Telephone
 Eddie Quinn / 035 905 3664
Return to VAX Number/EMAIL
 0865159978 / TCPtendersRichardsBay@Transnet.net

Item	Material	Description	RFQ Qty	UoM	Required Del date	Confirm Del date	Unit Price Excl	Total Price Excl
		Bracket Clamping as per Drg. CEE - TMFB - 55						
00090		Attachment Stay Wire as	2	ea	30.08.2013			
		Attachment Stay Wire as per Drg. CEE -TMFB -58						
00100		Hook,Foundation,Staywir	2	ea	30.08.2013			
		Hook,Foundation,Staywire as per Drg. CEE-TQ -53						
00110		AnchorFitting as per Dr	2	ea	30.08.2013			
		Anchor Fitting as per Drg. CEE - TMFB - 59						
00120		Steady Arm ,Hockey Stic	23	ea	30.08.2013			

"PREVIEW COPY ONLY"



Transnet SOC Limited
T/A Transnet Capital Projects
 Company
 TFR Tender Board - JHB.
 TFR Tender Board.
 Johannesburg.
 2000

REQUEST FOR QUOTATION

Registration Number: 1990/000900/06
Vat Number : 4720103177

Attention:
 TFR Official Tender Board.
 Telephone Number :
 Fax Number :
 Vendor Number :500000

Quotation Deadline Date : 20.08.2013
Quotation Deadline Time : 12:00

REQUEST for QUOTATION
 Transnet Capital Projects
RFQ Number / Date
 6000170533 / 13.08.2013
Contact Person / Telephone
 Eddie Quinn / 035 905 3664
Return to VAX Number/EMAIL
 0865159978 / TCPtendersRichardsBay@Transnet.net

"PREVIEW COPY ONLY"

Item	Material	Description	RFQ Qty	UoM	Required Del date	Confirm Del date	Unit Price Excl	Total Price Excl
		Steady Arm ,Hockey Stick Att.3,2m Mast to Rail.Dimension "A" 1100mm as per Drg. CEE -TMFB -124						
00130		Tubalar Cantilever 3,2m	32	ea	30.08.2013			
		Tubalar Cantilever 3,2m Mast to Rail.Dimension "A" 3250mm as per Drg.CEE -TMC -42						
00140		Tie Bar Bracket as per	32	ea	30.08.2013			
		Tie Bar Bracket as per Drg. CEE- TMF -206						
00150		Clamping Bracket Earth	32	ea	30.08.2013			
		Clamping Bracket Earth Wire Cleat as per Drg. CEE -TMFB -168						



Transnet SOC Limited
T/A Transnet Capital Projects
 Company
 TFR Tender Board - JHB.
 TFR Tender Board.
 Johannesburg.
 2000

REQUEST FOR QUOTATION

Registration Number: 1990/000900/06
Vat Number : 4720103177

Attention:
 TFR Official Tender Board.
 Telephone Number :
 Fax Number :
 Vendor Number :500000

Quotation Deadline Date : 20.08.2013
Quotation Deadline Time : 12:00

REQUEST for QUOTATION
 Transnet Capital Projects
RFQ Number / Date
 6000170533 / 13.08.2013
Contact Person / Telephone
 Eddie Quinn / 035 905 3664
Return to VAX Number/EMAIL
 0865169978 / TCPtendersRichardsBay@Transnet.net

"PREVIEW COPY ONLY"

Item	Material	Description	RFQ Qty	UoM	Required Del date	Confirm Del date	Unit Price Excl	Total Price Excl
00160		Clamping Bracket as per	32	ea	30.08.2013			
Clamping Bracket as per Drg.CEE -TMFB-138								
00170		Clamping Bracket as per	32	ea	30.09.2013			
Clamping Bracket as per Drg. CEE -TMFB -145								
00180		Tie Bar .Deminsion "A"3	32	ea	30.08.2013			
Tie Bar .Deminsion "A"3200mm as per Drg.TMHB -3								
00190		Adaptor Plate as per Dr	50	ea	30.08.2013			
Adaptor Plate as per Drg. CEE - TNE - 33								



Transnet SOC Limited
T/A Transnet Capital Projects
 Company
 TFR Tender Board - JHB.
 TFR Tender Board.
 Johannesburg.
 2000

REQUEST FOR QUOTATION

Registration Number: 1990/000900/06
Vat Number : 4720103177

Attention:
 TFR Official Tender Board.
 Telephone Number :
 Fax Number :
 Vendor Number :500000

Quotation Deadline Date : 20.08.2013
Quotation Deadline Time : 12:00

REQUEST for QUOTATION
 Transnet Capital Projects
RFQ Number / Date
 6000170533 / 13.08.2013
Contact Person / Telephone
 Eddie Quinn / 035 905 3664
Return to VAX Number/EMAIL
 0865159978 / TCPtendersRichardsBay@Transnet.net

Item	Material	Description	RFQ Qty	UoM	Required Del date	Confirm Del date	Unit Price Excl	Total Price Excl
00200		Push Pull Off Adaptor P	4	ea	30.08.2013			

Push Pull Off Adaptor Plate as per Drg. CEE -TN-135.

Transnet Limited t/a Transnet Freight Rail (R.M.E.) # Richards Bay, hereby invite your company to submit a detailed quotation for:

The Manufacture, Deliver and Offload of Various steel brackets and fittings, as requested above, and to Transnet Specifications & Drawings, delivered to 1 Morris Road - Empangeni Rail - Old Goods Shed.

All technical queries relating to this invitation may be addressed to;
 Mr. Pierre Crocker Tel: 083 279 0437 / 035-905 3638.

All tender related queries pertaining to this invitation may be addressed to;
 Mr. Eddie Quinn, Tel: 035 # 905 3664.

The closing time for receipt of your official quotations is 12:00 hours on Tuesday, 20 August 2013.

Telephonic and late quotes will not be accepted.
 All quotations should be clearly marked, forwarded to:
 Me Yogeshnie Gengan, Tender & Fax Assistant,
 Fax No: 086 515 9978 or 031-830 0000, and / or

"PREVIEW COPY ONLY"



Transnet SOC Limited
T/A Transnet Capital Projects
 Company
 TFR Tender Board - JHB.
 TFR Tender Board.
 Johannesburg.
 2000

REQUEST FOR QUOTATION

Registration Number: 1990/000900/06
Vat Number : 4720103177

Attention:
 TFR Official Tender Board.
 Telephone Number :
 Fax Number :
 Vendor Number :500000

Quotation Deadline Date : 20.08.2013
Quotation Deadline Time : 12:00

REQUEST for QUOTATION
 Transnet Capital Projects
RFQ Number / Date
 6000170533 / 13.08.2013
Contact Person / Telephone
 Eddie Quinn / 035 905 3664
Return to VAX Number/EMAIL
 0865139978 / TCPtendersRichardsBay@Transnet.net

Item	Material	Description	RFQ Qty	UoM	Required Del date	Confirm Del date	Unit Price Excl	Total Price Excl
------	----------	-------------	---------	-----	-------------------	------------------	-----------------	------------------

e-mailed to: TCPtendersRichardsBay@transnet.net

The contractor's address and identification details have to be shown on each quotation submitted.

Please supply the following documents with your quotation submitted.

- Valid Tax Clearance certificate.
- Copy of your latest B.B.B.E.E. Certificate.
- Certificate of good standing with the Workman's Compensation Commissioner.

Failing to submit any of the documents mentioned above could result in your quotation to be disqualified / not accepted.



Note: #Transnet may not necessarily accept the lowest or any other offer and reserves the right to select in its favor any or, a portion of any offer made"

If you are unable to quote for this RFQ, please submit a NO QUOTE, with a short reasons, if possible, for not being able to quote.

Otherwise we look forward to receive your detailed quote by the date and time stated.

Yours faithfully,

"PREVIEW COPY ONLY"



Transnet SOC Limited
T/A Transnet Capital Projects
 Company
 TFR Tender Board - JHB.
 TFR Tender Board.
 Johannesburg.
 2000

REQUEST FOR QUOTATION

Registration Number: 1990/000900/06
Vat Number : 4720103177

Attention:
 TFR Official Tender Board.
 Telephone Number :
 Fax Number :
 Vendor Number :500000

Quotation Deadline Date : 20.08.2013
Quotation Deadline Time : 12:00

REQUEST for QUOTATION
 Transnet Capital Projects
RFQ Number / Date
 6000170533 / 13.08.2013
Contact Person / Telephone
 Eddie Quinn / 035 905 3664
Return to VAX Number/EMAIL
 0865159978 / TCPtendersRichardsBay@Transnet.net

Delivery Address

For: TFR (RME) Richards Bay.
 1 Morris Road - Jan Ayres 083 263 0845.
 Mr Pierre Crocker - Tel: 083 279 0437.
 3900

This RFQ is subject to the following conditions:

1. Price/s : The price/s quoted in SA currency and is excluding of V.A.T
2. Delivery : The price/s quoted should include delivery cost to the delivery address stated on the RFQ
3. Returnables : A valid tax clearance certificate and BBBEE certificate from a SANAS accredited verification agency attached to quotation for all quotes above R30 000.
Please note that only the official Transnet RFQ will be accepted and all other correspondence to be attached to the original
4. Safety : To confirm to Transnet Capital Projects Health & Safety plan and specification; HAS-std-0001, copy available on request.
5. Confirmation: To confirm your participation in this tender process please sign and return this document as immediate effect prior to the quotation deadline.
6. Negotiations: The Employer may elect to negotiate the final terms of the contract/order with the preferred tenderer in accordance with Clauses F.2.17 and F.3.13 of the CIDB Standard Conditions of Tender. A copy of which is available upon request.

Signature _____

Date _____

Qsa: 103 336 09

ITEM	DESCRIPTION	QTY	STORES ITEM NO	DRG NO CEE-
1	STEEL, FLAT, 65 X 12 THK X 130 LG (11/1961)	2		
2	STEEL, ROUND, ϕ 36 X 410 LG	1		

AMENDMENTS		
NO	NAME	DATE
1	J HARCUS	95-08-21

REVISED, WAS PART OF DRG NO CEE-TMF-332. DO REF T95/050

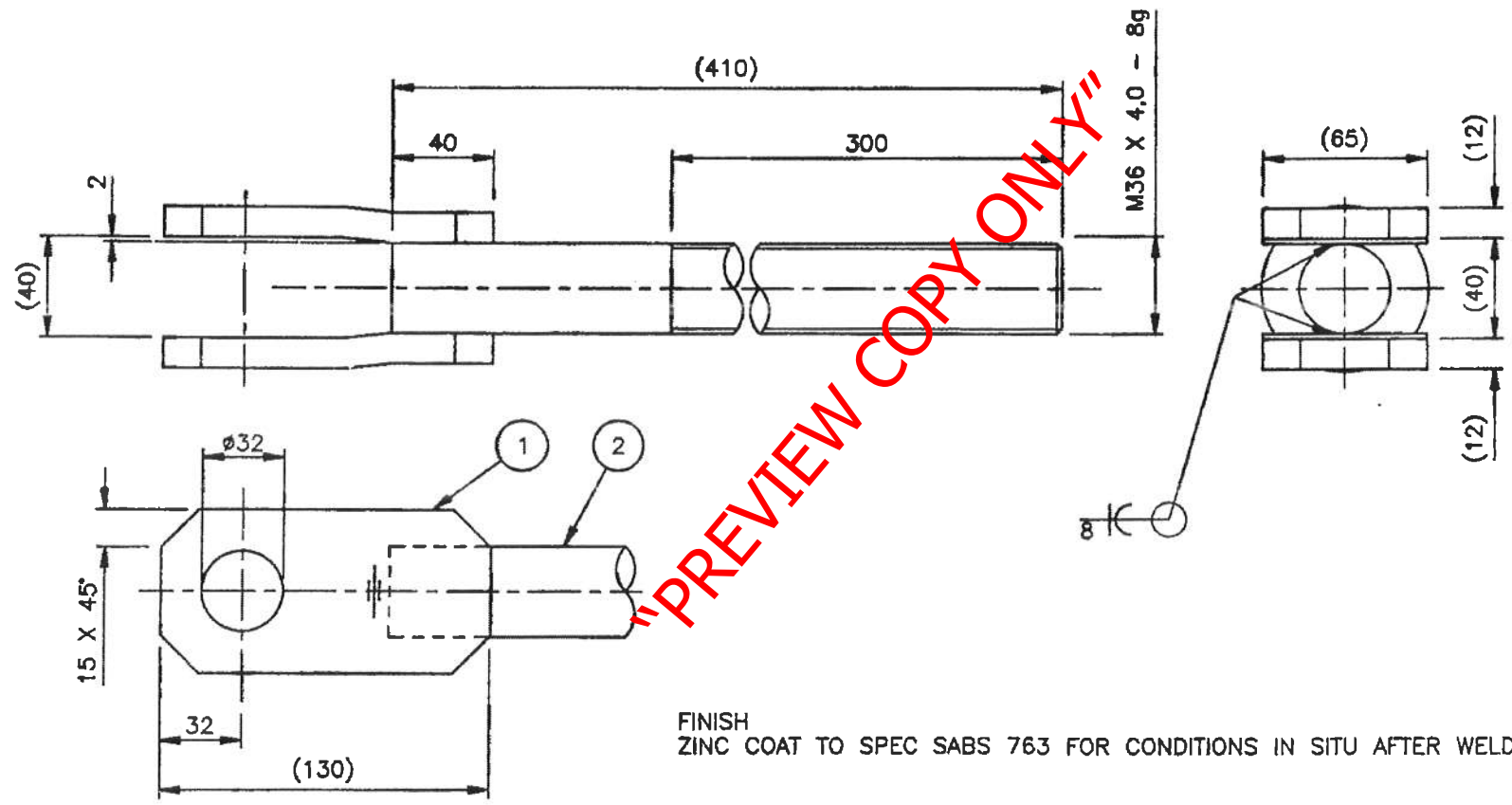

FINISH
ZINC COAT TO SPEC SABS 763 FOR CONDITIONS IN SITU AFTER WELDING

DIMENSION: mm
SCALE: 1:2

A3

DO REF: T79/20 GEN TOL: LIN \pm 1 ANG \pm -
 DRN: B v d WESTH CKD: J SWIEGERS DATE: 80-07-28
 ENG: - GA WILLIAMS for CHIEF ENG

STAY BOLT
STAY WIRE

DRAWING NO CEE-
TNE-31
SHEET 2 OF 3

INFRASTRUCTURE
(ELECTRICAL)



T0000936

Ref: 10333610

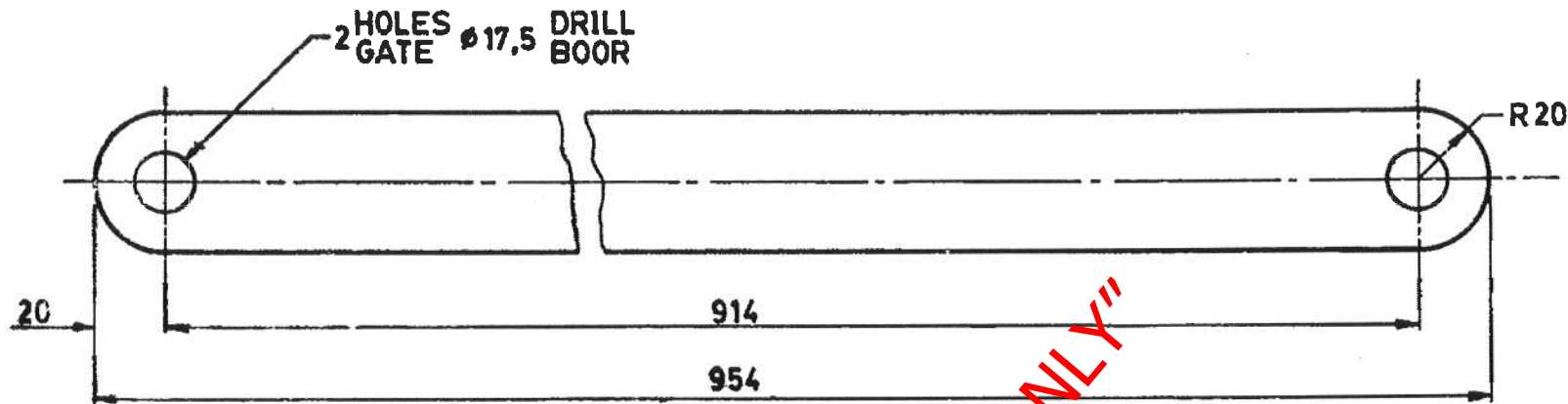

DIMENSIONS : MILLIMETRES
AFMETINGS : MILLIMETER

MATERIAL-MATERIAAL
 STEEL, FLAT
 STAAL, PLAT 40 x 12 = 954 L
 STORES ITEM
 MAGASYNITEM NO. 11/12494
 SPEC. CME 9 SYM. 7
 SPES. CME 9 SIM. 7
 OR COMMERCIAL GRADE
 OF HANDELSGRAAD

FINISH/AFWERKING
 ZINC COAT TO SPEC.
 SINKBELER VOLG. SPES. S.A.B.S. 763

ELANDSFONTEIN DRG/TEK NO.
TW 568/26/23

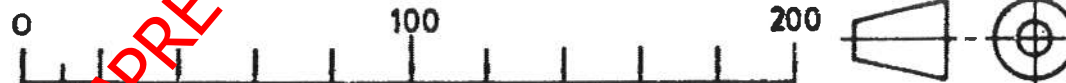

DRN. GET. M. K.	GEN. TOLERANCES: LIN. ± 0,5 ALG. TOLERANSIES: ANG/HOEK _____	
TRCD. NGT. W. F. MANS	D.O. REF. TK-VERW C 227/68	ENG. IR K. KALMER
CKD. NGS. F.W.C.	DATE DATUM 18-04-69	_____ for. _____ ns.

CHIEF ELECTRICAL ENGINEER
ELEKTRIESE HOOFINGENIEUR

JOHANNESBURG

SOUTH AFRICAN TRANSPORT SERVICES
SUID-AFRIKAANSE VERVOERDIENSTE



EXTENSION STRAP.
914 HOLE CENTRES.

VERLENGSTROOK.
914 GATSENTERS.

AMENDMENTS WYSIGINGS		
NO.	NAME NAAM	DATE DATUM
1.	B.J.vd.W.	87-07-03
REDRAWN AND RE- VISED. DRG. NO. WAS CEE - 54 / 110216. OORGETEKEN EN HERSIEN. TEK. NO. WAS CEE - 54 / 110216. D. O. REF. T 87 / 36 TK-VERW.		
CEE-TP-72 CEE-TPB-1 CLASS/ASSY. DRG. KLAS/SAMEST.-TEK.		
STORES ITEM MAGASYNITEM NO.		
54 / 2247		
DRAWING TEKENING NO. CEE-		
TNE-1		
SHEET 1 OF 1 VEL 1 VAN 1.		

Req: 10333619

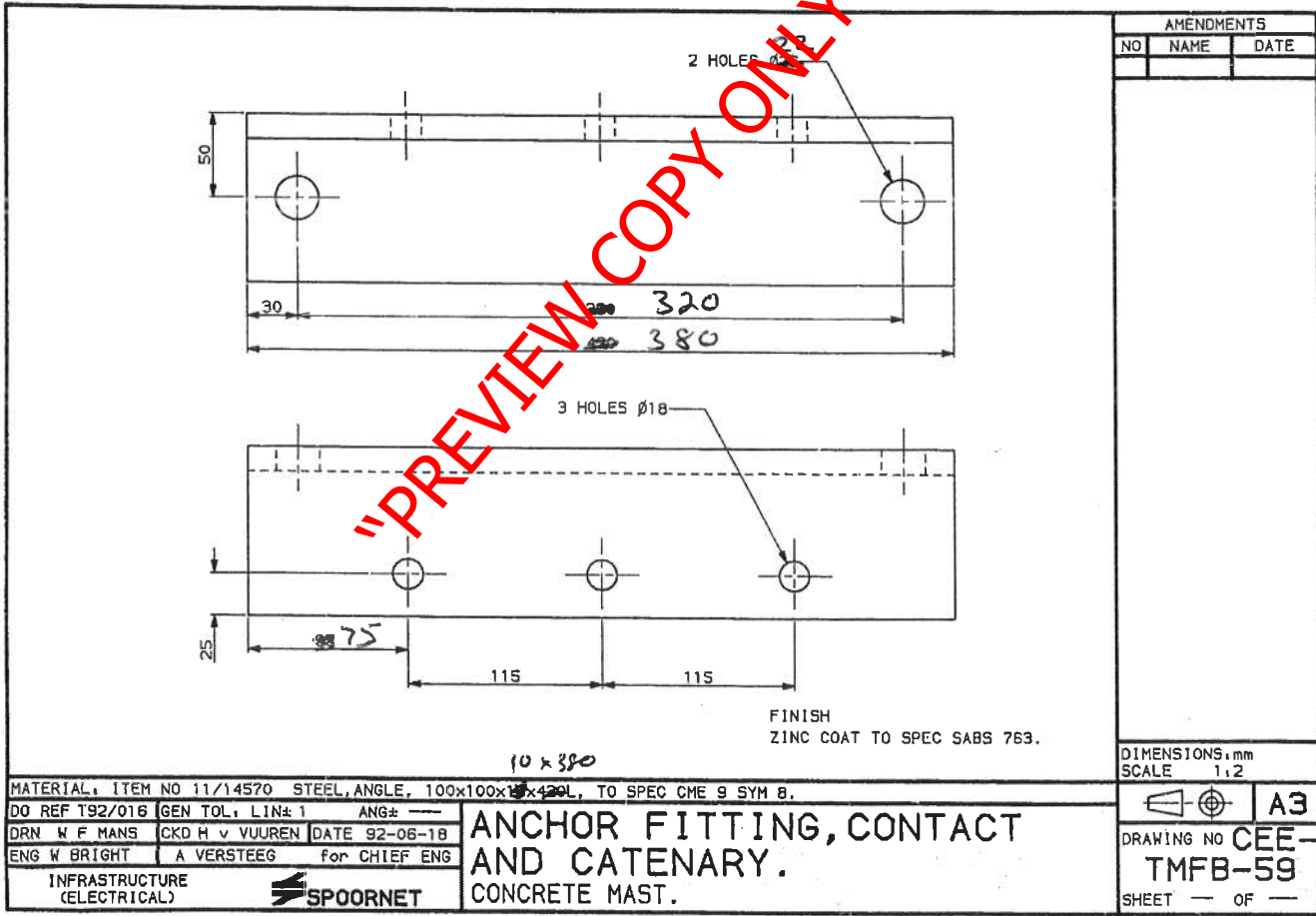

AMENDMENTS		
NO	NAME	DATE

DIMENSIONS, mm
SCALE 1:2

MATERIAL: ITEM NO 11/14570 STEEL, ANGLE, 100x100x10x420L, TO SPEC CME 9 SYM 8.				A3 DRAWING NO CEE- TMFB-59 SHEET — OF —
DO REF T92/016	GEN TOL: LIN# 1	ANG# —	ANCHOR FITTING, CONTACT AND CATENARY. CONCRETE MAST.	
DRN W F MANS	CKD H v VUUREN	DATE 92-06-18		
ENG W BRIGHT	A VERSTEEG	for CHIEF ENG	INFRASTRUCTURE (ELECTRICAL)	SPOORNET

Ref: 10333618

AMENDMENTS		
NO	NAME	DATE
2	JVT	97-09-05

DRAWING REVISED.
DO REF: T96/021

FOUNDATION	DIMENSION "A"
K	1 700
L	1 800
M	2 100
N	2 500

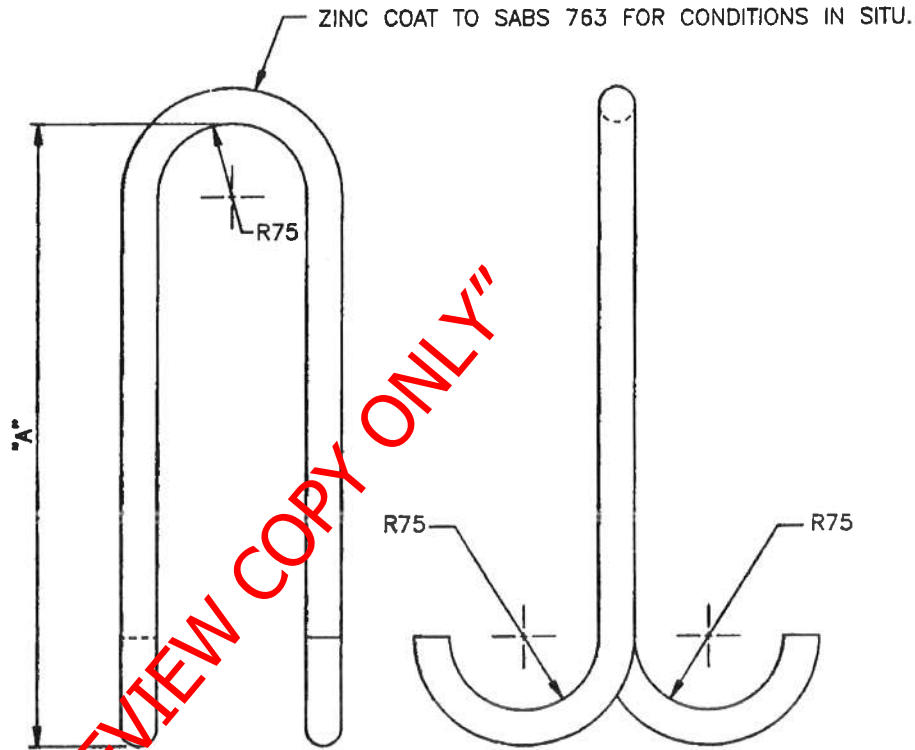

"PREVIEW COPY ONLY"

NOTE
THIS DRAWING TO BE READ IN CONJUNCTION WITH DRG NO CEE-TQ-43.

DIMENSIONS: mm
SCALE: 1:5

A3

DRAWING NO CEE-
TQ-53

SHEET — OF —

MATERIAL: STEEL, ROUND $\phi 36$ TO SPEC BS 4360 GRADE 43A.

DO REF: T1/81/38 GEN TOL: LIN \pm 1 ANG \pm —

DRN: J KRÜGER CKD: B STEWART DATE: 81-08-20

ENG: — L RICHARDS for CHIEF ENG

HOOK, FOUNDATION, STAYWIRE

INFRASTRUCTURE
(ELECTRICAL)



Req: 103 336 17

ITEM	DESCRIPTION	QTY	STORES	ITEM NO	DRG NO	AMENDMENTS		
						NO	NAME	DATE
1	BRACKET, STAY WIRE ATTACHMENT				TMFB-57			
2	GUSSET PLATE				TMFB-16	TMFB-175		

FINISH
ZINC COAT TO SPEC SABS 763.

Mod

DO REF T92/016	GEN TOL, LIN# 1	ANG# —
DRN W F MANS	CKD H v VUUREN	DATE 92-06-18
ENG W BRIGHT	A VERSTEEG	for CHIEF ENG

INFRASTRUCTURE (ELECTRICAL) **SPOORNET**

ATTACHMENT, STAY WIRE
CONCRETE MAST.

DIMENSIONS, mm	A3
SCALE 1:2	
DRAWING NO CEE-	
TMFB-58	
SHEET — OF —	

Req. 10333616

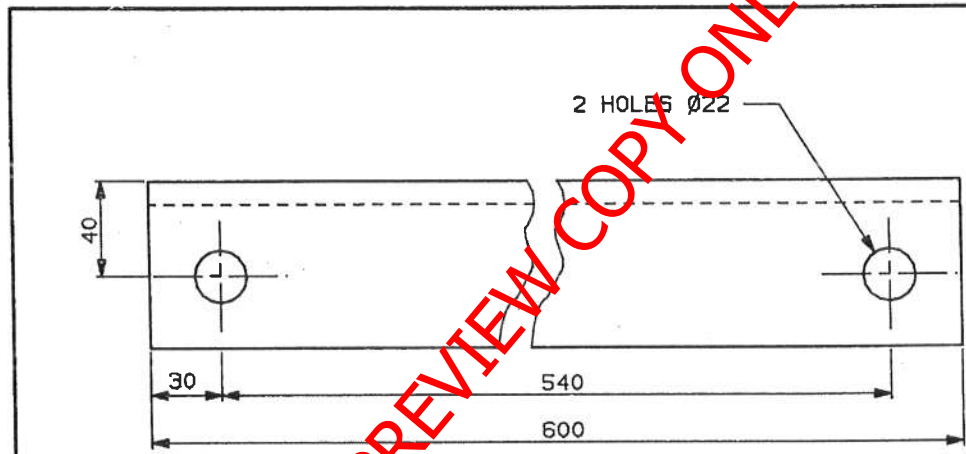

"PREVIEW COPY ONLY"

FINISH
ZINC COAT TO SABS 763.

AMENDMENTS		
NO	NAME	DATE

DIMENSIONS: mm
SCALE 1:2

MATERIAL: ITEM NO 11/14508 STEEL, ANGLE, 70x70x10x600L, TO SPEC CME 9 SIM 8
 DO REF T92/014 GEN TOL, LIN# 1 ANG# —
 DRN W F MANS CKDH v VUUREN DATE 92-07-10
 ENG W BRIGHT A VERSTEEG for CHIEF ENG

BRACKET, CLAMPING

70x70x10 ANGLE IRON.
440 HOLE CENTRES

A 4
 DRG NO CEE-
TMFB-55
 SHT — OF —

INFRASTRUCTURE
(ELECTRICAL)



REF 103 336 15

ITEM	DESCRIPTION	QTY	STORES	ITEM NO	DRG NO	CEE-	AMENDMENTS		
							NO	NAME	DATE
1	STEEL, FLAT, 50 x 10 x 415L TO SPEC CME 9 SYM 8 (11/12381)	2							
2	STEEL, FLAT, 100 x 6 x 100L TO SPEC CME 9 SYM 8 (11/12319)	2							
3	STEEL, FLAT, 50 x 12 x 600L TO SPEC CME 9 SYM 8 (11/12509)	2							

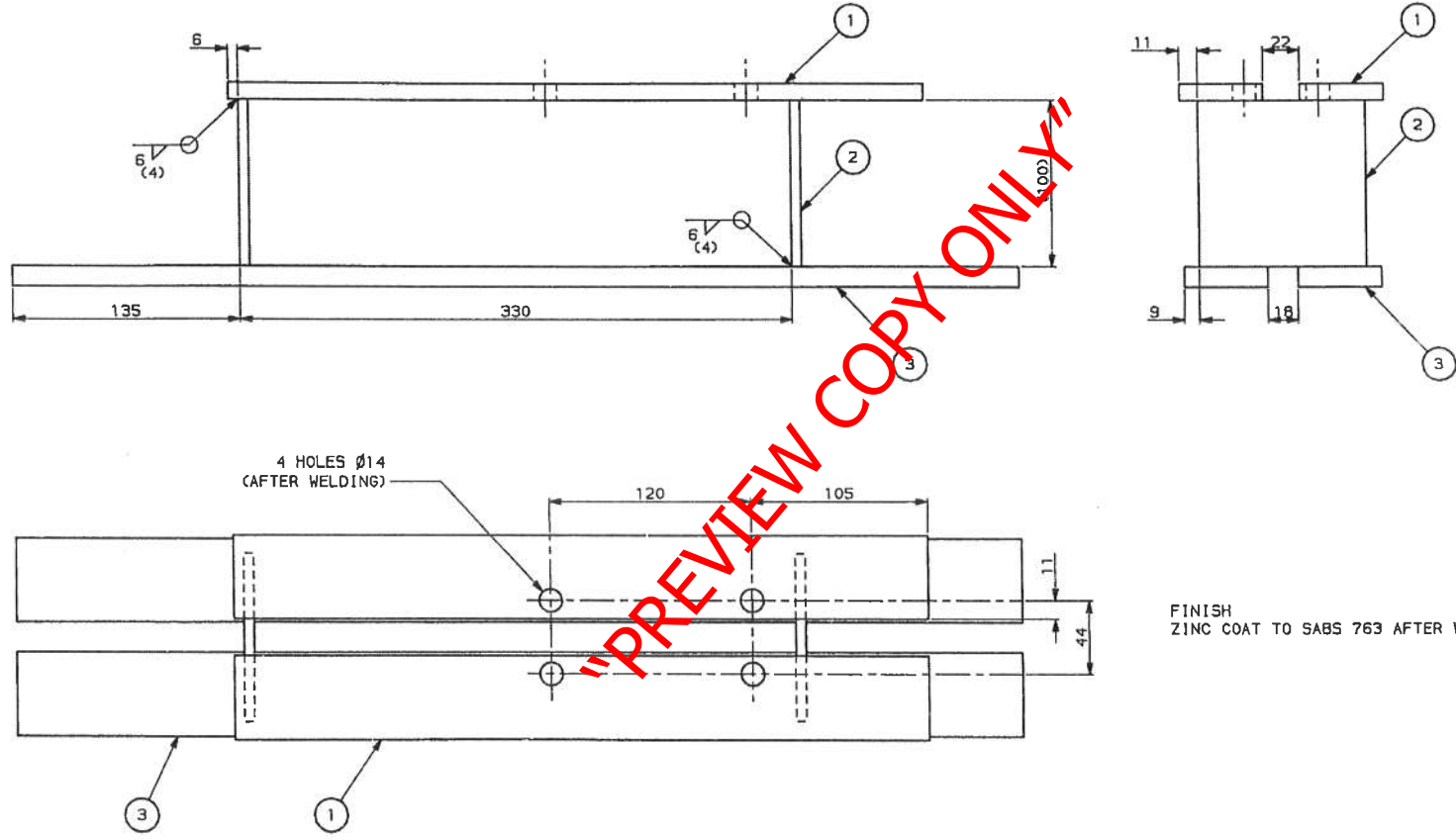

FINISH
ZINC COAT TO SABS 763 AFTER WELDING

DIMENSIONS: mm	
SCALE: 1:2	
	A2
DRAWING NO CEE-	
TMFB-69	
SHEET -- OF --	

DO REF T92/014	GEN TOL. LIN±1	ANG±1
DRN W F MANS	CKD H v VUUREN	DATE 92-07-10
ENG W BRIGHT	A VERSTEEG	for CHIEF ENG
INFRASTRUCTURE (ELECTRICAL)		

OPERATING HANDLE MOUNTING ASSEMBLY
SWITCH STRUCTURE
CONCRETE MAST. 3kV DC.

Rso 103336 V

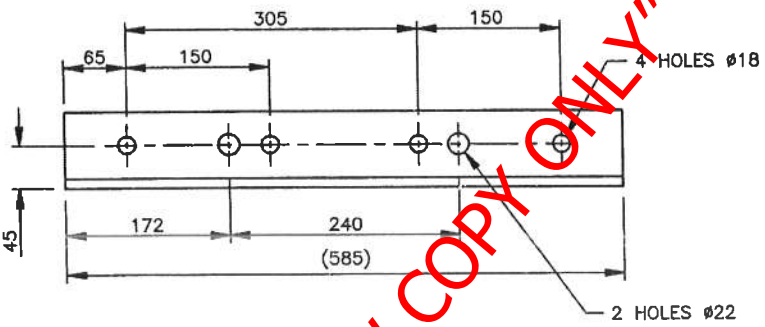

PREVIEW COPY ONLY

ITEM 1: NOT ZINC COATED.
 ITEM 2: ZINC COAT TO SABS 763 FOR CONDITIONS IN SITU.

AMENDMENTS		
NO	NAME	DATE
1	L E WOOD	96-08-01
REDRAWN. DRG NO WAS CEE-TMHA-138. DO REF: T96/009		

STORES ITEM NO.
 DIMENSIONS: mm
 SCALE: 1:5

MATERIAL: ITEM NO 11/14521, STEEL, ANGLE, 80 x 80 x 10 THK x 585 LG

DO REF: Y77/16	GEN TOL: LIN± 1 ANG±
DRN: B GORDON	CKD: J JACKSON DATE: 79-06-06
ENG:	GA WILLIAMS for CHIEF ENG

CLAMPING BRACKET
 SWITCH MOUNTING PLATFORM
 OHTE SWITCH STRUCTURES

INFRASTRUCTURE
 (ELECTRICAL)



 **A4**
 DRG NO **CEE-TMC-103**
 SHT - OF -

T0001029

Δ
3

Δ

Δ
4

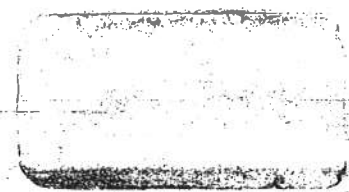

Δ
4

Δ

Δ
3

REF: 10333613

TMC-103

ITEM	DESCRIPTION ~ BESKRYWING	QTY	STORES	NO	DATE	AMENDMENTS
1	CLAMPING BRACKET, SWITCH MOUNTING PLATFORM Klampstelsel, skakelaarmonteerplatform	1	M/11/14021			
2	STEEL, CHANNEL STAAL, KANAAL 140 x 60 x 10 kg/m = 225 L	1	M/11/014711			NO. NAME DATE 1. T. Mosen 82-05-29.
3	STEEL, CHANNEL STAAL, KANAAL 127 x 84 x 14,8 kg/m = 1300 L	1	M/11/011802			REDRAWN IN INK. DOORGETEKEN IN INK. T.K.-VERW. T1/21/74.
4	STEEL, CHANNEL STAAL, KANAAL 127 x 84 x 14,8 kg/m = 680 L	1	M/11/011802			
5	STEEL, PLATE STAAL, PLAAT 140 x 140 x 8 THICK DIK	1	11/			
6	STEEL, PLATE STAAL, PLAAT 80 x 140 x 8 THICK DIK	2	11/			

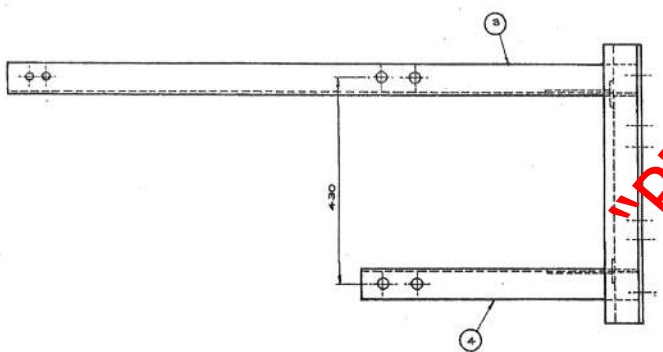
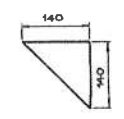
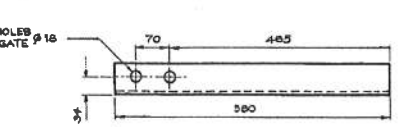
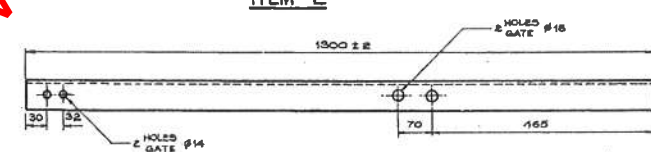
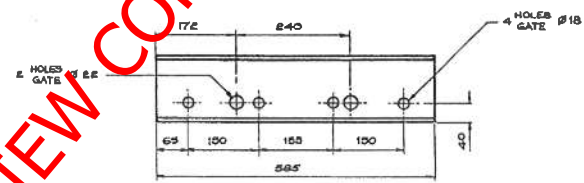
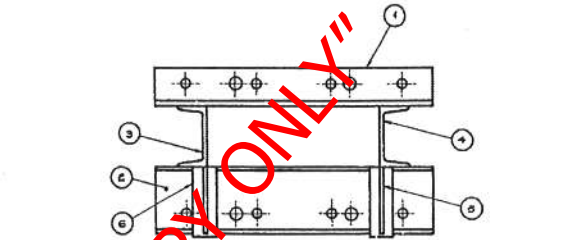
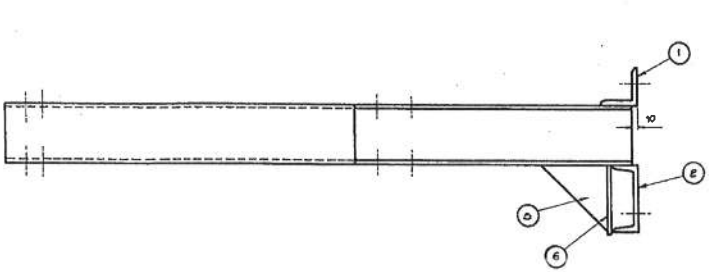

- NOTES ~ OPMERKINGS
1. THIS PLATFORM IS SUITABLE FOR MOUNTING OF B.B.C. TYPE SWITCH.
HIERDIE PLATFORM IS GESKIK VIR DIE MONTERING VAN B.B.C. TIEP SKAKELAAR.
 2. WELDED CONSTRUCTION
SWIELS KONSTRUKSIE
 3. ZINC COAT TO
BINKBEDEK VOLGENS SABS 703 AFTER WELDING.
NA SWIELSWERK.

"PREVIEW COPY ONLY"

DESIGNER: GEN. TOLRANCES: LIN ± 0.1 ANG/HOEK ± 1°	DATE: 20/06/12
CHKD: R.A. MILLAN	DATE: 20/06/12
ENG: G.A. WILLIAMS	DATE: 22/06/12
CHIEF ELECTRICAL ENGINEER JOHANNESBURG.	
ELECTRIESE HOOFINGENIEUR JOHANNESBURG.	
SOUTH AFRICAN TRANSPORT SERVICES	
SUID-AFRIKAANSE VERVOERDIENSTE	

PLATFORM, SWITCH MOUNTING.
25kV AC AUTO TENSIONED CONSTRUCTION.
PLATFORM, SKAKELAARMONTERING.

CEE - TMS - 03
ASSY DRG / SAMEST-TEK
DRAWING NO. CEE-
TMF-351

TMF-351

Rea 10333613

AMENDMENTS		
NO	NAME	DATE
1	L E WOOD	96-08-01
REDRAWN. DRG NO WAS CEE-TMHA-138. DO REF: T96/009		
STORES ITEM NO.		
DIMENSIONS: mm SCALE: 1:5		
MATERIAL: ITEM NO 11/14521, STEEL ANGLE, 80 x 80 x 10 THK x 585 LG DO REF: Y77/16 GEN TOL: LIN± .1 ANG± — DRN: B GORDON CKD: J JACKSON DATE: 79-06-06 ENG: — GA WILLIAMS for CHIEF ENG		DRG NO CEE-TMC-103 SHT — OF —
INFRASTRUCTURE (ELECTRICAL)		CLAMPING BRACKET SWITCH MOUNTING PLATFORM OHTE SWITCH STRUCTURES

"PREVIEW COPY ONLY"

ITEM 1: NOT ZINC COATED.
 ITEM 2: ZINC COAT TO SABS 763 FOR CONDITIONS IN SITU.

A4
 DRG NO CEE-TMC-103
 SHT — OF —

T0001029

3 Δ 4 Δ 4 Δ 3

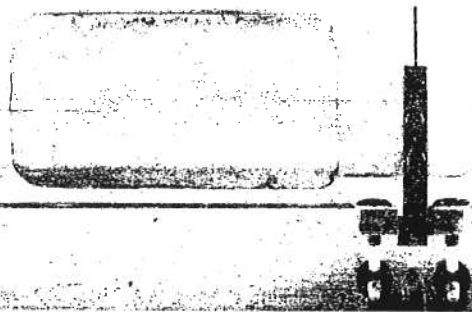

Req: 10333612

MAST# - TRACK#	DIM "A"	ITEM	DESCRIPTION	QTY		STORES ITEM NO	DRG NO CEE-	AMENDMENTS		
				IB	UC			NO	NAME	DATE
2750	1000	1	CLAMPING BRACKET	-	1	TMFB-145	TMFB-67 ITEM 1	1	A V	92-08-04
3200	1000	2	CLAMPING BRACKET	1	-		TMFB-99 ITEM 1	DRG NO WAS CEE-TMF-364 SHT 1.		
3700	1000	3	STEEL, ANGLE 70x70x6x"A" L SPEC CME 9 SYM B (11/---)	1	1			ITEM 4 DRG NO WAS CEE-TMHA-182.		
		4	GUSSET	1	1		TMFB-66 ITEM 1	DO REF T91/037		
		5	WIRE, STEEL, ROUND Ø8x60L (11/2727)	1	1					

SEE DETAIL "B"

DETAIL "B"

NOTE
WELDING TO CONFORM TO BS 5135

FINISH
ZINC COAT TO SPEC SABS 763

DO REF T80/50	GEN TOL, LIN±1	ANG±2°	ELECTRIFICATION TYPE, 9KV DC FIXED CANTILEVER. STEADY ARM ATTACHMENT WITH LOCKING BRACKET PUSH-PULL-OFF ARRANGEMENTS. 203 x 203 UNIVERSAL COLUMNS AND 1-MASTS.
DRN J. KRÜGER	CKD J. SWIEGERS	DATE 80-06-11	
ENG _____	F. PIENAAR	For CHIEF ENG	

INFRASTRUCTURE (ELECTRICAL)	
-----------------------------	--

DIMENSIONS, mm	
SCALE 1:10, 1:5	
DRAWING NO CEE-	A3
TMFB-67	
SHEET 1 OF 2	

