



Transnet SOC Limited
T/A Transnet Capital Projects

REQUEST FOR QUOTATION

TFR Tender Board - JHB.
TFR Tender Board.
Johannesburg.
2000

Registration Number: 1990/000900/06
Vat Number : 4720103177

Attention:
TFR Official Tender Board.
Telephone Number :
Fax Number :
Vendor Number :500000

Quotation Deadline Date : 19.08.2013
Quotation Deadline Time : 12:00

REQUEST for QUOTATION
Transnet Capital Projects
RFQ Number / Date
6000170292 / 12.08.2013
Contact Person / Telephone
Eddie Quinn / 035 905 3664
Return to VAX Number/EMAIL
0865159978 / TCPtendersRichardsBay@Transnet.net

"PREVIEW COPY ONLY"

Item	Material	Description	RFQ Qty	UoM	Required Del date	Confirm Del date	Unit Price Excl	Total Price Excl
00010		Parallel Clamp 160mm -	150	ea	28.08.2013			
Parallel Clamp 160mm - 100mm/80mm as per Drg.CEE-TNB-55								
00020		Parallel Clamp 161mm CU	150	ea	28.08.2013			
Parallel Clamp 161mm CU Contact Wire to 160mm Conductor as per Drg.CEE-TNB-0057								
00030		Attachment Fitting Tow	150	ea	28.08.2013			
Attachment Fitting Tower Hook as per Drg.CEE -TNB -71								
00040		Attachment Fitting Univ	300	ea	28.08.2013			



Transnet SOC Limited
T/A Transnet Capital Projects
 Company
 TFR Tender Board - JHB.
 TFR Tender Board.
 Johannesburg.
 2000

REQUEST FOR QUOTATION

Registration Number: 1990/000900/06
Vat Number : 4720103177

Attention:
 TFR Official Tender Board.
 Telephone Number :
 Fax Number :
 Vendor Number :500000

Quotation Deadline Date : 19.08.2013
Quotation Deadline Time : 12:00

REQUEST for QUOTATION
 Transnet Capital Projects
RFQ Number / Date
 6000170292 / 12.08.2013
Contact Person / Telephone
 Eddie Quinn / 035 905 3664
Return to VAX Number/EMAIL
 0865159978 / TCPtendersRichardsBay@Transnet.net

Item	Material	Description	RFQ Qty	UoM	Required Del date	Confirm Del date	Unit Price Excl	Total Price Excl
------	----------	-------------	---------	-----	-------------------	------------------	-----------------	------------------

Attachment Fitting Universal Type as per Drg-TNB-64

Transnet Limited t/a Transnet Freight Rail (R.M.E.) # Richards Bay, hereby invite your company to submit a detailed quotation for:

The Supply, Deliver and Offload of Various OHTE Attachment Items, as mentioned above, and to Transnet Specifications & Drawings, delivered to 1 Morris Road - Empangeni Rail - Old Goods Shed.

All technical queries relating to this invitation may be addressed to;
 Mr. Pierre Crocker Tel: 083 279 0437 / 035-905 3638

All tender related queries pertaining to this invitation may be addressed to;
 Mr. Eddie Quinn, Tel: 035 # 905 3664.

The closing time for receipt of your official quotations is 12:00 hours on Monday, 19 August 2013.

Telephonic and late quotes will not be accepted.
 All quotations should be clearly marked, and forwarded to:
 Me Qetelo Moshoeshe, Tender & Fax Assistant,
 Fax No: 086 515 9978 or 031-830 0000, and / or
 e-mailed to: TCPtendersRichardsBay@transnet.net

The contractor's address and identification details have to be shown on each quotation submitted.

PREVIEW COPY ONLY



Transnet SOC Limited
T/A Transnet Capital Projects
 Company
 TFR Tender Board - JHB.
 TFR Tender Board.
 Johannesburg.
 2000

REQUEST FOR QUOTATION

Registration Number: 1990/000900/06
Vat Number : 4720103177

Attention:
 TFR Official Tender Board.
 Telephone Number :
 Fax Number :
 Vendor Number :500000

Quotation Deadline Date : 19.08.2013
Quotation Deadline Time : 12:00

REQUEST for QUOTATION
 Transnet Capital Projects
RFQ Number / Date
 6000170292 / 12.08.2013
Contact Person / Telephone
 Eddie Quinn / 035 905 3664
Return to VAX Number/EMAIL
 0865159978 / TCPtendersRichardsBay@Transnet.net

PREVIEW COPY ONLY

Item	Material	Description	RFQ Qty	UoM	Required Del date	Confirm Del date	Unit Price Excl	Total Price Excl
------	----------	-------------	---------	-----	-------------------	------------------	-----------------	------------------

Please supply the following documents with your quotation submitted;

- Valid Tax Clearance certificate.
- Copy of your latest B.B.B.E.E. Certificate.
- Certificate of good standing with the Workman's Compensation Commissioner.
- Test Certificate for item required.

Failing to submit any of the documents mentioned above, could result in your quotation to be disqualified / not accepted.

Note: #Transnet may not necessarily accept the lowest or any other offer and reserves the right to select in its favor any or, a portion of any offer made"

If you are unable to quote for this RFQ, please submit a NO QUOTE, with a short reasons, if possible, for not being able to quote.

Otherwise we look forward to receive your detailed quote by the date and time stated.

Yours faithfully,



Transnet SOC Limited
T/A Transnet Capital Projects
 Company
 TFR Tender Board - JHB.
 TFR Tender Board.
 Johannesburg.
 2000

REQUEST FOR QUOTATION

Registration Number: 1990/000900/06
Vat Number : 4720103177

Attention:

TFR Official Tender Board.
 Telephone Number :
 Fax Number :
 Vendor Number :500000

Quotation Deadline Date : 19.08.2013
Quotation Deadline Time : 12:00

REQUEST for QUOTATION

Transnet Capital Projects

RFQ Number / Date

6000170292 / 12.08.2013

Contact Person / Telephone

Eddie Quinn / 035 905 3664

Return to VAX Number/EMAIL

0865159978 / TCPtendersRichardsBay@Transnet.net

Delivery Address

For: TFR (RME) Richards Bay.
 1 Morris Road - Jan Ayres 083 263 0845.
 Mr Pierre Crocker - Tel: 083 279 0437.
 3900

This RFQ is subject to the following conditions:

1. Price/s : The price/s quoted in SA currency and is excluding of V.A.T
2. Delivery : The price/s quoted should include delivery cost to the delivery address stated on the RFQ
3. Returnables : A valid tax clearance certificate and BBBEE certificate from a SANAS accredited verification agency attached to quotation for all quotes above R30 000.
Please note that only the official Transnet RFQ will be accepted and all other correspondence to be attached to the original
4. Safety : To confirm to Transnet Capital Projects Health & Safety plan and specification; HAS-std-0001, copy available on request.
5. Confirmation: To confirm your participation in this tender process please sign and return this document as immediate effect prior to the quotation deadline.
6. Negotiations: The Employer may elect to negotiate the final terms of the contract/order with the preferred tenderer in accordance with Clauses F.2.17 and F.3.13 of the CIDB Standard Conditions of Tender. A copy of which is available upon request.

Signature _____

Date _____

REQ: 10332786.

STORES ITEM NO	CONDUCTOR SIZES
54/000766	100mm ² / 80mm ² - 50mm ²
54/000791	100mm ² / 80mm ² - 100mm ² / 80mm ²
54/002728	160mm ² - 50mm ²
54/002753	160mm ² - 100mm ² / 80mm ²
54/002777	160mm ² - 160mm ²
54/000843	250mm ² - 50mm ²
54/000867	250mm ² - 100mm ² / 80mm ²
54/000880	250mm ² - 160mm ²
54/000907	250mm ² - 250mm ²

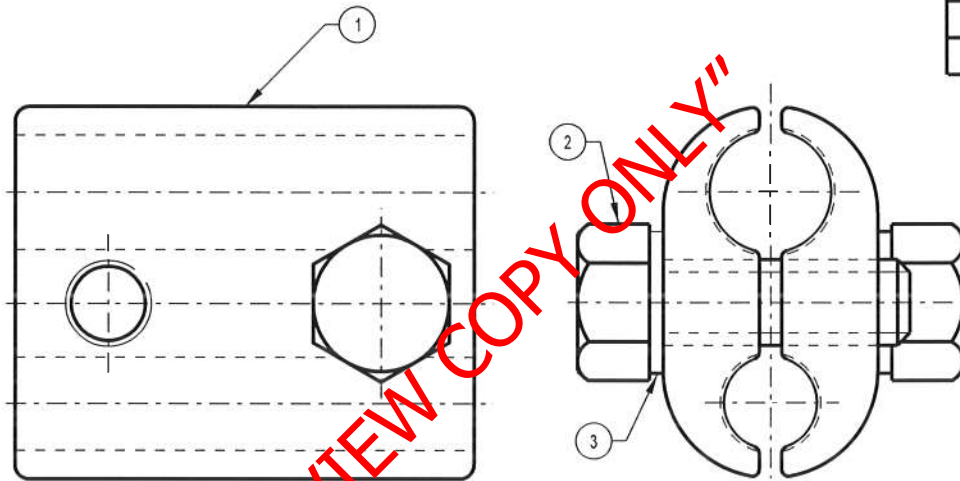

NOTE
Use Item 4 on the 250mm² side when this clamp is used for the 162mm² ACSR (Tiger) Catenary.

Item 3 Alternative material: Stainless steel to Specification AISI Grade 304.

4	Conductor splice liner, 162mm ² ACSR Catenary Wire (See Note)	2	-	CEE-TNB-0090
3	Washer, Lock, Phosphor Bronze, Internally Toothed, M12 to Specification BS.407.	2	54/002704	-
2	Screw, Machine, Cu-Ni-Si, Hex. Head, M12 x 6g - 35L to Specification CEE-0063.	2	54/003670	-
1	Parallel half clamp.	2	-	CEE-TNB-0054
ITEM NO	DESCRIPTION	QTY	STORES ITEM NO	DRAWING NO

© COPYRIGHT PROTECTED. PREPARED BY CENTRAL DRAWING OFFICE

DIMENSIONS : mm SCALE : 1:1
 TOLERANCE : LIN± - ANG± - ITEM NO: -
 MATERIAL :-
 VERSION INFO : TITLE REVISED.

Digitally signed by Ludwig Borchard
 Date: 2011.11.25 08:35:57 +02'00'
 APPROVED

Digitally signed by Ludwig Borchard
 Date: 2011.11.25 08:36:12 +02'00'
 AUTHORISED

PARALLEL CLAMP FOR VARIOUS CONDUCTOR SIZES.

TRANSNET
 freight rail
 CEE-TNB-0055
 AMENDMENT 5

A4

Req: 10332787

STORES ITEM NO	CONDUCTOR SIZES
54/000920	50mm ²
54/001949	100mm ² / 80mm ²
54/004930	160mm ²
54/004954	250mm ²

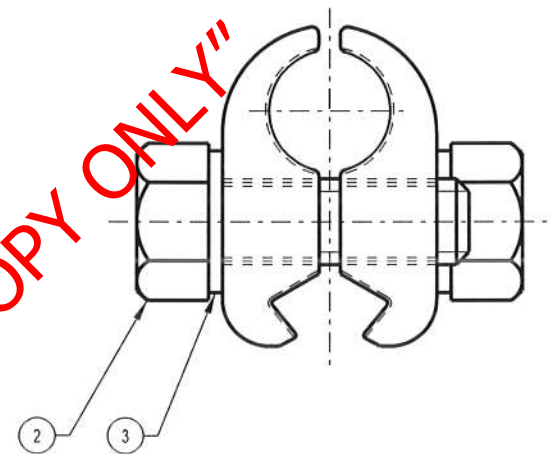
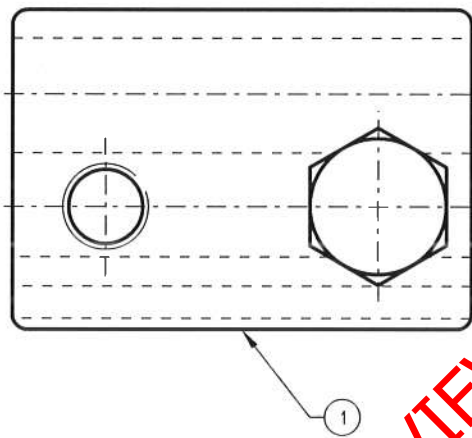

"PREVIEW COPY ONLY"

Item 3 Alternative material: Stainless steel to Specification AISI Grade 304.

ITEM NO	DESCRIPTION	QTY	STORES ITEM NO	DRAWING NO
3	Washer, Lock, Phosphor Bronze, Internally Toothed, M12 to Specification BS.407.	2	54/002704	-
2	Screw, Machine, Cu-Ni-Si, Hex. Head, M12 x 6g - 35L to Specification CEE-0063.	2	54/003670	-
1	Parallel half clamp.	2	-	CEE-TNB-0056

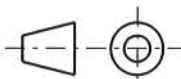

© COPYRIGHT PROTECTED. PREPARED BY CENTRAL DRAWING OFFICE

DIMENSIONS : mm SCALE : 1 : 1
 TOLERANCE : LIN± - ANG± - ITEM NO:-
 MATERIAL :-
 VERSION INFO : TITLE REVISED.

+ Digitally signed by
 Ludwig Borchard
 Date: 2011.11.25
 08:40:01 +02'00'
 APPROVED

+ Digitally signed by
 Ludwig Borchard
 Date: 2011.11.25
 08:40:21 +02'00'
 AUTHORISED

PARALLEL CLAMP FOR
 161mm² Cu. CONTACT WIRE

TRANSNET
 freight rail
 CEE-TNB-0057
 AMENDMENT 4

A4

DO REF: CDO/7537

ECP REF: BBF1590

DRAWN: C L BUCKLE

DESIGNED: -

CHECKED: J D VAN DYK

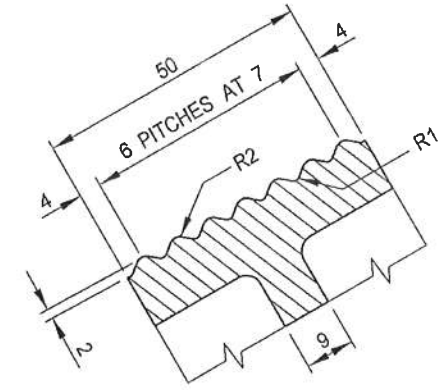
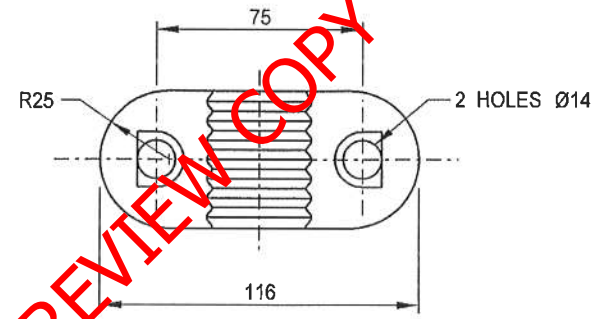
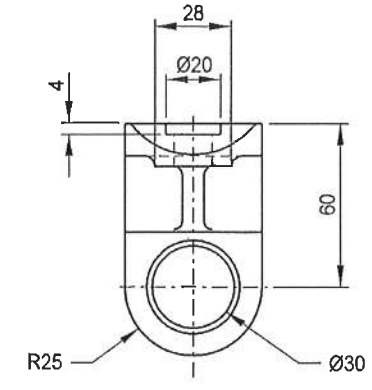
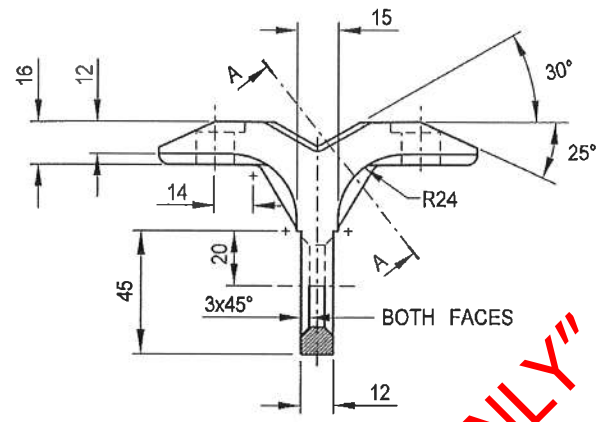
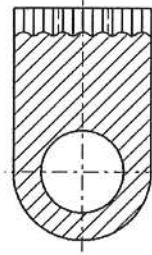

SECTION A-A
SCALE 1:1

"PREVIEW COPY ONLY"

NOTES

1. ALL UNSPECIFIED RADII TO BE R4.
2. THE FOLLOWING PERMANENT MARKINGS MUST APPEAR ON THIS ARTICLE:
 - a) TRANSNET.
 - b) MAKER'S IDENTIFICATION.
 - c) BATCH NUMBER.
3. FINISH: HOT DIP GALVANISE TO SANS 121.

© COPYRIGHT PROTECTED. PREPARED BY CENTRAL DRAWING OFFICE

DIMENSIONS : mm SCALE : 1:2
 TOLERANCE : LIN± 1 ANG± 1° ITEM NO : 54/11376
 MATERIAL : SPHEROIDAL GRAPHITE IRON, TO SPEC SANS 936
 GRADE SG 50.
 VERSION INFO : REDRAWN AND REVISED. TONGUE TAPER REMOVED.

DO REF : CDO/6517
 ECP REF : BBD5402
 DRAWN : C L BUCKLE
 DESIGNED : -
 CHECKED : J VAN DYK

DATE: 20/02/2009

 APPROVED

 AUTHORISED

ATTACHMENT FITTING.
 CANTILEVER STRUT, TOWER HOOK.

TRANSNET
freight rail
CEE-TNB-0071
AMENDMENT 3

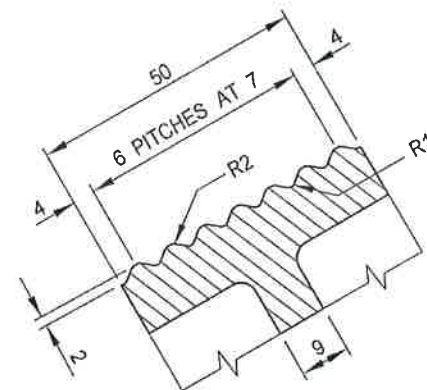
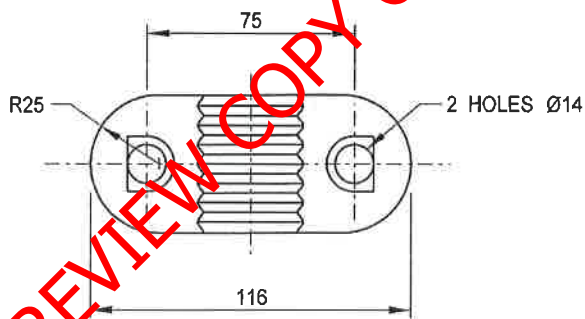
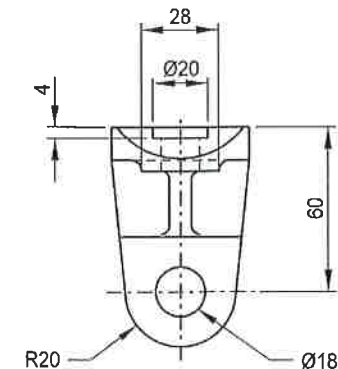
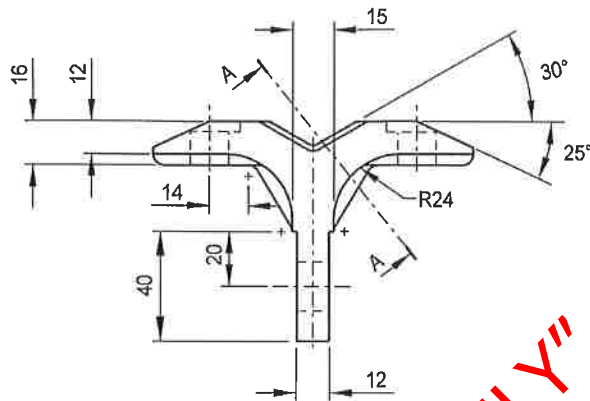
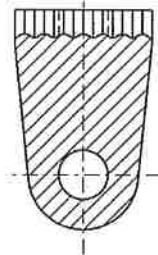

SECTION A-A
SCALE 1:1

"PREVIEW COPY ONLY"

NOTES

1. ALL UNSPECIFIED RADII TO BE R4.
2. THE FOLLOWING PERMANENT MARKINGS MUST APPEAR ON THIS ARTICLE:
 - a) TRANSNET.
 - b) MAKER'S IDENTIFICATION.
 - c) BATCH NUMBER.
3. FINISH: HOT DIP GALVANISE TO SANS 121.

© COPYRIGHT PROTECTED. PREPARED BY CENTRAL DRAWING OFFICE

DIMENSIONS : mm SCALE : 1 : 2
 TOLERANCE : LIN ± 1 ANG ± 1° ITEM NO : 54/11384
 MATERIAL : SPHEROIDAL GRAPHITE IRON, TO SPEC SANS 936
 GRADE SG 50.
 VERSION INFO : REDRAWN AND REVISED. TONGUE TAPER REMOVED.

DO REF : CDO/6517
 ECP REF : BBD5402
 DRAWN : C L BUCKLE
 DESIGNED : -
 CHECKED : J VAN DYK

DATE: 20/02/2009

APPROVED
 AUTHORIZED

ATTACHMENT FITTING.
 UNIVERSAL TYPE.



CEE-TNB-0064

AMENDMENT 2