



Transnet SOC Limited
T/A Transnet Capital Projects

REQUEST FOR QUOTATION

TFR Tender Board - JHB.
 TFR Tender Board
 Johannesburg.
 2000

Registration Number: 1990/000900/06
Vat Number : 4720103177

Attention:
 TFR Official Tender Board.
 Telephone Number :
 Fax Number :
 Vendor Number :500000

Quotation Deadline Date : 19.08.2013
Quotation Deadline Time : 12:00

REQUEST for QUOTATION
 Transnet Capital Projects
RFQ Number / Date
 6000170284 / 12.08.2013
Contact Person / Telephone
 Eddie Quinn / 035 905 3664
Return to FAX Number/EMAIL
 0865155078 / TCPtendersRichardsBay@Transnet.net

PREVIEW COPY

Item	Material	Description	RFQ Qty	UoM	Required Del date	Confirm Del date	Unit Price Excl	Total Price Excl
00010		Pin ,Straight , Headed	300	ea	23.08.2013			
		Pin ,Straight , Headed 16 Dia x 50 L complete with locking split pin as per Drg.CEE - TX-66.						
00020		Pin ,Straight, Headed 2	2	ea	23.08.2013			
		Pin ,Straight, Headed 24 Dia x 78 L complete with cotter pin as per Drg. CEE - TX -59.						
00030		Pin Stay Wire as per Dr	2	ea	23.08.2013			
		Pin Stay Wire as per Drg. CEE - TNE - 31 Sht 3						



REQUEST FOR QUOTATION

Transnet SOC Limited
 T/A Transnet Capital Projects
 Company
 TFR Tender Board - JHB.
 TFR Tender Board
 Johannesburg.
 2000

Registration Number: 1990/000900/06
 Vat Number : 4720103177

Attention:
 TFR Official Tender Board.
 Telephone Number :
 Fax Number :
 Vendor Number :500000

Quotation Deadline Date : 19.08.2013
Quotation Deadline Time : 12:00

REQUEST for QUOTATION
 Transnet Capital Projects
RFQ Number / Date
 6000170284 / 12.08.2013
Contact Person / Telephone
 Eddie Quinn / 035 905 3664
Return to FAX Number/EMAIL
 0865150078 / TCPtendersRichardsBay@Transnet.net

Item	Material	Description	RFQ Qty	UoM	Required Del date	Confirm Del date	Unit Price Excl	Total Price Excl
00040		Turn Buckle 460mm Take Up as per Drg.CEE-TNB -19	4	ea	23.08.2013			
00050		Bow and Crosshead as per Drg. CEE -TNB 50	2	ea	23.08.2013			
00060		Parallel Clamp 160mm2 -100 / 80mm2 as per Drg. CEE -TNB 55(Supplied with inspection certificate)	50	ea	23.08.2013			
00070		Parallel Clamp 160mm2 -160mm2 as per Drg.CEE -TNB -55 (Supplied with inspection	50	ea	23.08.2013			

PREVIEW COPY ONLY



REQUEST FOR QUOTATION

Transnet SOC Limited
 T/A Transnet Capital Projects
 Company
 TFR Tender Board - JHB.
 TFR Tender Board
 Johannesburg.
 2000

Registration Number: 1990/000900/06
 Vat Number : 4720103177

Attention:
 TFR Official Tender Board.
 Telephone Number :
 Fax Number :
 Vendor Number :500000

Quotation Deadline Date : 19.08.2013
Quotation Deadline Time : 12:00

REQUEST for QUOTATION
 Transnet Capital Projects
RFQ Number / Date
 6000170284 / 12.08.2013
Contact Person / Telephone
 Eddie Quinn / 035 905 3664
Return to FAX Number/EMAIL
 0865150078 / TCPtendersRichardsBay@Transnet.net

Item	Material	Description	RFQ Qty	UoM	Required Del date	Confirm Del date	Unit Price Excl	Total Price Excl
		certificate)						
00080		Splice for 161mm2 CU Co	4	ea	23.08.2013			
		Splice for 161mm2 CU Contact wire as per Drg .CPE-TNB-21(Supplied with inspection certificate)						
00090		Steady Arm Attachment	12	ea	23.08.2013			
		Steady Arm Attachment as per Drg .BE-BU-29						
00100		Steady arm Socket as pe	40	ea	23.08.2013			
		Steady arm Socket as per Drg.TNB -76						
00110		Clamp Assembly -Dual pu	33	ea	23.09.2013			

PREVIEW COPY ONLY



REQUEST FOR QUOTATION

Transnet SOC Limited
 T/A Transnet Capital Projects
 Company
 TFR Tender Board - JHB.
 TFR Tender Board
 Johannesburg.
 2000

Registration Number: 1990/000900/06
 Vat Number : 4720103177

Attention:
 TFR Official Tender Board.
 Telephone Number :
 Fax Number :
 Vendor Number :500000

Quotation Deadline Date : 19.08.2013
Quotation Deadline Time : 12:00

REQUEST for QUOTATION
 Transnet Capital Projects
RFQ Number / Date
 6000170284 / 12.08.2013
Contact Person / Telephone
 Eddie Quinn / 035 905 3664
Return to FAX Number/EMAIL
 0865152978 / TCPtendersRichardsBay@Transnet.net

Item	Material	Description	RFQ Qty	UoM	Requested Del date	Confirm Del date	Unit Price Excl	Total Price Excl
		Clamp Assembly -Dual purpose as per Drg.CEE-TNB -5						
00120		Steady Arm as per Drg.	20	ea	23.08.2013			
		Steady Arm as per Drg. CEE -TND -19						
00130		Hockey Sticks as per Drg.	18	ea	23.08.2013			
		Hockey Sticks as per Drg.CEE-TNB -20						
00140		Attachments Fitting as	12	ea	23.08.2013			
		Attachments Fitting as per Drg.CEE-TNB 0071						
00150		Twisted 'H' as per Drg.	40	ea	23.08.2013			

PREVIEW COPY ONLY



REQUEST FOR QUOTATION

Transnet SOC Limited
 T/A Transnet Capital Projects
 Company
 TFR Tender Board - JHB.
 TFR Tender Board
 Johannesburg.
 2000

Registration Number: 1990/000900/06
 Vat Number : 4720103177

Attention:
 TFR Official Tender Board.
 Telephone Number :
 Fax Number :
 Vendor Number :500000

Quotation Deadline Date : 19.08.2013
Quotation Deadline Time : 12:00

REQUEST for QUOTATION
 Transnet Capital Projects
RFQ Number / Date
 6000170284 / 12.08.2013
Contact Person / Telephone
 Eddin Quinn / 035 905 3664
Return to FAX Number/EMAIL
 0865150078 / TCPtendersRichardsBay@Transnet.net

Item	Material	Description	RFQ Qty	UoM	Required Del date	Confirm Del date	Unit Price Excl	Total Price Excl
		Twisted 'H' as per Drg. CEE- TNB-60						
00160		Suspension Clamp as per	40	ea	23.08.2013			
		Suspension Clamp as per Drg. CEE -TNB-73						
00170		Clevis Socket PPO as per	20	ea	23.08.2013			
		Clevis Socket PPO as per Drg.CEE-TNB-40						
00180		Tower Hook as per Drg.C	40	ea	23.08.2013			
		Tower Hook as per Drg.CEE-TNB-41						
00190		Dropper Clip for 80mm s	2,000	ea	23.08.2013			

"PREVIEW COPY ONLY"



REQUEST FOR QUOTATION

Transnet SOC Limited
 T/A Transnet Capital Projects
 Company
 TFR Tender Board - JHB.
 TFR Tender Board
 Johannesburg.
 2000

Registration Number: 1990/000900/06
 Vat Number : 4720103177

Attention:
 TFR Official Tender Board.
 Telephone Number :
 Fax Number :
 Vendor Number :500000

Quotation Deadline Date : 19.08.2013
Quotation Deadline Time : 12:00

REQUEST for QUOTATION
 Transnet Capital Projects
RFQ Number / Date
 6000170284 / 12.08.2013
Contact Person / Telephone
 Eddie Quinn / 035 905 3664
Return to FAX Number/EMAIL
 0865150078 / TCPtendersRichardsBay@Transnet.net

Item	Material	Description	RFQ Qty	UoM	Requested Del date	Confirm Del date	Unit Price Excl	Total Price Excl
		Dropper Clip for 80mm sq.catenary as per Drg.CEE-TND-36						
00200		Dropper Clip for 80mm s	2,000	ea	23.08.2013			
		Dropper Clip for 80mm sq. catenary as per Drg.CEE-TND-36						
00210		Dropper Clip 161mm2 sq	450	ea	23.08.2013			
		Dropper Clip 161mm2 sq contact as per Drg. CEE -TND 22						
00220		Swivel Clip for 161mm2	40	ea	23.08.2013			
		Swivel Clip for 161mm2 contact wire as per Drg.CEE-TND -35						
00230		Earth wire Clamp for 50	50	ea	23.08.2013			

PREVIEW COPY ONLY



REQUEST FOR QUOTATION

Transnet SOC Limited
 T/A Transnet Capital Projects
 Company
 TFR Tender Board - JHB.
 TFR Tender Board
 Johannesburg.
 2000

Registration Number: 1990/000900/06
 Vat Number : 4720103177

Attention:
 TFR Official Tender Board.
 Telephone Number :
 Fax Number :
 Vendor Number :500000

Quotation Deadline Date : 19.08.2013
Quotation Deadline Time : 12:00

REQUEST for QUOTATION
 Transnet Capital Projects
RFQ Number / Date
 6000170284 / 12.08.2013
Contact Person / Telephone
 Eddie Quinn / 035 905 3664
Return to FAX Number/EMAIL
 0865150078 / TCPtendersRichardsBay@Transnet.net

Item	Material	Description	RFQ Qty	UoM	Required Del date	Confirm Del date	Unit Price Excl	Total Price Excl
		Earth wire Clamp for 50mm2 ACSR wire as per Drg. CEE-TN-371 (supplied with inspection certificate)						
00240		Feeder clamp 161mm2 -16	50	ea	23.08.2013			
		Feeder clamp 161mm2 -160mm2 as per Drg.CEE- TNB-57(supplied with inspection certificate)						
00250		Dropper Sleeve / Ferrule	1,000	ea	23.08.2013			
		Dropper Sleeve / Ferrule as per Drg.CEE-TX -79						
00260		Wire Ending Cone for 16	2	ea	23.08.2013			
		Wire Ending Cone for 161mm2 CU Contact wire as per Drg. CEE-TNB 36 (supplied with inspection certificate)						

PREVIEW COPY

Transnet Limited t/a Transnet Freight Rail (R.M.E.) # Richards Bay, hereby invite your company to submit a detailed quotation for:



REQUEST FOR QUOTATION

Transnet SOC Limited
T/A Transnet Capital Projects
 Company
 TFR Tender Board - JHB.
 TFR Tender Board
 Johannesburg.
 2000

Registration Number: 1990/000900/06
Vat Number : 4720103177

Attention:
 TFR Official Tender Board.
 Telephone Number :
 Fax Number :
 Vendor Number :500000

Quotation Deadline Date : 19.08.2013
Quotation Deadline Time : 12:00

REQUEST for QUOTATION
 Transnet Capital Projects
RFQ Number / Date
 6000170284 / 12.08.2013
Contact Person / Telephone
 Eddie Quinn / 035 905 3664
Return to FAX Number/EMAIL
 0865159978 / TCPtendersRichardsBay@Transnet.net

Item	Material	Description	RFQ Qty	UoM	Required Del date	Confirm Del date	Unit Price Excl	Total Price Excl
------	----------	-------------	---------	-----	-------------------	------------------	-----------------	------------------

The Supply, Deliver and Offload of Various OHTE Items, as mentioned above, and to Transnet Specifications & Drawings, delivered to 1 Morris Road - Empangeni Rail - Old Goods Shed.

All technical queries relating to this invitation may be addressed to;
 Mr. Pierre Crocker Tel: 083 279 0437 / 035-905 3638.

All tender related queries pertaining to this invitation may be addressed to;
 Mr. Eddie Quinn, Tel: 035 # 905 3664.

The closing time for receipt of your official quotations is 12:00 hours on Monday, 19 August 2013.

Telephonic and late quotes will not be accepted.
 All quotations should be clearly marked, and may be dropped in our tender box, or alternatively forwarded to:
 Me Qetelo Moshoeshoe, Tender & Fax Assistant,
 Fax No: 086 515 9978 or 031-830 0000, and
 e-mailed to: TCPtendersRichardsBay@transnet.net

Physical address for delivering quotations, if required, is:

Transnet Capital Projects Richards Bay
 Tender Box in Main Foyer
 Old Naval Base,
 Commodores Close,



REQUEST FOR QUOTATION

Transnet SOC Limited
 T/A Transnet Capital Projects
 Company
 TFR Tender Board - JHB.
 TFR Tender Board
 Johannesburg.
 2000

Registration Number: 1990/000900/06
 Vat Number : 4720103177

Attention:
 TFR Official Tender Board.
 Telephone Number :
 Fax Number :
 Vendor Number :500000

Quotation Deadline Date : 19.08.2013
Quotation Deadline Time : 12:00

REQUEST for QUOTATION
 Transnet Capital Projects
RFQ Number / Date
 6000170284 / 12.08.2013
Contact Person / Telephone
 Eddie Quinn / 035 905 3664
Return to FAX Number/EMAIL
 0865139978 / TCPtendersRichardsBay@Transnet.net

Item	Material	Description	RFQ Qty	UoM	Required Del date	Confirm Del date	Unit Price Excl	Total Price Excl
------	----------	-------------	---------	-----	-------------------	------------------	-----------------	------------------

Meerensee,

The contractor's address and identification details have to be shown on each quotation submitted.

Please supply the following documents with your quotation submitted;

- Valid Tax Clearance certificate.
- Copy of your latest B.B.B.E.E. Certificate.
- Certificate of good standing with the Workman's Compensation Commissioner.
- Test Certificate for item required.

Failing to submit any of the documents mentioned above, could result in your quotation to be disqualified / not accepted.

Note: #Transnet may not necessarily accept the lowest or any other offer and reserves the right to select in its favor any or, a portion of any offer made"

If you are unable to quote for this RFQ, please submit a NO QUOTE, with a short reasons, if possible, for not being able to quote.

Otherwise we look forward to receive your detailed quote by the date and time stated.

Yours faithfully,

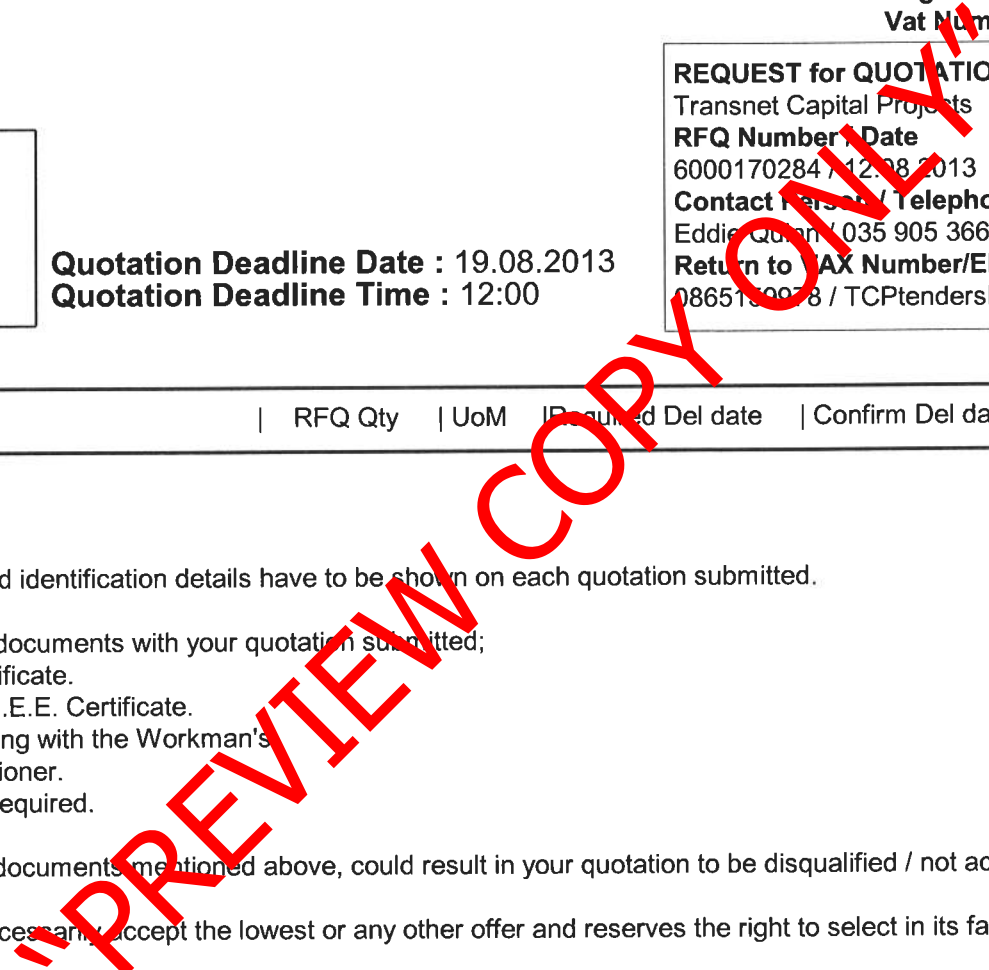



REQUEST FOR QUOTATION

Transnet SOC Limited
T/A Transnet Capital Projects
 Company
 TFR Tender Board - JHB.
 TFR Tender Board
 Johannesburg.
 2000

Registration Number: 1990/000900/06
Vat Number : 4720103177

Attention:
 TFR Official Tender Board.
 Telephone Number :
 Fax Number :
 Vendor Number :500000

Quotation Deadline Date : 19.08.2013
Quotation Deadline Time : 12:00

REQUEST for QUOTATION
 Transnet Capital Projects
RFQ Number / Date
 6000170284 / 12.08.2013
Contact Person / Telephone
 Eddie Quinn / 035 905 3664
Return to FAX Number/EMAIL
 0865130078 / TCPtendersRichardsBay@Transnet.net

Delivery Address

For: TFR (RME) Richards Bay.
 1 Morris road - Jan Ayres 083 263 0845
 Mr Pierre Crocker - Tel: 083 279 0437.
 3900

This RFQ is subject to the following conditions:

1. Price/s : The price/s quoted in SA currency and is excluding of V.A.T
2. Delivery : The price/s quoted should include delivery cost to the delivery address stated on the RFQ
3. Returnables : A valid tax clearance certificate and BBBEE certificate from a SANAS accredited verification agency attached to quotation for all quotes above R30 000.
 Please note that only the official Transnet RFQ will be accepted and all other correspondence to be attached to the original
4. Safety : To confirm to Transnet Capital Projects Health & Safety plan and specification; HAS-std-0001, copy available on request.
5. Confirmation: To confirm your participation in this tender process please sign and return this document as immediate effect prior to the quotation deadline.
6. Negotiations: The Employer may elect to negotiate the final terms of the contract/order with the preferred tenderer in accordance with Clauses F.2.17 and F.3.13 of the CIDB Standard Conditions of Tender. A copy of which is available upon request.

Signature _____

Date _____

"PREVIEW COPY ONLY"

REV: 10332972

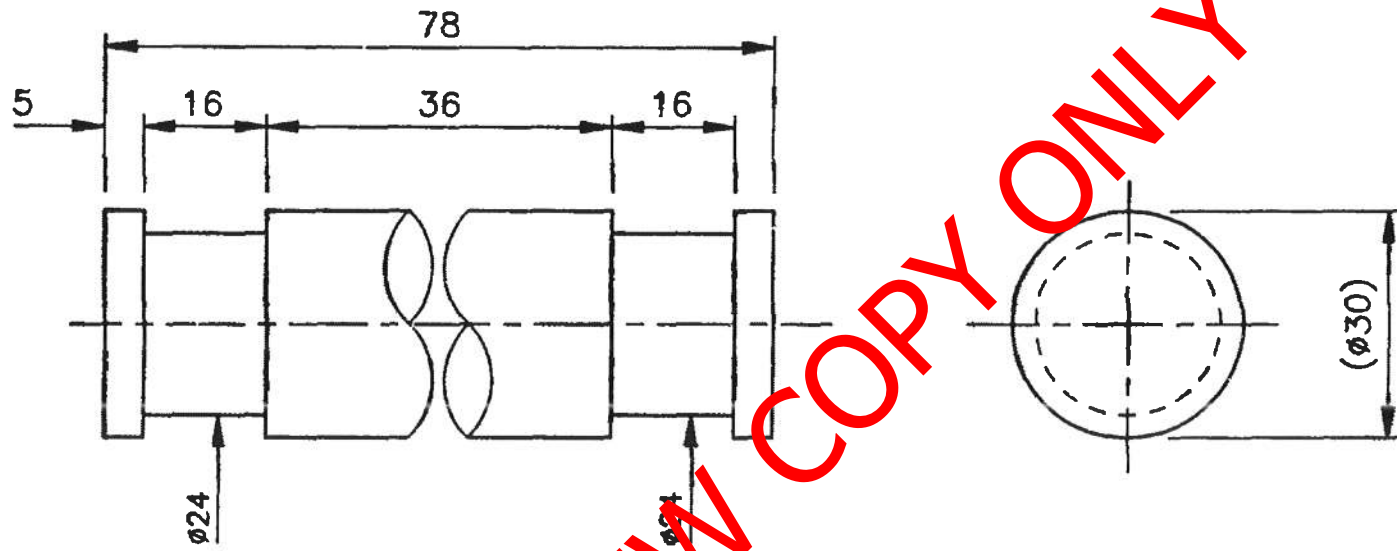

FINISH
 1. MACHINE THUS ∇
 2. ZINC COAT TO SPEC SABS 763 FOR CONDITIONS IN SITU.

AMENDMENTS		
NO	NAME	DATE
1	J HARCUS	95-08-21

REDRAWN. DRG NO WAS TMHB-8.
DO REF T95/050

"PREVIEW COPY ONLY"

DIMENSIONS: mm
SCALE: 1:1

MATERIAL: ITEM NO 11/002816 STEEL, ROUND, $\phi 30$ X 80 LG

DO REF: T79/20	GEN TOL: LIN \pm 1	ANG \pm -
DRN: B v d WEST	CKD: J SWIEGERS	DATE: 80-07-28
ENG: -	GA WILLIAMS for CHIEF ENG	

PIN
STAY WIRE

INFRASTRUCTURE
(ELECTRICAL)

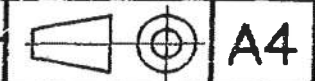

DRG NO CEE-
TNE-31
SHT 3 OF 3

TC000937

Q52. 10332971

ITEM	DESCRIPTION	QTY	STORES ITEM NO	DRG NO CEE-	AMENDMENTS		
1	PIN, STRAIGHT, HEADED, MILD STEEL, $\phi 24$ *	1	1/---	---	NO	NAME	DATE
2	PIN, COTTER, BRASS, $\phi 6,3 \times 36$ LG	1	54/3795	---	3	JVT	97-09-05

DRAWING REVISED.
DO REF: T96/021

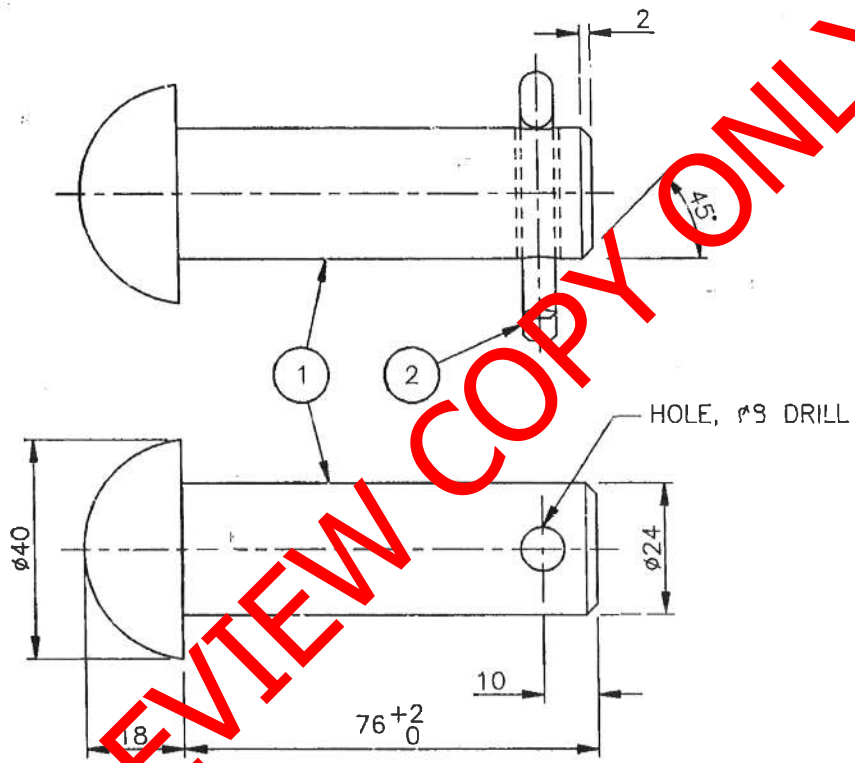

"PREVIEW COPY ONLY"

* FINISH
ZINK COAT ITEM 1 TO SABS 763 FOR CONDITIONS IN SITU.

DO REF: C227/68	GEN TOL: LIN \pm 0,5	ANG \pm 1'
DRN: M.K.	CKD: F.W.C.	DATE: 69-04-18
ENG: R.C.K.	W ROGERS	for CHIEF ENG

PIN, STRAIGHT, HEADED, $\phi 24 \times 76$ LG
COMPLETE WITH COTTER PIN.

INFRASTRUCTURE (ELECTRICAL) SPOORNET

STORES ITEM NO 54/4007
DIMENSIONS: mm SCALE: 1:1
A3
DRAWING NO CEE- TX-59
SHEET — OF —

Req: 10332970

ITEM	DESCRIPTION	QTY	STORES ITEM NO	DRG NO CEE-	AMENDMENTS
1	RIVET, STEEL, SNAP HEAD, $\phi 16$ x 60 LG	1	01/22722	---	NO NAME DATE
2	LOCKING SPLIT PIN	1	54/3734	TX-54	3 J v DYK 94/8/4

DIMENSION 50 WAS 46. TOL REVISED. ITEM 1 STORES ITEM NO WAS 01/22710. DO REF T94/046

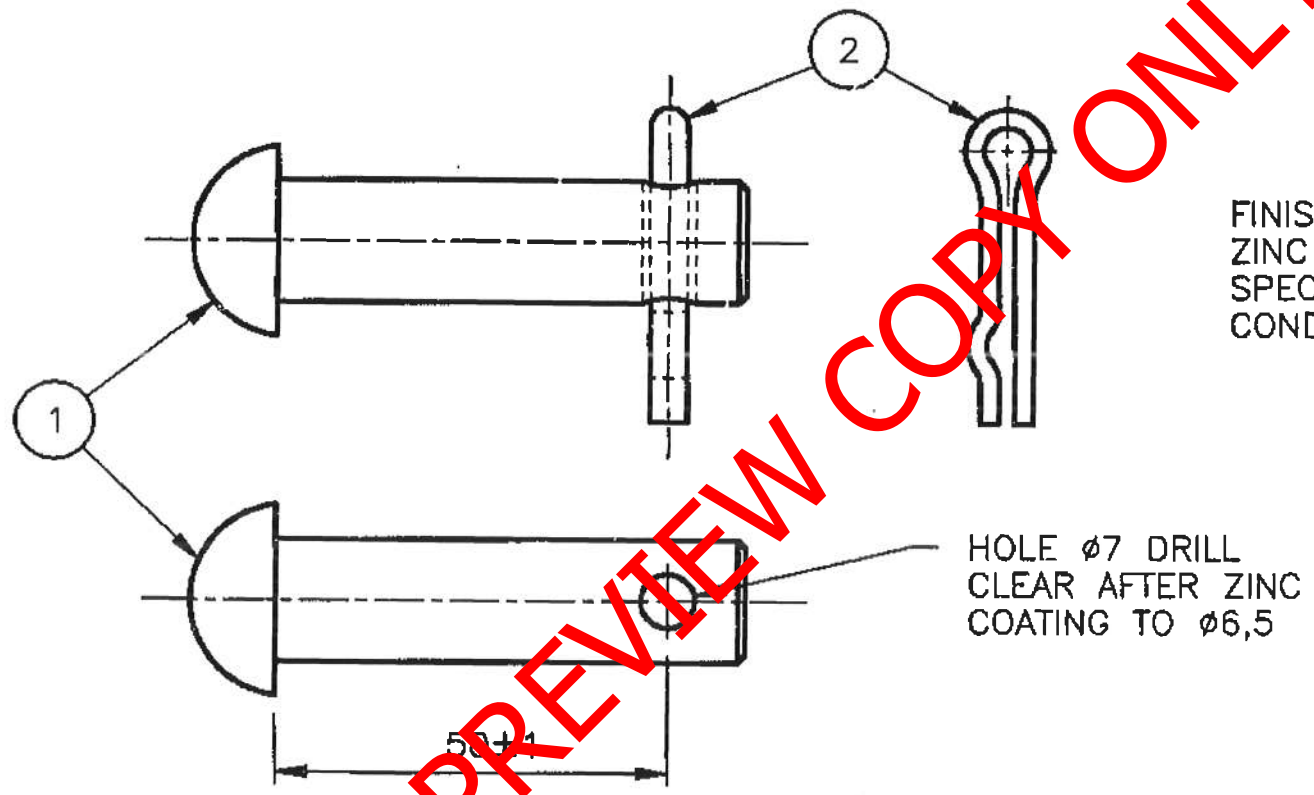

FINISH
ZINC COAT ITEM 1 TO
SPEC SABS 763 FOR
CONDITIONS IN SITU.

HOLE $\phi 7$ DRILL
CLEAR AFTER ZINC
COATING TO $\phi 6,5$

STORES ITEM NO.
54/4020

DIMENSIONS: mm
SCALE: 1:1

A4

DO REF: C84/70	GEN TOL: LIN $\pm 0,5$	ANG \pm —
DRN: G.J. v G.	CKD: I.T.	DATE: 70-09-09
ENG: —	T.C. BROOK	for CHIEF ENG

PIN, STRAIGHT, HEADED, $\phi 16$
WITH LOCKING SPLIT PIN

INFRASTRUCTURE
(ELECTRICAL)



DRG NO CEE-
TX-66

SHT — OF —

T0000639

Rev: 1333029

ITEM	DESCRIPTION	QTY	STORES ITEM NO	DRG NO CEE-	AMENDMENTS		
					NO	NAME	DATE
1	SWIVEL FITTING, KNUCKLE OR STEADY ARM	1		TND-1			
2	CHEEK, 161mm ² Cu. CONTACT WIRE SWIVEL CLAMP	2	54/33583	TN-330	1	JVT	97-11-24
3	BOLT, HEX. HEAD, M10 x 20L Cu-Ni-Si TO SPEC. CEE.0063 (SEE NOTE)	2	54/3645		REDRAWN. DRG NO WAS CEE-TN-366.		
4	LOCK WASHER, INTERNAL TOOTH TYPE, M10 PHOSPHOR BRONZE (SEE NOTE)	2	54/2688		DO REF T95/067		
5	BOLT, HEX. HEAD, M10 x 35L Cu-Ni-Si TO SPEC. CEE.0063 (SEE NOTE)	2	54/3151				
6	CHEEK, 107mm ² Cu. CONTACT WIRE SWIVEL CLAMP	2	54/28819	TND-37	2		2003/11/26

REVISED. ITEM 6 ADDED AND SUB-TITLE CHANGED.
ECP REF: 2003-091
DO REF: CDO/2883

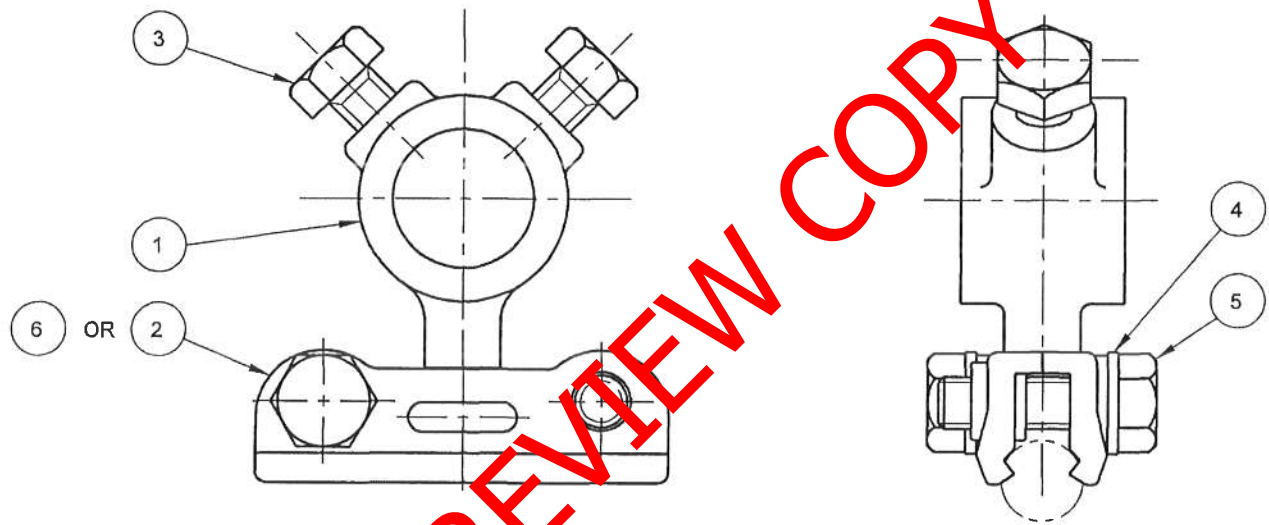

NOTE
ITEMS 3,4 & 5: FOR ALTERNATIVE MATERIAL USE STAINLESS STEEL TO SPEC. AISI GR 304.

STORES ITEM NO
54/690

DIMENSIONS: mm
SCALE: 1:1

A3

DO REF: M118/70	GEN TOL: LIN±	ANG±
DRN: DW	CKD: G W MALONE	DATE: 70-11-19
ENG: PIENAAR	for CHIEF ENG	

SWIVEL TYPE CONTACT WIRE CLAMP ASSEMBLY

161mm² Cu OR 107mm² CONTACT WIRE KNUCKLE OR STEADY ARM

DRAWING NO **CEE-TND-35**
SHEET - OF -

Rev: 10333025

ITEM	DESCRIPTION	QTY	STORES ITEM NO	DRG NO CEE-	AMENDMENTS		
1	CLAMP, ELECTRICAL, HALF DROPPER CLIP WITH THREAD AND SPACER PIN	1	-----	TND-22 SHT 2	NO	NAME	DATE
2	CLAMP, ELECTRICAL, HALF DROPPER CLIP WITHOUT THREAD	1	-----	TND-22 SHT 3	1	W BRIGHT	93-05-28
3	SCREW, CHEESE HEAD, STAINLESS STEEL TO SPEC AISI GR 304	1	-----	-----	REINSTATED AND REDRAWN. DRG NO WAS CEE- TN-436 SHT 1. D O REF T93/003		
4	WASHER, LOCKING, INTERNAL TOOTH, STAINLESS STEEL TO SPEC AISI GR 304, M10	1	-----	-----			

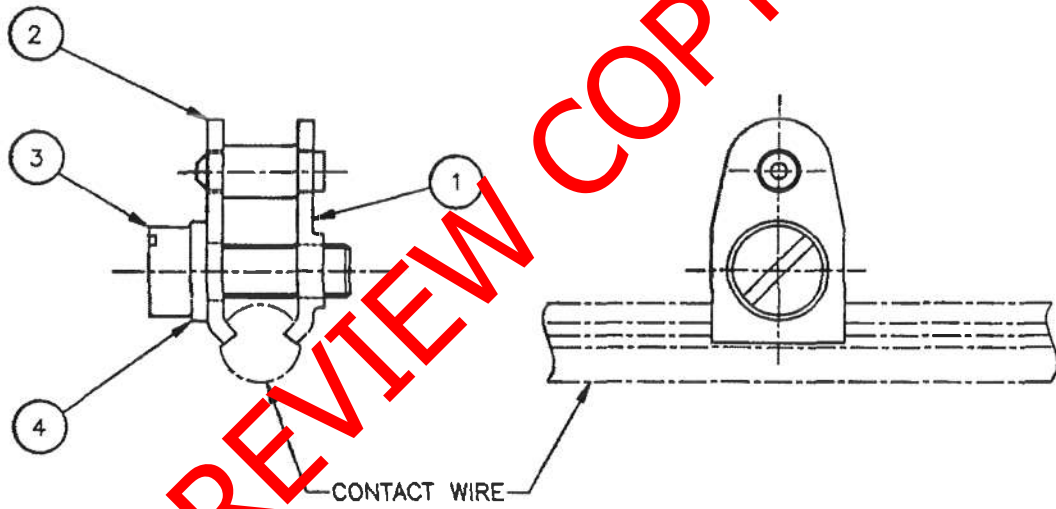

TABLE (SEE SHEET 5)	
CONTACT WIRE	STORES NO
161mm ² Cu	54/17312
107mm ² Cu	54/6787

2 LO BORCHARD 95-06-22
STORES ITEM NO. WAS 54/527.
DO REF T95/037
3 JSA HARCUS 97-11-21
TABLE ADDED TITLE CHANGED.
DO REF T97/013

STORES ITEM NO SEE TABLE
DIMENSIONS: mm
SCALE: 1:1

A3
DRAWING NO CEE-
TND-22
SHEET 1 OF 5

DO REF: N41/70 GEN TOL: LIN± - ANG± -
DRN: H F CKD: H NIENHAUS DATE: 70-05-04
ENG: PIENAAR PHILLIPS for CHIEF ENG
INFRASTRUCTURE (ELECTRICAL) SPOORNET

CLAMP, ELECTRICAL
DROPPER CLIP, COMPLETE, 161mm/107mm SQUARE Cu CONTACT WIRE
KARL PHISTERER / ARTHUR FLURY SECTION INSULATOR

Req: 10333027

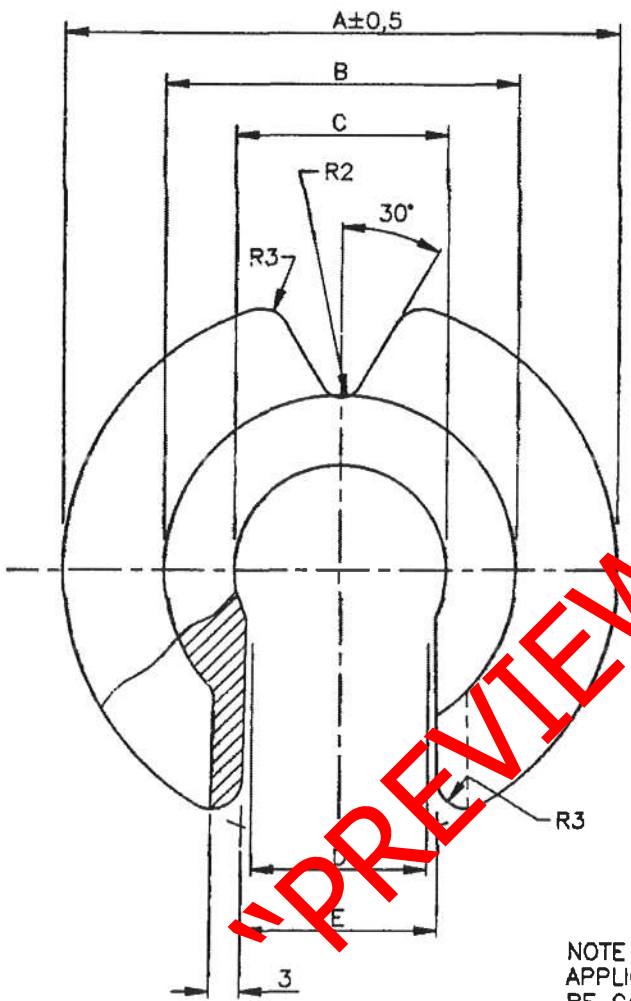

CATENARY	A	B	C	D	E	ITEM NO
80mm ²	∅38	∅15	∅10,8	9,6	9 ⁺¹ ₀	54/6840
100mm ²	∅40	∅20,1	∅12,1	10,7	10 ⁺¹ ₀	54/16861
* 160mm ²	∅46,5	∅26,4	∅15,5	14,1	13 ⁺² ₀	54/16836
250mm ²	∅54	∅33,9	∅20,5	18,2	16 ⁺³ ₀	54/16848
** 530mm ²	∅68	∅48,4	∅27,4	26	25 ⁺⁴ ₀	54/31701

* ALSO FOR CONDUCTOR (ACSR) CODE NAME "TIGER"
 ** FOR CONDUCTOR (ACSX) CODE NAME "DEER"

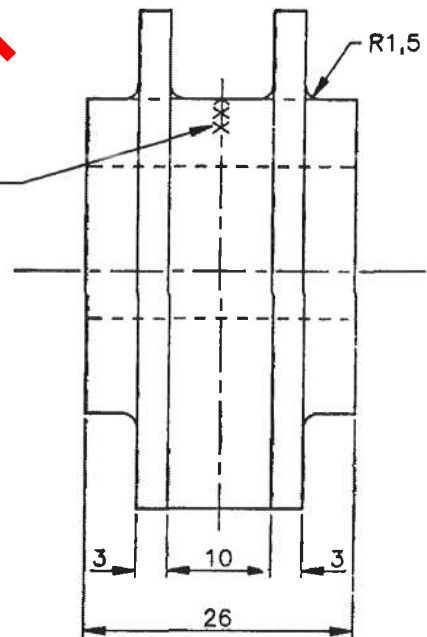

NOTE
 APPLICABLE CONDUCTOR SIZE 80-, 100-, 160-, 250- OR 530mm² TO BE CAST OR PUNCHED IN POSITION SHOWN (3mm CHARACTER HEIGHT).

AMENDMENTS		
NO	NAME	DATE
1	I DE VILLIERS	90-02-14
REDRAWN, INFORMATION ADDED. DO REF: T90/009		
2	I DE VILLIERS	91-03-04
INDICATION OF CONDUCTOR SIZE MOVED. DO REF: T91/010		
3	W BRIGHT	92-06-22
DIMENSION "E" WAS 10,1 ; 11,3 ; 14,8 AND 19. DO REF: T92/027		
4	H A SLIER	98-06-04
DRAWING REVISED AND INFORMATION ADDED. DO REF: T98/024		

PREVIEW COPY ONLY

MATERIAL: NYLON 66, PIGMENT: BLACK		
DO REF T90/001	GEN TOL: LIN ± 0,2	ANG ± 0°30'
DRN J VON ABO	CKD J H SWIEGERS	DATE 90-01-29
ENG A VERSTEEG	A VERSTEEG	for CHIEF ENG

DROPPER CLIP
 CLIP-ON TYPE
 80-, 100-, 160-, 250- & 530mm² CATENARIES

DIMENSIONS: mm SCALE 2:1		A3
DRAWING NO CEE- TND-5		
SHEET - OF -		

Rev: 10233026

ITEM	DESCRIPTION	QTY	STORES NO	STORES NO	AMENDMENTS		
1	Cu-Nu-Si 25 x 3 ALLOY x 54 LG	1			NO	NAME	DATE
2	Cu-Nu-Si 25 x 3 ALLOY x 54 LG	1			1	JVT	97-04-07
3	Cu-Ni-Si MACHINE SCREW ALLOY SLOTTED CSK HEAD (SPEC CEE.0063) M8-6g x 20LG	1	54/3608		REVISED, DRG NO WAS CEE-TN-294. DO REF: T96/001		

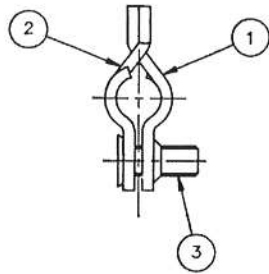

ASSEMBLY

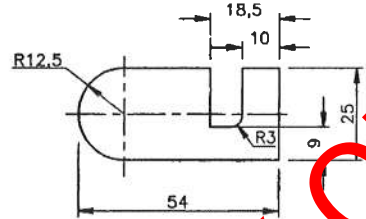

DEVELOPED VIEW ITEM 1 & 2

NOTES:

1. DRAW THROUGH FOR INCREASED LENGTH OF THREAD.
2. TO BE READ IN CONJUNCTION WITH SPECIFICATION NO. CEE.0063.
3. ALTERNATIVE MATERIAL: STAINLESS STEEL TO SPEC AISI GR 304.

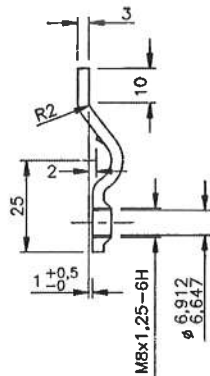

ITEM 1

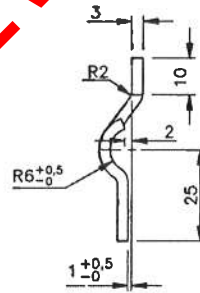
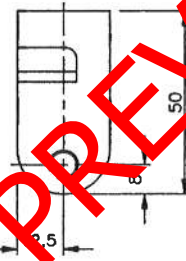

ITEM 2

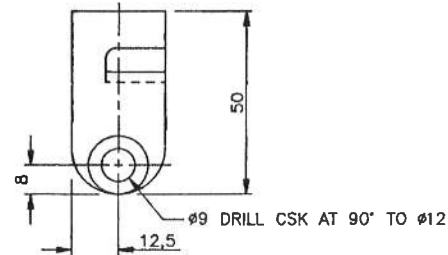

"PREVIEW COPY ONLY"

STORES ITEM NO	54/552
DIMENSIONS:	mm
SCALE:	1:1
A2	
DRAWING NO	CEE-TND-36
SHEET	OF

DO REF: N41/70	GEN TOL: LIN± 0,5	ANG± 1°
DRN: NWL	CKD: HN	DATE: 70-05-04
ENG: F PIENAAR	W PHILLIPS for CHIEF ENG	
INFRASTRUCTURE (ELECTRICAL)		

CLAMP ELECTRICAL: (DROPPER CLIP)
CATENARY 80 mm² AND 100 mm²

0000130

Rea: 10233025

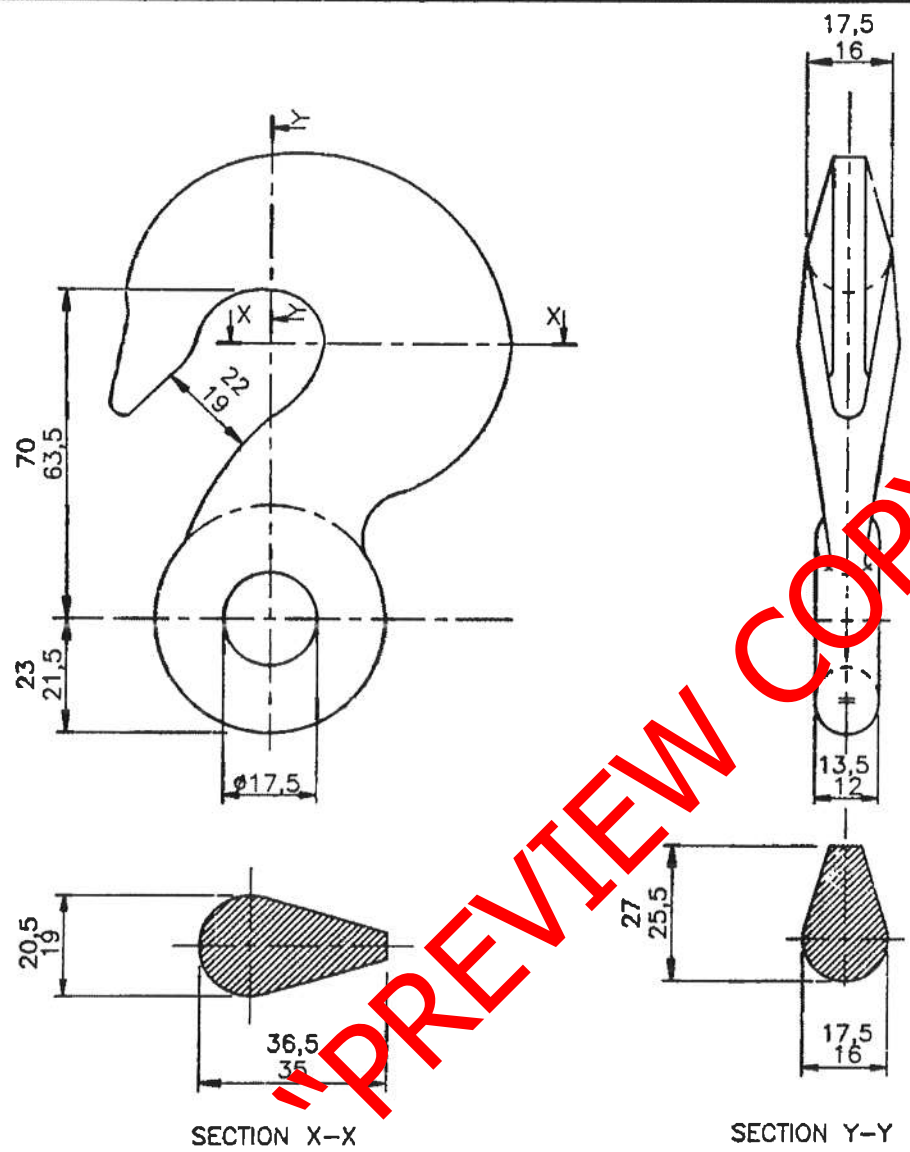

- NOTES
- MECHANICAL STRENGTH 44.5kN.
 - THE FOLLOWING PERMANENT MARKINGS MUST APPEAR ON THIS ARTICLE:
 - SPOORNET
 - MAKER'S IDENTIFICATION
 - BATCH NUMBER.
 - ZINC COAT TO SPEC SABS 763 FOR CONDITIONS IN SITU.

AMENDMENTS		
NO	NAME	DATE
1	JVT	95-09-11

REVISED, DRG NO WAS CEE-TN-361.
DO REF: T95/051

STORES ITEM NO _____

DIMENSION: mm
SCALE: 1:1

A3

DRAWING NO CEE-TNB-41
SHEET - OF -

MATERIAL: ITEM NO _____ SPHEROIDAL GRAPHITE IRON TO SPEC SABS 936 GRADE SG 50

DO REF: J71/228 GEN TOL: LIN± 0,5 ANG± 1°

DRN: C. S. CKD: _____ DATE: 62-06-13

ENG: _____ W PHILLIPS for CHIEF ENG

TOWER HOOK

INFRASTRUCTURE
(ELECTRICAL)



10000971

Rev: 1033324

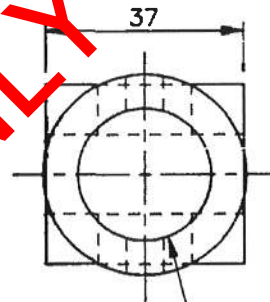
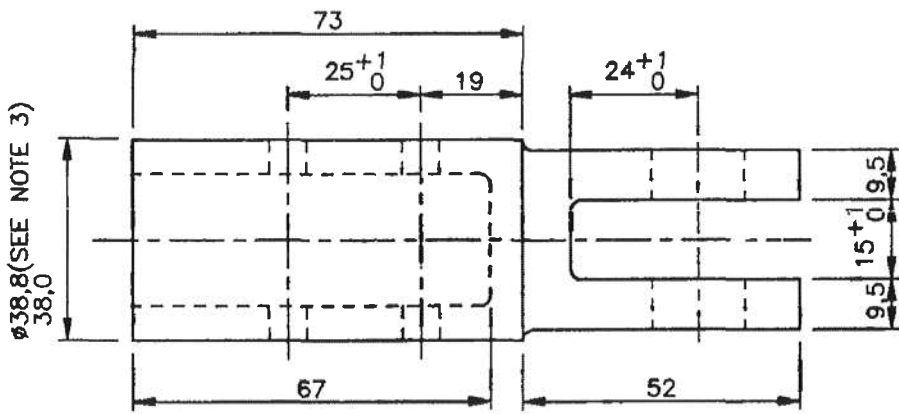

- NOTES
1. SHOULD FITTING BE CORED THEN WALL THICKNESS MUST NOT BE LESS THAN 6,5.
 2. O. D. MUST BE TO DIMENSION SHOWN AFTER COATING.
 3. THE FOLLOWING PERMANENT MARKINGS MUST APPEAR ON THIS ARTICLE:
a) SPOORNET b) MAKER'S IDENTIFICATION
c) BATCH NUMBER.
 4. ZINC COAT TO SABS 763 FOR CONDITIONS IN SITU.

AMENDMENTS		
NO	NAME	DATE
1	JVT	95-09-11

REVISED, DRG NO WAS CEE-TN-408.
DO REF: T95/051

MATERIAL: SPHEROIDAL GRAPHITE IRON TO SPEC SABS 936 GRADE SG 50

DO REF: J71/228 GEN TOL: LIN ± 1,0 ANG ± —
 DRN: J.V.S. CKD: — DATE: 56-10-22
 ENG: F. P. W. LEHMAN for CHIEF ENG

CLEVIS SOCKET
PUSH-PULL-OFF TUBE

INFRASTRUCTURE (ELECTRICAL) SPOORNET

STORES ITEM NO
54/1420
DIMENSION: mm
SCALE: 1:1

A3
DRAWING NO CEE-
TNB-40
SHEET - OF -

"PREVIEW COPY ONLY"

T0000963

Req: 10233023

ITEM	DESCRIPTION	QTY	STORE ITEM NO.	DRG NO CEE-	AMENDMENTS		
					NO	NAME	DATE
1	CLEVIS PIN $\phi 16$	1	54/4020	TX-66	1	JVT	97-07-04
2	CLAMP BODY WITH TIE DOWN FACILITY	1		TNB-73 SHT 2	REVISED. DRG NO. WAS TN-349 SHT 1.		
3	SADDLE	1		TNB-72 SHT 3	DO REF: T96/001		
4	STRAP	2		TNB-72 SHT 4	2 HA SLIER 98-02-25		
5	BOLT AND NUT M12	4		TX-68	ITEM 7 AND NOTE 2 ADDED.		
6	WASHER, STEEL, LOCK, SINGLE COIL SQ SECTION, GALV, M12	4	1/33850		DO REF: T98/011		
7	LOWER LINER, 162mm ² ACSR CATENARY WIRE (SEE NOTE 2)	1		TNB-89			

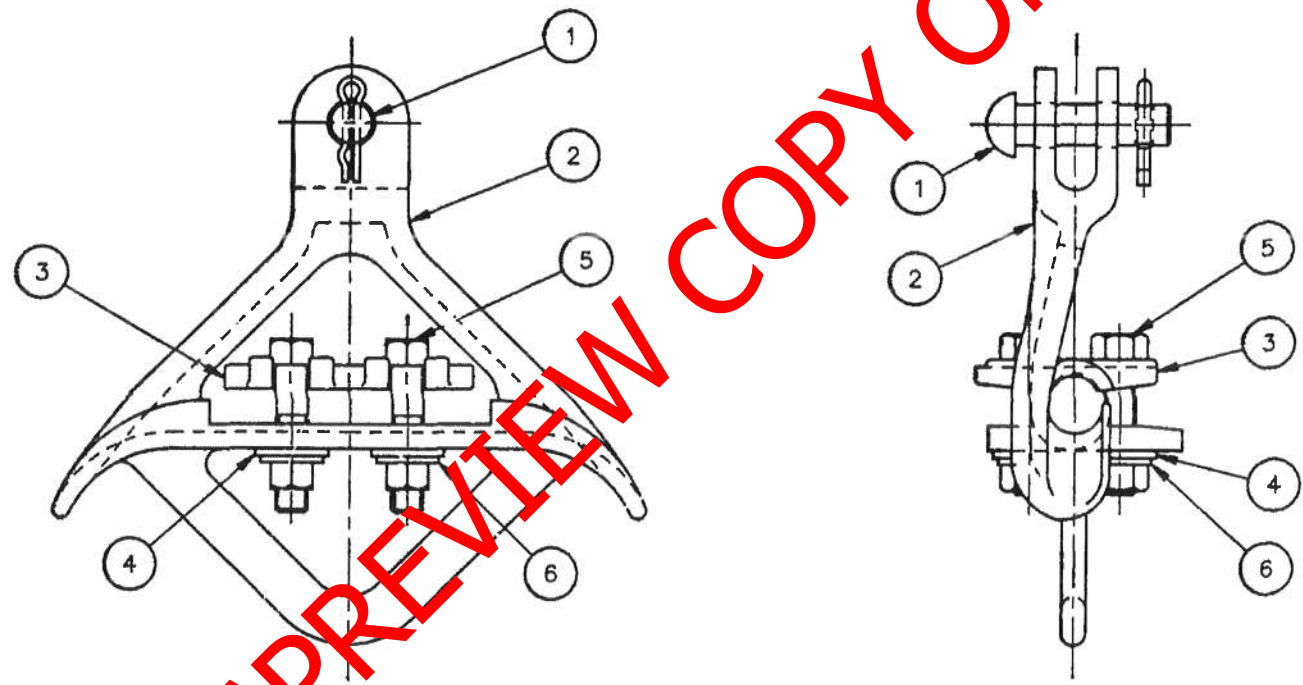

"PREVIEW COPY ONLY"

NOTES
 1. MECHANICAL STRENGTH WITH VERTICAL LOAD 44,5kN, SLIPPING LOAD 13,3kN.
 2. USE ITEM 7 WHEN THIS CLAMP IS USED FOR THE 162mm² ACSR (TIGER) CATENARY.

DIMENSIONS: mm
 SCALE: 1:2

DO REF: N74/68	GEN TOL: LIN \pm 1,0	ANG \pm 1'
DRN: WJN	CKD: HN	DATE: 68-05-20
ENG: J SAMUEL	W PHILLIPS	for CHIEF ENG

SUSPENSION CLAMP

CLEVIS TYPE WITH TIE DOWN FACILITY

A3
 DRAWING NO CEE-
TNB-73
 SHEET 1 OF 2

Rev: 10233022

AMENDMENTS		
NO	NAME	DATE
1	JVT	97-04-07

REVISED, DRG NO WAS CEE-TN-351.
DO REF: T96/001

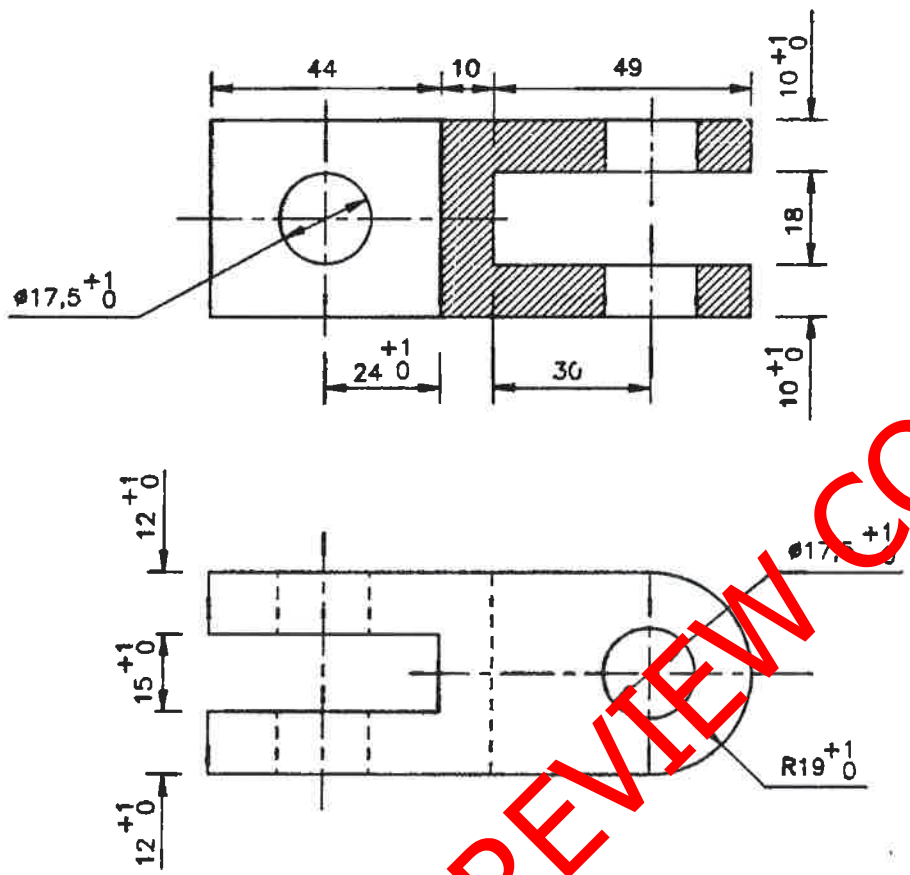

"PREVIEW COPY ONLY"

NOTES

- MECHANICAL STRENGTH 44,5KN.
- OTHER SUITABLE MATERIAL MAY BE OFFERED BY TENDER FOR CONSIDERATION. THIS ITEM IS USED ON OVERHEAD TRACK EQUIPMENT AND MUST BE CORROSIVE RESISTANT.
- THE FOLLOWING PERMANENT MARKINGS MUST APPEAR ON THIS ARTICLE:
 - SPOORNET.
 - MAKER'S IDENTIFICATION.
 - BATCH NUMBER.
- FINISH: ZINC COAT TO SABS 763 FOR CONDITIOS IN SITU.

MATERIAL: SPHEROIDAL GRAPHITE IRON TO SPEC SABS 936 GRADE SG 50

DO REF: C227/68 GEN TOL: LIN ± 1 ANG \pm —

DRN: P L W CKD: — DATE: 80-02-13

ENG: K L K TC BROOK for CHIEF ENG

CLEVIS FITTING

TWISTED 'H'

STORES ITEM NO
54/1521

DIMENSIONS: mm
SCALE: 1:2

A3

DRAWING NO CEE-
TNB-60

SHEET — OF —

INFRASTRUCTURE
(ELECTRICAL)



Rev: 10333006

ITEM	DESCRIPTION	QTY	STORES ITEM NO	DRG NO CEE-	AMENDMENTS
1	CHEEK	2	—————	TNB-22	NO NAME DATE
2	LOCKING PLATE	2	—————	TNB-23	1 W BRIGHT 94-08-18
3	BOLT, HEX HEAD, Cu-Ni-Si OR STAINLESS STEEL, M12 X 35L, TO SPEC AISI GR 304.	8	54/3670	—————	REDRAWN. DRG NO WAS CEE-TN-387 AND ITEM 1: DRG NO CEE-TN-355 REMOVED. DO REF: T93/055

REDRAWN. DRG NO WAS CEE-TN-387 AND ITEM 1: DRG NO CEE-TN-355 REMOVED.
DO REF: T93/055

NO	NAME	DATE
2	<i>[Signature]</i>	27/05/2002

EXTENDED CHEEKS SHOWN. ITEM 3 WAS QTY 6
CP REF. 2002027
DO REF. CDO/1876

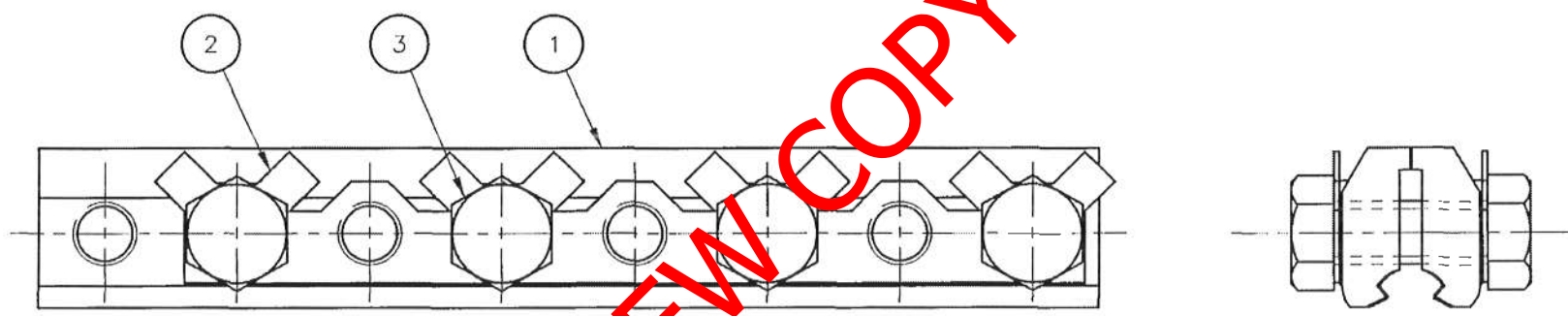

"PREVIEW COPY ONLY"

STORES ITEM NO
54/754

DIMENSION: mm
SCALE: 1:1

A3

DO REF: J71/212 GEN TOL: LIN± ——— ANG± ———
DRN: P O'GORMAN CKD: A LOTTERING DATE: 85-06-13
ENG: JD KRUGER JD KRUGER for CHIEF ENG

CENTRAL DRAWING OFFICE SPOORNET

SPLICE, CONDUCTOR
161mm² Cu CONTACT WIRE

DRAWING NO CEE-
TNB-21
SHEET — OF —

T0000625

Rev: 10233 004 / 5

STORES ITEM NO	CONDUCTOR SIZES
54/000766	100mm ² / 80mm ² - 50mm ²
54/000791	100mm ² / 80mm ² - 100mm ² / 80mm ²
54/002728	160mm ² - 50mm ²
54/002753	160mm ² - 100mm ² / 80mm ²
54/002777	160mm ² - 160mm ²
54/000843	250mm ² - 50mm ²
54/000867	250mm ² - 100mm ² / 80mm ²
54/000880	250mm ² - 160mm ²
54/000907	250mm ² - 250mm ²

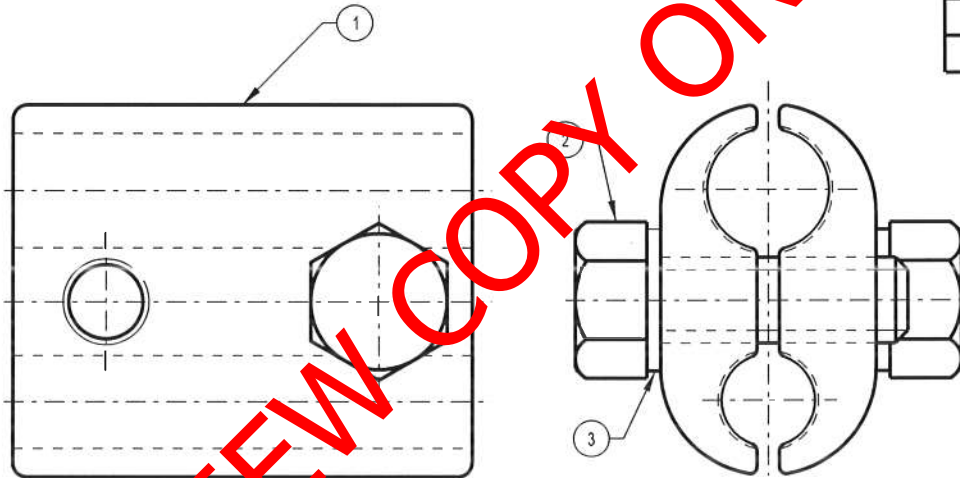

"PREVIEW COPY ONLY"

NOTE
Use Item 4 on the 250mm² side when this clamp is used for the 162mm² ACSR (Tiger) Catenary.

Item 3 Alternative material: Stainless steel to Specification AISI Grade 304.

ITEM NO	DESCRIPTION	QTY	STORES ITEM NO	DRAWING NO
4	Conductor splice liner, 162mm ² ACSR Catenary Wire (See Note)	2	-	CEE-TNB-0090
3	Washer, Lock, Phosphor Bronze, Internally Toothed, M12 to Specification BS.407.	2	54/002704	-
2	Screw, Machine, Cu-Ni-Si, Hex. Head, M12 x 6g - 35L to Specification CEE-0063.	2	54/003670	-
1	Parallel half clamp.	2	-	CEE-TNB-0054

© COPYRIGHT PROTECTED. PREPARED BY CENTRAL DRAWING OFFICE

DIMENSIONS : mm SCALE : 1 : 1
 TOLERANCE : LIN ± - ANG ± - ITEM NO : -
 MATERIAL : -
 VERSION INFO : TITLE REVISED.

Digitally signed by
 Ludwig Borchard
 Date: 2011.11.25
 08:35:57 +02'00'
 APPROVED

Digitally signed by
 Ludwig Borchard
 Date: 2011.11.25
 08:36:12 +02'00'
 AUTHORISED

PARALLEL CLAMP FOR
 VARIOUS CONDUCTOR SIZES.

TRANSNET
 freight rail
 CEE-TNB-0055
 AMENDMENT 5

Des: 10332996

ITEM	DESCRIPTION	QTY	STORES ITEM NO	DRG NO CEE-	AMENDMENTS		
1	CROSSHEAD	1		TNB-48	NO	NAME	DATE
2	BOW	1		TNB-47	1	JP du P	96-02-07
3	ROPE THIMBLE	1		TNB-39			

REVISED, DRG NO WAS CEE-TN-269.
DO REF: T96/003

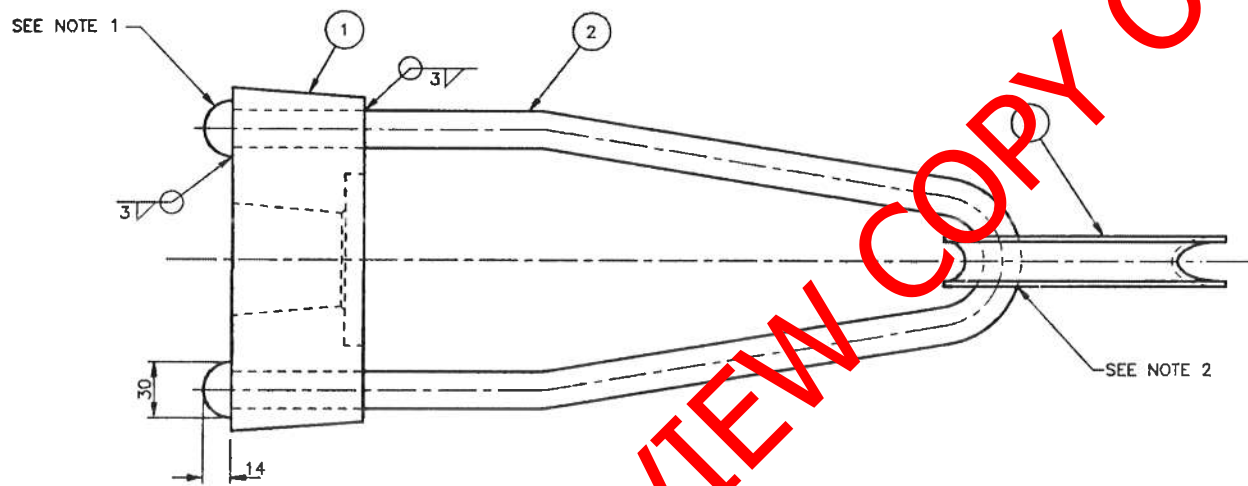

"PREVIEW COPY ONLY"

- NOTES
1. FORM RIVET HEADS "HOT".
 2. INSERT ITEM 2 THROUGH ITEM 3 BEFORE ASSEMBLY.
 3. STRENGTH: MINIMUM ULTIMATE TENSILE STRENGTH 222kN.
 4. ZINC COAT TO SABS 763 (TABLE 2) AFTER WELDING.

DO REF: C221/73	GEN TOL: LIN± 1	ANG± -
DRN: E G LOUW	CKD: J JACKSON	DATE: 74-02-06
ENG: _____	F PIENAAR	for CHIEF ENG
INFRASTRUCTURE (ELECTRICAL)		
SPOORNET		

BOW AND CROSSHEAD ASSEMBLY
STAY WIRE ARRANGEMENT

STORES ITEM NO 54/2437
DIMENSIONS: mm SCALE: 1:2
A2
DRAWING NO CEE- TNB-50
SHEET — OF —

T0000189