

TRANSNET



delivering freight reliably

REQUEST FOR QUOTATION (RFQ)
[RFQ NUMBER : PTH / 52320]

Request for Quote for the Provision/Supply : INSTALLATION OF 6 NEW INVERTER SPLIT AIR CONDITIONING UNITS AT ROSMEAD'S NEW OPERATIONS OFFICE (OLD WAITING ROOMS) 02AA101E

Transnet Freight Rail , a division of Transnet (SOC) Ltd invites all interested parties to respond to the above-mentioned RFQ. The RFQ documents may be inspected and obtained on and after 21 May 2013, from TRANSNET FREIGHT RAIL, SECRETARIAT OF THE ACQUISITION COUNCIL (ADMIN SUPPORT) , SUPPLY CHAIN SERVICES at SUPPLY CHAIN SERVICES BUILDING, 1st FLOOR, ROOM 105, STOW ROAD , UITENHAGE, during office hours of 07:30 TO 12:45 AND 13:30 TO 16:30 weekdays.

A specimen copy of the RFP will be made available for viewing at www.transnet.net/Tenders/TC/Pages/default.aspx. However, these documents are solely for viewing purposes only.

For enquiries regarding collection (or to make arrangements to collect it at the tenderbriefing) of the RFQ, please contact Ronelle Blom on 041 994 2045 or ronelle.blom@transnet.net

Please note: These documents will be available at a NO CHARGE.

A compulsory RFQ briefing session will be held on 28 May 2013 at 11:00 AT ROSMEAD STATION. Details of the briefing session are contained in the RFQ documents.

This RFQ shall close punctually at 10:00 on 11-Jun-13 in the tender box located at : TRANSNET FREIGHT RAIL , SECRETARIAT OF THE ACQUISITION COUNCIL (ADMIN SUPPORT) , TRANSNET FREIGHT RAIL , SUPPLY CHAIN SERVICE BUILDING, TENDERBOX, 1st FLOOR (PASSAGE), STOW ROAD, UITENHAGE.
IF POSTED:
TRANSNET FREIGHT RAIL , SECRETARIAT OF THE ACQUISITION COUNCIL (ADMIN SUPPORT), P.O.BOX 95, UITENHAGE.

Preference will be given to Respondents based on their B-BBEE status.

Transnet urges Clients, Suppliers and Service Providers to report any acts of fraud and/or instances of corruption to Transnet's TIP-OFFS ANONYMOUS on 0800 003 056 or TIP-off@tip-offs.com.

freight rail rail engineering pipelines port terminals national ports authority

SCHEDULE OF DOCUMENTS

SECTION 1	: Notice to bidders	(Page 2-9)
SECTION 2	: Quotation form (Rates page 11)	(Page 10-11)
SECTION 3	: Vendor application form	(Page 12)
SECTION 4	: General conditions	(Page 13- 17)
SECTION 5	: Project specifications	(Page 19
SECTION 6	: Attendance Certificate	(Page 20)
SECTION 7	: Refer to attachments	(Page 21)

NB All pages to be completed up to and include page 21

All pages Respondent's signature bottom left and firms date and company stamp on bottom right

“PREVIEW COPY ONLY”

TRANSNET



SOC LIMITED
(REGISTRATION NO.1990/000900/30)
Trading as

Transnet freight rail

RFQ (Request for quote) PTH 52320

INSTALLATION OF 6 NEW INVERTER SPLIT AIR CONDITIONING UNITS AT
ROSMEAD'S NEW OPERATIONS OFFICE (OLD WAITING ROOMS) 02AA101E ,

SITE MEETING : 28 May 2013

TIME : 11:00 AT ROSMEAD STATION

CLOSING DATE / TIME: 11-Jun-13 @ 10:00

TENDER BOX:

Transnet freight rail

Secretariat of the Acquisition Council (Admin support)

Transnet Freight Rail Building,

Tender Box (1st Floor, Passage)

Stow road,

Uitenhage.

COMMERCIAL (SCS): Dixie Diedericks 041 994 2033 Fax 041 994 2024

Up to the closing date : e' mail : dixie.diedericks@transnet.net

After closing date : Ronelle Blom 041 994 2045

: e' mail: ronelle.blom@transnet.net

FRAUD HOTLINE : TEL 0800 003 056

REAL ESTATE REF : PEA 6822 : PURCHASE REQUISITION :
PEDB:



TRANSNET FREIGHT RAIL a division of

TRANSNET SOC LTD

Registration Number 1990/000900/30

[hereinafter referred to as **Transnet**]

REQUEST FOR QUOTATION [RFQ] PTH 52320

FOR THE

**: INSTALLATION OF 6 NEW INVERTER SPLIT AIR CONDITIONING
UNITS AT ROSMEAD'S NEW OPERATIONS OFFICE (OLD
WAITING ROOMS) 02AA101E**

ISSUE DATE : 21 May 2013

TENDER BRIEFING: 28 May 2013

TENDER BRIEFING AND SITE MEETING COMPULSORY

TIME/PLACE : 11:00 AT ROSMEAD STATION

CLOSING DATE : 11-Jun-13

CLOSING TIME : 10:00

PREVIEW COPY ONLY

Section 1
NOTICE TO BIDDERS

Quotations which must be completed as indicated in Section 2 of this RFQ are to be submitted as follows:

Quotations must be in a sealed envelope with the following details : RFQ number : Closing date

CLOSING DATE : 11-Jun-13 @ 10:00

METHOD : Post or courier

**CLOSING VENUE : Transnet Freight Rail, SCS , Tenderbox, SCS Building, Stow road, Uitenhage
: Transnet Freight Rail, ASO, P.O.Box 95, Uitenhage, 6229**

NB. IF MINUTES OF THE TENDERBRIEFING THAT WAS HELD IS NOT RECEIVED WITHIN 48 WORKING HOURS YOU MUST CONTACT DIXIE DIEDERICKS TEL 041 994 2033 AND SEND HIM A MAIL (dixie.diedericks@transnet.co.za) WITH YOUR DETAILS. THIS IS TO ENSURE THAT ALL THE FIRMS THAT ATTENDED THE TENDERBRIEFING HAVE THE SAME INFORMATION.

1 Responses to RFQ

Responses to this RFQ [Quotations] must not include documents or reference relating to any other quotation or proposal. Any additional conditions must be embodied in an accompanying letter.

2 Broad-Based Black Economic Empowerment [B-BBEE]

Transnet fully endorses and supports the Government's Broad-Based Black Economic Empowerment Programme and it would therefore prefer to do business with local business enterprises who share these same values. Transnet will accordingly allow a "preference" to companies who provide a valid B-BBEE Verification Certificate. All procurement transactions will be evaluated accordingly.

o **B-BBEE Scorecard and Rating**

As prescribed in terms of the Preferential Procurement Policy Framework Act (PPPPA), Act 5 of 2000 and its Regulations, Respondents are to note the following:

- Proposals will be evaluated on price which will be allocated 80 points and preference which will be allocated 20 points, dependent on the value of the Services.
- The 80/20 preference point system applies where the acquisition of the Services will be less than R1 000 000.00.
- If the 80/20 preference point system is stipulated and all Bids received exceed R1 000 000.00, the RFQ will be cancelled.
- In this RFQ, Transnet will apply **80/20** preference point system prescribed in the PPPFA.

In compliance with the Government Gazette No 34612, Notice No. 754 dated 23 September 2011, as from 1 October 2011 valid B-BBEE Verification Certificates must be issued by:

- (i) Verification Agencies accredited by the South African National Accreditation System [SANAS]; or

- (ii) Registered Auditors approved by the Independent Regulatory Board of Auditors [IRBA], in accordance with the approval granted by the Department of Trade and Industry.

Enterprises will be rated by such agencies based on the following:

- a) **Large Enterprises** [i.e. annual turnover greater than R35 million]:
- Rating level based on all seven elements of the B-BBEE scorecard
- b) **Qualifying Small Enterprises – QSE** [i.e. annual turnover between R5 million and R35 million]:
- Rating based on any four of the elements of the B-BBEE scorecard
- c) **Exempted Micro Enterprises – EME** [i.e. annual turnover less than R5 million]:

In accordance with B-BBEE Codes of Good Practice [Statement 000, Section 4], any enterprise with an annual total revenue of R 5 million or less qualifies as an EME.

- Automatic rating of B-BBEE Level 4 irrespective of race or ownership
- Black ownership greater than 50% or Black Women ownership greater than 50% automatically qualify as B-BBEE Level 3

Sufficient evidence to qualify as an EME would be a certificate (which may be in the form of a letter) from an auditor or accounting officer or a certificate from a Verification Agency accredited by SANAS. The certificate must confirm the company's turnover, black ownership / black female ownership, B-BBEE status level and validity date.

Respondents are required to furnish proof of the above to Transnet. [i.e. a valid detailed scorecard as stipulated above in respect of Large Enterprises and QSEs, or a valid certificate in respect of EMEs].

Transnet will accordingly allocate a maximum of **20 [twenty] points** in accordance with the **80/20** preference point system prescribed in the Preferential Procurement Policy Framework Act (PPPFA), Act 5 of 2000 and its Regulations to the Respondent's final score based on an entity's B-BBEE scorecard rating. *[Refer **Annexure A – B-BBEE Preference Points Claim Form** for further details].*

N.B. Failure to submit a B-BBEE certificate, which is valid as at the Closing Date of this RFP, will result in a score of zero being allocated for B-BBEE.

[Refer clause 19 below for Returnable Documents required]

3 Communication

- a) Respondents are warned that a response will be liable for disqualification should any attempt be made by a Respondent either directly or indirectly to canvass any officer(s) or employee of Transnet in respect of this RFQ between the closing date and the date of the award of the business.
- b) A Respondent may, however, before the closing date and time, direct any written enquiries relating to the RFQ to the following Transnet employee:

Name: Dixie Diedericks

Email: Dixie.diedericks@transnet.net Tel : 041 994 2033

- c) Respondents may also, at any time after the closing date of the RFQ, communicate with Ronelle Blom on any matter relating to its RFQ response:

Telephone :041 994 2045

Email : ronelle.blom@transnet.net

4 Tax Clearance

The Respondent's original valid Tax Clearance Certificate must accompany the Quotation. Failure to provide this document with the RFQ submission may result in disqualification.

5 VAT Registration

The valid VAT registration number must be stated here: _____ *[if applicable]*.

6 Legal Compliance

The successful Respondent shall be in full and complete compliance with any and all applicable national and local laws and regulations.

7 Changes to Quotations

Changes by the Respondent to its submission will not be considered after the closing date and time.

8 Pricing

All prices must be quoted in South African Rand on a fixed price basis, excluding VAT.

9 Prices Subject to Confirmation

Prices quoted which are subject to confirmation will not be considered.

10 Negotiations

Transnet reserves the right to undertake post-tender negotiations with selected Respondents or any number of short-listed Respondents.

11 Binding Offer

Any Quotation furnished pursuant to this Request shall be deemed to be an offer. Any exceptions to this statement must be clearly and specifically indicated.

12 Disclaimers

Transnet is not committed to any course of action as a result of its issuance of this RFQ and/or its receipt of a Quotation in response to it. Please note that Transnet reserves the right to:

- modify the RFQ's goods / service(s) and request Respondents to re-bid on any changes;
- reject any Quotation which does not conform to instructions and specifications which are detailed herein;
- disqualify Quotations submitted after the stated submission deadline;
- not necessarily accept the lowest priced Quotation;
- reject all Quotations, if it so decides;
- place an order in connection with this Quotation at any time after the RFQ's closing date;

Respondent's Signature

Date & Company Stamp

- award only a portion of the proposed goods / service/s which are reflected in the scope of this RFQ;
- split the award of the order/s between more than one Supplier/Service Provider; or
- make no award at all.

In addition, Transnet reserves the right to exclude any Respondent from the bidding process who has been convicted of a serious breach of law during the preceding 5 [five] years, including but not limited to breaches of the Competition Act 89 of 1998. Respondents are required to indicate below whether or not they have been found guilty of a serious breach of law during the past 5 [five] years:

I/We _____ do hereby certify that I/we **have/have not been** found guilty during the preceding 5 [five] years of a serious breach of law, including but not limited to a breach of the Competition Act, 89 of 1998, by a court of law, tribunal or other administrative body. The type of breach that the Respondent is required to disclose excludes relatively minor offences or misdemeanours, e.g. traffic offences.

Where found guilty of such a serious breach, please disclose:

NATURE OF BREACH: _____

DATE OF BREACH: _____

Furthermore, I/we acknowledge that Transnet SOC Ltd reserves the right to exclude any Respondent from the bidding process, should that person or entity have been found guilty of a serious breach of law, tribunal or regulatory obligation.

13 Respondent's Samples

Not Applicable

14 Evaluation Criteria

Transnet will utilise the following criteria [not necessarily in this order] in choosing a Supplier/Service Provider, if so required:

- Administrative responsiveness - Completeness of response and returnable documents
- Substantive responsiveness – Prequalification criteria, if any, must be met and whether the Bid materially complies with the scope and/or specification given
- Weighted evaluation based on 80/20 preference point system as indicated in paragraph 2 above:
 - Pricing and price basis [firm] - whilst not the sole factor for consideration, competitive pricing and overall level of unconditional discounts¹ will be critical

- B-BBEE status of company

¹ Only unconditional discounts will be taken into account during evaluation. A discount which has been offered conditionally will, despite not being taken into account for evaluation purposes, be implemented when payment is effected.

Preference points will be awarded to a bidder for attaining the B-BBEE status level of contribution in accordance with the table below:

B-BBEE Status Level of Contributor	Number of points (80/20 system)
1	20
2	18
3	16
4	12
5	8
6	6
7	4
8	2
Non-compliant contributor	0

15 Validity Period

Transnet desires a validity period of 90 (Ninety days) from the closing date of this RFQ. This RFQ is valid until _____.

16 Banking Details

BANK: _____
 BRANCH NAME / CODE: _____
 ACCOUNT HOLDER: _____
 ACCOUNT NUMBER: _____

17 Company Registration

Registration number of company / C.C. _____
 Registered name of company / C.C. _____

18 Disclosure of Prices Quoted

Respondents must indicate here whether Transnet may disclose their quoted prices and conditions to other Respondents:

YES NO

19 Returnable Documents

Returnable Documents means all the documents, Sections and Annexures, as listed in the tables below.

a) Respondents are required to submit with their Quotations the Returnable Documents, as detailed below.

Failure to provide all these Returnable Documents at the Closing Date and time of this RFQ may result in a Respondent's disqualification. Respondents are therefore urged to ensure that all these Documents are returned with their Quotations. IF REQUESTED DOCUMENTS MUST BE SUBMITTED WITHIN 3 WORKING DAYS

 Respondent's Signature

 Date & Company Stamp

All Sections, as indicated in the footer of each page, must be signed, stamped and dated by the Respondent. Please confirm submission of these mandatory Returnable Documents by so indicating [Yes or No] in the table below:

"PREVIEW COPY ONLY"

.....
Respondent's Signature

.....
Date & Company Stamp

	Submitted [Yes or No]
SECTION 1 : Notice to Bidders	
<ul style="list-style-type: none"> - Valid B-BBEE Verification Certificate [RSA Large Enterprises and QSEs] Note: failure to provide a valid B-BBEE Verification Certificate at the closing date and time of the tender will result in an automatic score of zero being allocated for B-BBEE scorecard 	
<ul style="list-style-type: none"> - Valid B-BBEE certificate from auditor, accounting officer or SANAS accredited Verification Agency [RSA EMEs] Note: failure to provide a valid B-BBEE Verification Certificate at the closing date and time of the tender will result in an automatic score of zero being allocated for B-BBEE scorecard 	
<ul style="list-style-type: none"> - Letter of Good standing from Department of Labour 	
-	
<ul style="list-style-type: none"> - In the case of Joint Ventures, a copy of the Joint Venture Agreement or written confirmation of the intention to enter into a Joint Venture Agreement 	
SECTION 2 : Quotation Form	
SECTION 3: Vendor Application Form	
<ul style="list-style-type: none"> • Original cancelled cheque or bank verification of banking details 	
<ul style="list-style-type: none"> • Certified copies of IDs of shareholder/directors/members [as applicable] 	
<ul style="list-style-type: none"> • Certified copy of Certificate of Incorporation [CM29/CM9 name change] 	
<ul style="list-style-type: none"> • Certified copy of share certificates [CK1/CK2 if C.C.] 	
<ul style="list-style-type: none"> • Entity's letterhead 	
<ul style="list-style-type: none"> • Certified copy of VAT Registration Certificate [RSA entities only] 	
<ul style="list-style-type: none"> • Certified copy of valid Company Registration Certificate [if applicable] 	
<ul style="list-style-type: none"> • Original valid Tax Clearance Certificate [Consortia / Joint Ventures / Sub-contractors must submit a separate Tax Clearance Certificate for each party] 	
ANNEXURE A – B-BBEE Preference Points Claim Form	

Respondent's Signature

Date & Company Stamp

Respondents to complete this section:

COMPANY TRADING NAME _____

COMPANY REGISTERED NAME _____

COMPANY REGISTRATION NUMBER _____

NAME OF RESPONDENT

PHYSICAL ADDRESS

.....

Respondent's contact person:

Name.....

Designation.....

Telephone.....

Cell Phone.....

Facsimile.....

Email.....

.....

Service provider for Legal notices _____

.....

Fax number: _____

Attention _____

PREVIEW COPY ONLY

Respondent's Signature

Date & Company Stamp

Section 2 QUOTATION FORM

I/We _____
hereby offer to supply the goods/services at the prices quoted in the Price Schedule below, in accordance with the conditions related thereto.

I/We agree to be bound by those terms and conditions in:

- the Standard Terms and Conditions for the Supply of Goods or Services to Transnet [available on request]; and
- any other standard or special conditions mentioned and/or embodied in this Request for Quotation.

I/We accept that unless Transnet should otherwise decide and so inform me/us, this Quotation [and, if any, its covering letter and any subsequent exchange of correspondence], together with Transnet's acceptance thereof shall constitute a binding contract between Transnet and me/us.

I/We further agree that if, after I/we have been notified of the acceptance of my/our Quotation, I/we fail to deliver the said goods/service/s within the delivery lead-time quoted, Transnet may, without prejudice to any other legal remedy which it may have, cancel the order and recover from me/us any expenses incurred by Transnet in calling for Quotations afresh and/or having to accept any less favourable offer.

PREVIEW COPY ONLY

Respondent's Signature

Date & Company Stamp

I/We quote as follows for the goods required, on a "delivered nominated destination" basis, excluding VAT:]

TRANSNET SOC LIMITED

(REGISTRATION NO.19 90/000900/06)

trading as TRANSNET FREIGHT RAIL
(hereinafter referred to as TRANSNET FREIGHT RAIL)

RFQ. No: **PTH 52320**

INSTALLATION OF 6 NEW INVERTER SPLIT AIR CONDITIONING UNITS AT ROSMEAD'S NEW OPERATIONS OFFICE (OLD WAITING ROOMS) 02AA101E

Quote Form

I, We _____
_____ carrying on as business under the style and title of _____

hereby offer to undertake and complete the abovementioned work at a tender price and in accordance with the terms set in this Request for Quote , General and/or Special Conditions and Project Specifications for the sum of :

R _____ (in words) _____

_____ **(Exclusive of VAT)**
_____ **(Work days)**

Time to complete the work:

I/We undertake to complete the work for the duration of the contract as specified in the special conditions and particular specifications from the date of notification of the acceptance of my/our tender.

N.B. (i) In the event of any discrepancy, the amount in words will take precedence over the amount in figures.

(ii) **NOTE: The price as transferred to this form shall be the tendered price, any error in pricing in this schedule, even an arithmetic error will have to be adjusted to comply with the tendered price as given on this page**

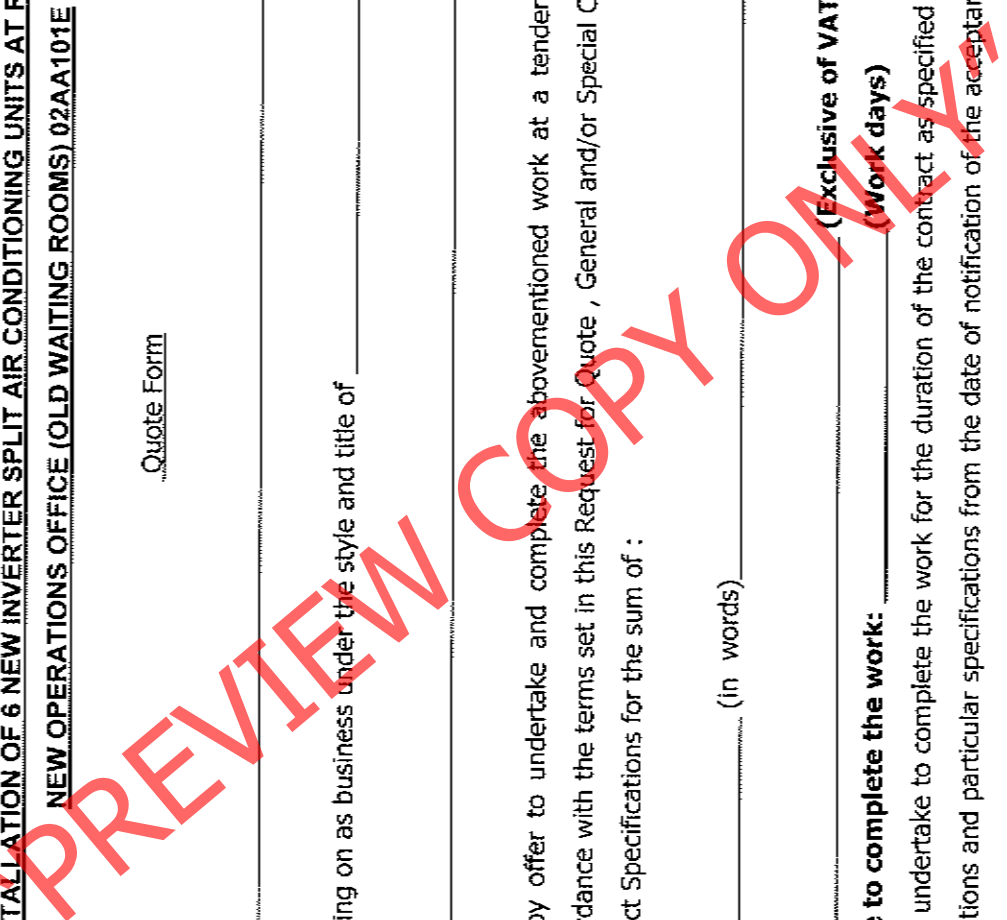

Notes to Pricing:

- a) All Prices must be quoted in South African Rand, exclusive of VAT
- b) To facilitate like-for-like comparison bidders must submit pricing strictly in accordance with this price schedule and not utilise a different format. Deviation from this pricing schedule could result in a bid being disqualified.
- c) Please note that should you have offered a discounted price(s), Transnet will only consider such price discount(s) in the final evaluation stage if offered on an unconditional basis.

"PREVIEW COPY ONLY"

Section 3
VENDOR APPLICATION FORM

ANNEXURE A

ONLY TO BE COMPLETED IF REQUESTED

**ALL THE DOCUMENTS MUST BE COMPLETED AND AVAILABLE WITHIN 3 WORKING DAYS
OR YOUR QUOTE WILL BE REREJECTED**

PREVIEW COPY ONLY

.....
Respondent's Signature

.....
Date & Company Stamp

Section 4

General Conditions and Specification

1. Scope of work

INSTALLATION OF 6 NEW INVERTER SPLIT AIR CONDITIONING UNITS AT ROSMEAD'S NEW OPERATIONS OFFICE (OLD WAITING ROOMS) 02AA101E

2. Site location

The site is situated at per specification

3. Time to complete the work

The tenderer shall indicate at section 2 the time he will require to complete the work, however, this time should not exceed time as per specification. This period shall be exclusive of weekends, public holidays and statutory holiday periods.

Falling completion of the work within the period as stipulated above or with any shorter period offered by the tenderers and accepted by Transnet, the contractor shall pay to Transnet the sum of as per specification for every day or part thereof during which the works remain incomplete.

4. Guarantee

All workmanship and material shall be guaranteed for a period as indicated in specification of completion of work.

5. Inspection of works

5.1 No work shall be covered up or put out of view without the approval of the Project Manager. The Contractor shall afford full opportunity for the Project Manager to examine and measure any work, which is about to be covered up or put out of view and to examine foundations before permanent work is placed thereon.

5.2 The Contractor shall give due notice to the Project Manager whenever any such work of formations is or are ready or about to be ready for examination. The Project Manager shall, without unreasonable delay, unless he considers it necessary and advises the Contractor accordingly, examine and or measuring such work as required.

5.3 The Contractor shall uncover any part or parts of the work or make openings in or through the same as the Project Manager may from time to time direct and shall reinstate and make good such part or parts to the satisfaction of the Project Manager and are found to be executed in accordance with the Contract, the expenses of uncovering, making openings in or through, reinstating and making good the same shall be done by the Contractor .

Site records

6.1 Site Instruction Book

The Contractor shall provide a **site instruction book (not smaller than A5) , in triplicate for the Project Manager to place all instructions** that are needed to compliment the specifications and drawings and any other instruction that may affect the cost of the work.

No work will be recognized for additional payment unless it has been recorded and signed by the Project Manager in the aforesaid book.

6.2 Site Diary

The contractor shall provide a diary, in triplicate to record all day to day incidents that could occur during the contract period. This includes weather, names & numbers of workers on site, material that has been delivered, material that has been loaded and disposed off, incidents that have occurred, nature of work to be done on that day, etc.

6.3. Programming & Planning of the work

The contractor shall provide to the Project Manager a detail plan of how he intends to do the work and this plan must be to the requirements of the operation of Transnet Freight Rail workshop with minor disruptions as no delays must be allowed in this regard.

The program must be agreed to (in the site instruction book) before any work will be allowed to commence on the workshops, per se. The programme can be in a form of a pert (bar) chart and will be used as a guide to measure progress of the work.

7. Water supply.

Water may be made available for the purpose of construction of the works only. The water shall be used conservatively and if not, this privilege shall be removed and the water shall be metered, and the cost of the metered water shall be borne by the Contractor as well as all charges as entertained by Transnet Freight Rail. The Contractor must supply all drums, connections, hoses, clamps etc., as necessary and to provide water to the working site.

8. Electricity supply.

Electricity may be made available to the Contractor. The contractor must adhere to the safety standards as per the General Safety Regulations, Electrical Machine Regulations, Electrical Installation Regulations of the **Health and Safety Act, (Act 85 of 1993)** and SANS 10142.

The Contractor must supply all leads and plugs as necessary and to provide power to the working site

9. Access to site

The areas are restricted and the contractor must ensure he complies with the regulations of Transnet Freight Rail in every way. The Contractor and/or any sub-contractors shall be required to apply for permission to enter the restricted area in writing. A list of workmen shall be given to the Project Manager to arrange for the necessary permits. 48 Hours minimum notice is necessary for the processing these permits. This includes changes to staff during the contract period.

10. Materials found on site

No material that is lying on the site (other than that as specified in this document) or any Transnet Freight Rail's properties may be removed or used (even if deemed as scrap) by the contractor.

11. Cleaning of site

The Contractor shall provide for cleaning up and sorting all rubbish and debris of whatever kind, generated by this work only, throughout the duration of the contract. Upon completion the Contractor shall clear away and remove all rubbish, unused material, plant and debris caused by the works and leave the site and the whole of the works clean and tidy to the satisfaction of the Project Manager.

12. Working outside normal working hours

The normal working hours are between 07:30 and 16:00 Mondays to Fridays. If it is required to work outside the stated normal working hours the Contractor must obtain written permission at least 24 hours before such work needs to be undertaken. Transnet Freight Rail will not unreasonably withhold permission, however the Contractor may have to pay for Transnet Freight Rail's supervisory personnel.

13. Escalation

This contract does not make provision for compensation in respect of increased costs. The contenders must allow in his fixed price for any increased costs, which he may encounter during the contract period or such extended period as agreed upon by both parties.

14. Retention

Transnet Freight Rail reserves the right to retain up to ten (10) percent of the value of the contract, for a period of six months (the maintenance period) or such further period beyond the maintenance period if defects have not yet been made good to the satisfaction of the Project Manager.

15. Safety Precautions and Insurance

15.1. Act 85

The contractor shall comply with the Occupational Health & Safety Act, 1993 (Act 85 of 1993). The form E.4E as placed in this Specification must be adhered to. (**Available on request**) But will be completed by the successful tenderer.

15.11 E7/1

Specification for works on, over, under adjacent to Railway lines and near high voltage equipment. (Available at the tenderbriefing)

15.2 Environment

The Contractor shall, at all times, comply with the statutes that prohibit pollution of any kind. These statutes are enacted in the following legislation.

- The National Environmental Management Act, 107/1998;
- The Environmental Conservation Act, 73/1989; and
- The National Water Act, 36/1998.

The Contractor shall appoint a responsible person to ensure that no incident shall occur on site that could cause pollution. Where the Contractor was negligent and caused any form of pollution the damage shall be rectified at the Contractors cost.

15.3 SUBSTANCE ABUSE TESTING

The OHSA (Act 85 of 1993) clearly states in the Safety Regulations 2A

"INTOXICATION" An employer or user, as the case may be, shall not permit any person who appears to be under the influence of intoxicating liquor or drugs, to enter or remain at a workplace. Transnet Freight Rail enforces this legislation by means of its Substance Abuse Policy, and therefore reserves the right to do substance abuse testing on anyone who enters their premises.

16. Health and Safety Requirements:

As per the E4E (Health and Safety requirements) no work can commence before the certificate of Good Standing by the Compensation Commissioner, or proof of payment, has been delivered to this office, for this project.

17. Note:

17.1 For further descriptions of materials to be used and methods to be adopted, the Contractor is referred to the various Codes and Standards, where relevant, and this shall be deemed to form part of the descriptions of any items in the following Specification. Except where any specification provision in a description in this specification is at variance with the above, in which case the specific provision is this Specification description shall apply.

17.2 Where trade names and catalogue references have been used in these Specifications to specify a product, Tenderers must tender on that particular or similar product. In addition, Tenderers must tender on the design specified. The accepted tenderer (i.e. Contractor) may, after obtaining written authority from the Project Manager, use an alternative product or design.

17.3 Where such written authority is given by the Project Manager at the request of the Contractor, for the contractor's convenience, all additional costs involved will be done for the Contractor's account. In the event of a less expensive product or design being used, a variation order reflecting the saving in cost will be issued.

18. GENERAL

18.1 Standard Specification

In so far as they can be applied and where they are not inconsistent with the terms of this specification, the following specifications shall be regarded as being embodied in this specification.

SANS Specifications (To be obtained by the contenders)

National Building Regulations	SANS 10400 – 11990
General Structural	SANS 11200AH- 11982
Electrical Code of Practice	SANS 10142

18.2 To be supplied by the Contractor

The Contractor shall provide all labour, transport, consumable stores, plant, equipment, tools, services, materials and ingredients of every description required for the carrying out and completion of the WORKS as per this specification and as may be ordered by the Manager.

18.3 Site meetings

The Contractor shall be called upon to attend meetings on the site to discuss the progress of WORKS with the Transnet Freight Rail representatives.

18.4 Setting out of the works

The setting out of the work shall be the sole responsibility of the Contractor and shall be done in accordance with this Specification, the drawings and the design.

18.5 Keep site tidy

The Contractor shall keep the site tidy at all times and remove all old material and such as rubble, off-cuts, demolished material, surplus material and carry away and dump or store onto or at an approved site.

A permit must be obtained from the Municipalities to transport material on their roads, when required.

19. Preliminary and General (P & G)

The P & G shall be as per General & Special Conditions and will include all costs not directly related to the execution of the work as stated. All items not specifically mentioned form part of P & G's

“PREVIEW COPY ONLY”

Section 5

Project Specifications

"PREVIEW COPY ONLY"

TRANSNET SOC LIMITED
(REGISTRATION NO 1990/000900/30)

trading as TRANSNET FREIGHT RAIL
(hereinafter referred to as TRANSNET)

RFQ : PTH 52320

INSTALLATION OF 6 NEW INVERTER SPLIT AIR CONDITIONING UNITS AT
ROSMEAD'S NEW OPERATIONS OFFICE (OLD WAITING ROOMS)
02AA101E

SECTION 1

1. GENERAL

1.1 Scope of work:

- 1) The installation of one (1) 18000 BTU split inverter type air conditioner.
- 2) The installation of five (5) 12000 BTU split inverter type air conditioners.
- 3) The electrical supply to all the above units.
- 4) The exact positions of split air conditioners to be determined on site.
- 5) Supply of COC for Air conditioner installation.

1.2

Standard Specification

In so far as they can be applied and where they are not inconsistent with the terms of this specification, the following specifications shall be regarded as being embodied in this specification.

1.2.1 SABS Specifications (To be obtained by the contenders)

The wiring of Premises
SANS 10142-1 (Old SABS 0142)
Occupational health and Safety Act Act 85 - 1993

1.3

To be supplied by the Contractor

The Contractor shall provide all labour, transport, consumable stores, plant, equipment, tools, services, materials and ingredients of every description required for the carrying out and completion of the WORKS as per this specification and as may be ordered by the Project Manager.

SECTION 2

Electrical Work

2 General:

The contractor shall ensure that the SANS 10142-1 Wiring of Premises is adhered to and that the relevant Health and Safety Act are met.

Electrical contractor to remove all left over material, rubble, and electrical equipment stripped by the contractor and is for his own property.

All material and equipment used to be S.A.B.S. approved and workmanship to be of a high quality and standard, done to the satisfaction of TRANSNET FREIGHT RAIL's site supervisor.

NB : The contractor is responsible for his own measurements where applicable, however, where rates are given the actual work done will be measured on completion and paid accordingly.

2.1 PROJECT SPECIFICATIONS

a) Air conditioners

The cooling capacity for the units shall be 1 x 18000 and 5 x 12000 BTU INVERTER SPLIT TYPE units.

The units shall be factory assembled and tested, supplied ready for operation, will be Samsung, LG or Mitsubishi.

The standard to which the units are rated must be stated.

The units shall be suitable for one of the following duties as per schedule of requirements: **Cooling and Heating, and will be possible to be operated via remote control.**

The unit shall be suitable to operate under the following conditions: - Ambient temperature minus 5°C to 45°C Relative humidity up to 86%

The units shall be suitable for operation from 220 / 230 Volt 50 Hz, single-phase electrical supply.

The controls will be of remote or manually controlled type.

Controls shall at least incorporate the following elements:

On/Off switch

Cooling/heating thermostat

Damper control to regulate entry of fresh air.

Tenderers shall state the make and capacity of units offered and shall provide full details at the time of tendering.

The units shall be provided with some suitable means of draining excess condensate. A description of the moisture system shall be submitted.

The unit shall emit minimum noise at approx. **36Db at 3m.**

The compressor shall be sealed and be provided with vibration isolators.

All units must be sprayed with **Techtal** and be **Corium** treated.

Tenderers shall provide pamphlets describing the unit at the time of tendering.

Full information on the guarantee offered is to be provided.

Compressor.....years. Air conditioning unit.....years.

All walls or windows used for the installation to be made good after installation of units.

General Installation Instructions

Condensing Units

The condensing units shall be mounted on cantilever brackets {40 x 40 galvanised unistrut trunking P2000} on rubber footings and using 14mm² Rawl bolts to fasten the brackets.

Piping

The piping used for connecting the evaporator to the condensing unit will be soft drawn copper as per manufactures specification. All copper piping to be covered with close cell amoum-flex. These pipes will be neatly strapped together and terminated with black cable ties. These pipes will neatly run on the wall surface inside unistrut trunking (P2000) or similar trunking, fastened to the wall using 6 x 35mm nail in anchors.

Drain pipes

The drain pipes to be of UPVC 25mm² (blue pipe). Note that where intersection / joints are made to the drainpipes; it will be made with a standard joint (made to use with these pipes) and fastened with PVC weld. The outlet ends will be slightly bend away from the wall at about 30° so the excess water will not drip onto the walls of the building. In as far as practically possible the drain system of the air conditioners should be linked to that of the building. The pipes will be fastened to the wall making use of PVC or metal saddles with nail in anchors at not more than 1 meter intervals.

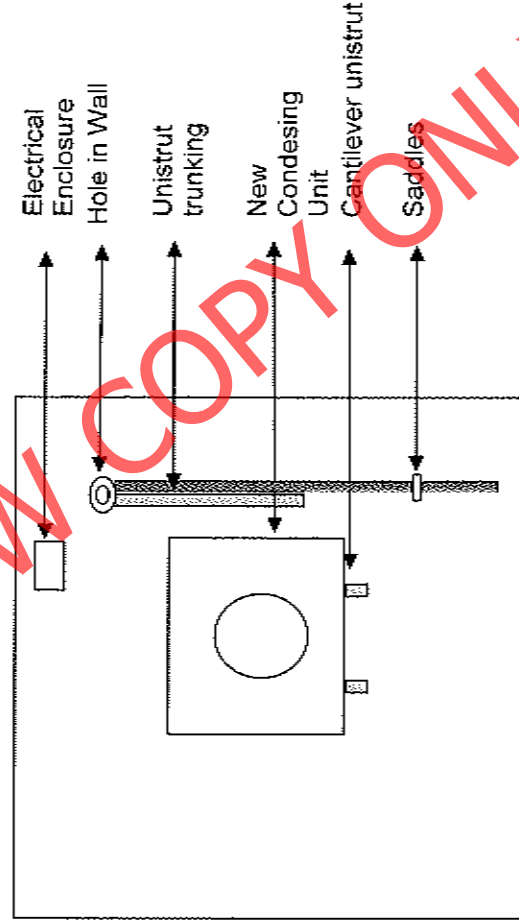

Electrical System

The supply must be via a 30Amp double pole isolator (switch disconnecter). These isolators will be situated in a **2 x 4 York Box** enclosure (for each split unit) and secured with nail in anchors using all holes provided. This must be situated in close proximity of the condensing units. The interconnecting cables used will be black surfex cable of the appropriate size as per manufactures specifications. Where the supply wires are running on exposed surfaces it will be laid in trunking of the appropriate size and be fastened using nail in anchors of not less than 6mm² x 35mm long at 500mm intervals.

Note that all electrical work must be carried out as per SANS 10142

2.2 To be supplied by the Contractor

The Contractor shall provide all labour, transport, consumable stores, plant, equipment, tools, services, materials and ingredients of every description required for the carrying out and completion of the Works as per this specification and any further work as may be ordered by the Engineer/Manager.

2.3 Site meetings

The Contractor shall be called upon to attend meetings on the site to discuss the progress of WORKS with the Project manager.

2.4 Recording of the works:

The Contractor shall keep and maintain accurate records in the site diary of all work so that any disputes can be resolved and that the extent of the required tests on the materials can readily be determined.

2.5 Setting out of the works:

The setting out of the work shall be the sole responsibility of the Contractor and shall be done in accordance with the "Guidelines for the provision of Engineering Services in Residential Townships" by The Department of Community Development.

2.6 Keep site tidy:

The Contractor shall keep the site tidy at all times and remove all old material and such as rubble, off-cuts, demolished material, surplus material and carry away and dump or store onto or at an approved site. If required, a permit must be obtained from the local Municipality to transport material on their roads.

2.7 Day work Rates:

The contractor shall be paid as per the tender rates and prices and any addition or omission shall be to the discretion of the Project manager all as per the site instruction book. When an item is not in the schedule then a variation shall be given based on day work rates and shall be recorded in the diary (day book) plus material with handling costs (percentage) all as per the preambles in the Schedule of Rates and Prices, herein.

THIS (SCHEDULE OF RATES AND PRICES) MUST BE FILLED IN AND ADDED TO THE TOTAL CONTRACT PRICE.

The profit required to do the work shall be to the contractor's consideration and must be allowed for in the entire Schedule of Rates and Prices.

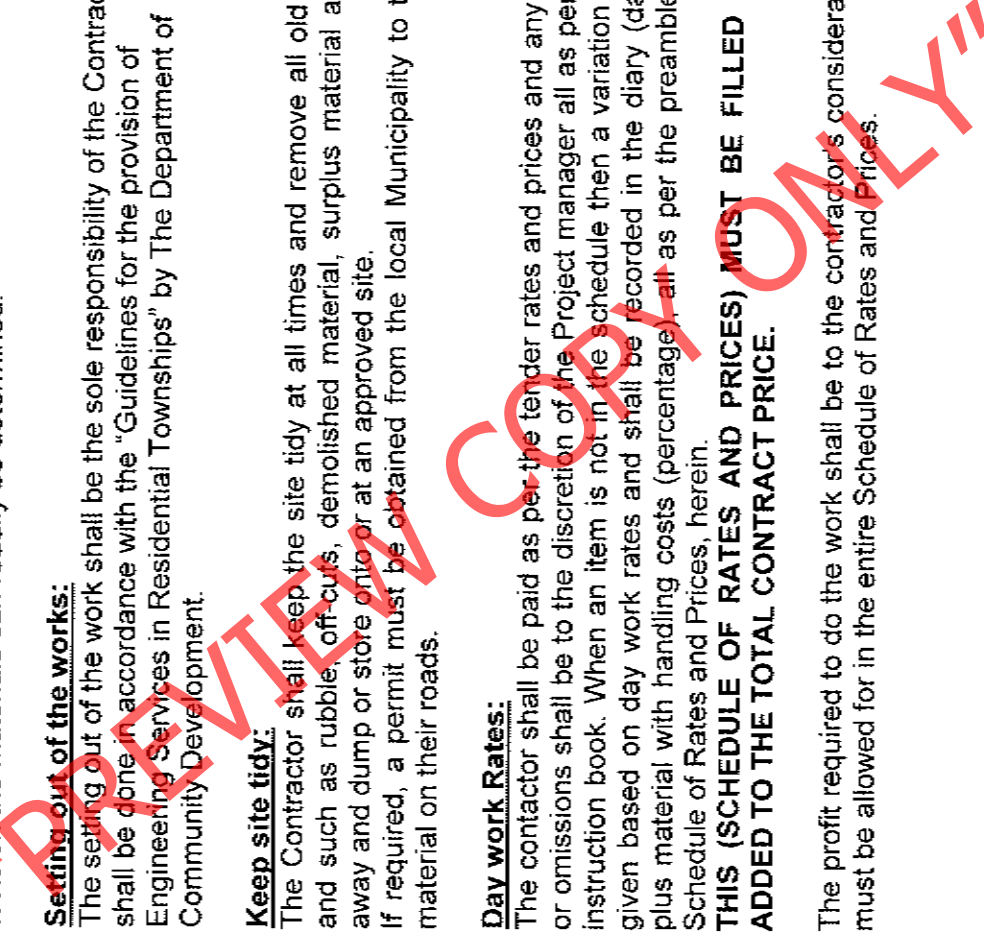

SECTION 3

3.1 Time To Complete The Work:

Time to complete the work will be **7 days (Seven days)**
Failing to complete the work as accepted, the contractor shall pay Transnet a sum of **R1000.00 (One Thousand Rand) per day**, or part thereof, for which the works remain incomplete.

3.2 Quality

Guarantee the quality of his workmanship for a period of twelve (12) months. In the event of Transnet in its sole discretion, being dissatisfied for whatever reason with any or all of the work performed by the Contractor, Transnet shall forthwith notify the Contractor thereof. The Contractor shall then forthwith redo the complete work at his own expense to the satisfaction of Transnet.

3.3 Traveling:

No traveling time is allowed for within the radius of 20km from the station. Therefore, the price is inclusive of traveling in this zone. If work is outside this zoning that the contractor shall be compensated for this via a rate. This shall be from the 20km radius to the requested work. This price is inclusive of return trip.
NOTE: rate is only for one way the return trip is not allowed for and must be included in the rate.

3.4 Incompetent Employees:

Any person employed by the contractor on the work who is, in the opinion of the Project Manager, incompetent, or who may act in such an improper manner, may be discharged from the work by the Project Manager and such a person shall not be employed on the work again without the permission of the Project Manager.

3.5 General:

- [a] All material to be SABS approved. Adhere to manufacturers specifications and instructions.
- [b] Where trade names are used it can be or similar and approved by project leader on site.
- [c] All dimensions and quantities to be checked on site by tenderer before commencing with the work.
- [d] All rubble and hazardous material to be dumped at an approved dumpsite.
- [e] Contractor to adhere to all safety regulations as per Occupational health and Safety Regulations Act, 85 of 1993.
- [f] Adhere to the safety rules and regulations of the Depot.
- [g] All contract workers will attend a safety induction course presented by Transnet Freight Rail
- [h] The Building will be occupied during renovations / repairs.

3.6 Risks Assessed

- [a] Working with scaffolding.
- [b] Working with step ladders.
- [c] Working with flammable liquid
- [d] Working with electric tools
- [e] Working on roofs

3.7 Safety.

- [a] The contractor must, on a regular basis, liaise with the Project Leader. The Project Leader and the Depot Manager must, on regular basis, be provided with an updated program.
- [b] At all times the safety aspect of the project must be treated as very important.

SECTION 4**General conditions**

- 4.1 It is the responsibility of the contractor to have sufficient means of communication for Transnet Freight Rail to be able to contact the contractor during normal working hours and after normal working hours. A fax machine must be available at all hours during normal working hours as well as after normal working hours for emergency correspondence.
- 4.2 A site access certificate will be issued to the contractor and must be displayed to any person on request.

REVIEW COPY ONLY

Section 6
NUMBER PTH52320

**INSTALLATION OF 6 NEW INVERTER SPLIT AIR CONDITIONING UNITS AT
ROSMEAD'S NEW OPERATIONS OFFICE (OLD WAITING ROOMS) 02AA101E**

CERTIFICATE OF ATTENDANCE OF SITE MEETING / BRIEFING SESSION

It is hereby certified that -

1.
2.

Representative(s) of
(name of company)

attended the site meeting / briefing session in respect of the proposed Service to be rendered in terms of this RFQ on 28 May 2013.

.....
TRANSNET'S REPRESENTATIVE
REPRESENTATIVE

.....
RESPONDENT'S

DATE: 28 May 2013

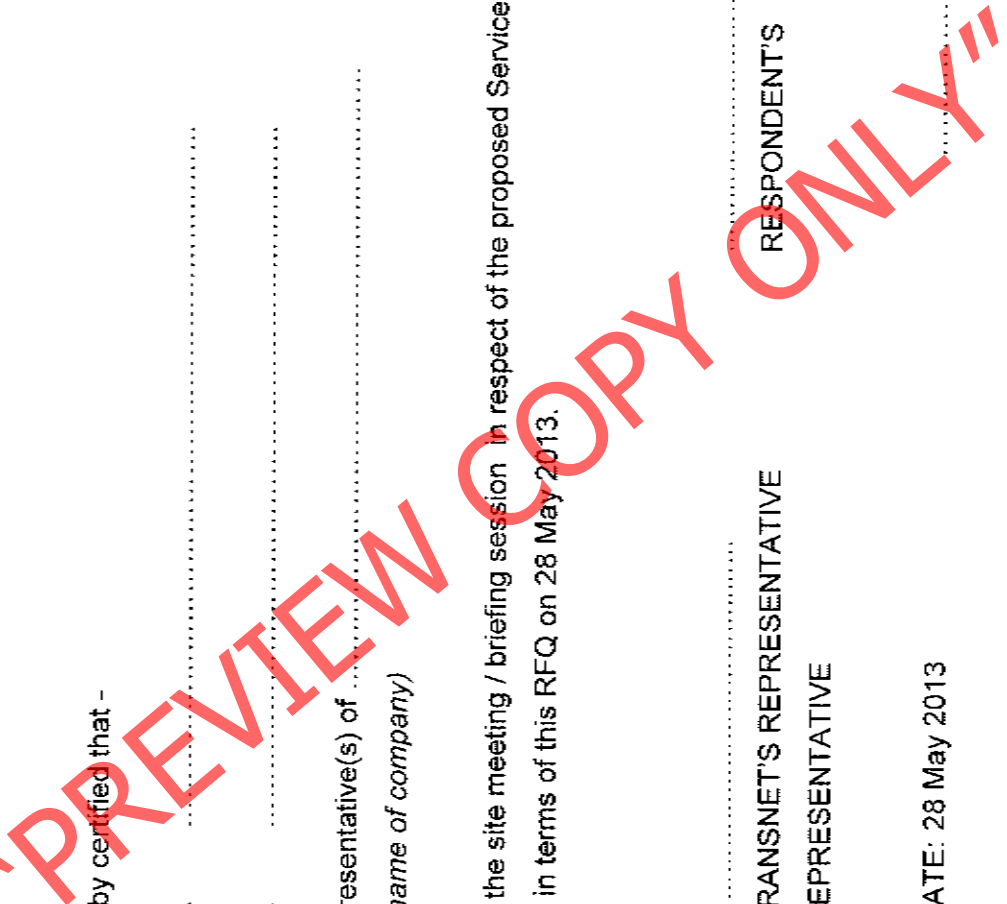

Section 7 (Attachments)

A) Vendor application form (Pages

(Must be completed and documents to submitted within 3 working days if requested) (3 pages)

B) E4E (Act 85) (Pages)

**SAFETY ARRANGEMENTS AND PROCEDURAL COMPLIANCE
WITH THE OCCUPATIONAL HEALTH AND SAFETY**

ACT; ACT 85 OF 1993 AND REGULATIONS (To be completed before work commence)

C: E/7/1 (Pages)

**SPECIFICATION FOR WORK ON, OVER, UNDER OR ADJACENT TO RAILWAY LINES AND
NEAR HIGH VOLTAGE EQUIPMENT (16 Pages)**

D) CSS 5

GENERAL TENDER CONDITIONS – SERVICE (10 pages)

E) SUPPLIER CODE OF CONDUCT (Pages 5)

(Including any complaints by Respondent)

By signing the RFQ documents, the Respondent is deemed to acknowledge that he / she has made himself / herself thoroughly familiar with all the conditions governing this RFQ, including those contained in any printed form stated to form part hereof and Transnet Limited will recognise no claim for relief based on an allegation that the Respondent overlooked any such condition or failed properly to take it into account for the purpose of calculating tendered prices or otherwise. (THIS INCLUDE ALL ATTACHMENTS A-E)

SIGNATURE OF RESPONDENT'S AUTHORISED REPRESENTATIVE:

.....
Respondent's Signature

.....
Date & Company Stamp